

F2524-MPT

f=25mm F2.4
for 1.4 Type 45 Megapixel cameras, Fixed-focal
C-Mount

Model No.		F2524-MPT		Effective	Front	φ 20.7mm	
Focal Length		25mm		Lens Aperture	Rear	φ 18.7mm	
Max. Aperture Ratio		1:2.4		Distortion (Inf.)	1.4 Type	0.06%	
Image Circle Diameter		φ 23.1mm		Back Focal Length		18.1mm	
Operation Range	Iris	F2.4 - F16.0		Flange Back Length		17.526mm	
	Focus	0.15m - Inf.		Mount		C-Mount	
Control	Iris	Manual		Filter Size		M34 P=0.5mm	
	Focus	Manual		Dimensions		φ 39mm × 66mm	
Operating Temperature		-10°C - +50°C		Weight		152g	
Angle of View	Sensor Size	1.4 Type		1.2 Type		1.1 Type	
	Diagonal	19.08mm × 13.03mm	49.6°	14.60mm × 12.63mm	42.4°	14.19mm × 10.38mm	39.0°
	Horizontal	(φ 23.1mm)	41.9°	(φ 19.3mm)	32.7°	(φ 17.6mm)	31.8°
	Vertical		29.3°		28.5°		23.6°

Dimensions

This information is brought to you by:



ELECTRONIC GROUP, INC

480-635-8400 p * aegis-g2@aegiselect.com

<http://www.aegis-elec.com>

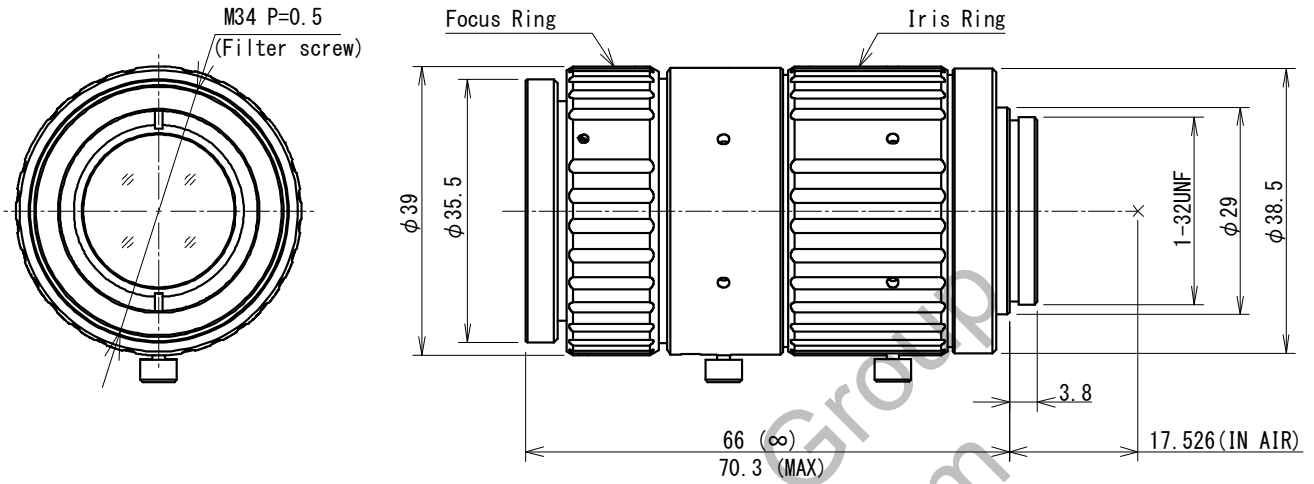

Aegis Electronic Group
www.aegiselect.com