

SRM-17S-DB-H

17" Sunlight Readable Monitor

- 1,000 nits Brightness Produces Clear, Sharp Images Even in Direct Bright Sunlight
- *TRU-Tuff* Ensures Maximum Shock & Vibration Resistance
- High Resolution: 1280 x 1024 (SXGA)
- Internal Rear Speaker
- Lockable On-Screen Display (OSD) Controls
- Dim-To-Black Function and Auto Re-Start After Power Loss
- Can Be Customized to Meet Your Needs - 3-Year Warranty



SUNLIGHT READABLE MONITORS

The SRM-17S-DB-H are 17" sunlight readable monitors. They feature at least 1000 nits brightness and a 4:3 aspect ratio. We design the SRM-17 Series monitors for use in direct sunlight. Consequently, they are also perfect for other high ambient-light conditions. They utilize state-of-the-art LED backlights. The models in this series produce at least 1,000 nits brightness. In contrast, this is over 3 to 5 times brighter than standard monitors. For example, standard monitors are only 200-300 nits brightness. Therefore, the result is amazingly bright screen. This will provide you with crystal-clear images, even with bright, direct sunlight on the face of the screen.

RUGGED INDUSTRIAL MONITORS

The SRM-17S-DB-H Sunlight Readable monitors are extremely rugged. For instance, we build them with true industrial-grade components. Furthermore, they receive our exclusive *TRU-Tuff* treatment. The *TRU-Tuff* process includes RTV silicone on all connections and critical components. Additionally, all wires are dressed, tie-wrapped and secured. Lastly, we apply ThreadLock to all screws. The ABS enclosure will ensure shock and vibration resistance for this rugged 1000 nit monitor.

HIGH BRIGHTNESS MONITOR WITH EXTREME OPERATING TEMPERATURES

We design the SRM-17S-DB-H 17" High Brightness Display Series to operate in nearly any environmental conditions. Whether in frigid conditions or blazing heat, these sunlight displays will survive and thrive. To clarify, these monitors will operate in temperatures down to -30°F (-35°C). They will also withstand brutal heat. Moreover, operating temperatures go up to 185°F (85°C). The rugged ABS enclosure assures these 17" high brightness displays will provide years of reliable imaging performance. Specifically, typical MTBF for these monitors is 50,000 hours.

HIGH BRIGHT MONITORS DEPLOYED WORLDWIDE

Our 17" sunlight readable monitors have been deployed in a wide range of demanding industries. For example, **military**, law enforcement, and entertainment benefit. They are also found in **inspection**, **oil and gas**, and **transportation**. Additionally, see how **pipeline**, **manufacturing** and **drone** industries also enjoy TRU-Vu displays. *TRU-Vu* monitors are backed by our full 3-Year Warranty. This ensures you of many years of reliable service.

In conclusion, see our full line-up of industrial-grade **Sunlight Readable** and **Daylight Readable**. This highlights all of our high brightness monitors. Additionally, you'll find the sunlight readable touch screens in all the sizes and configurations available. Browse similar sized monitors and filter by the features important to you. TRU-Vu can provide modified or **Custom OEM LCD Displays**. **Private Label Monitors** are also an option if you have very specific requirements. We are here to help. Feel free to give us a call so that our technical experts may assist you in finding the best display for your application.

SPECIFICATIONS

	SRM-17S-DB-H
LCD Panel	17" Color LCD; LED Backlights
Resolution	1280 x 1024 (SXGA)
Viewable Area	13.30" (W) x 10.64" (H) (337.9 x 270.3 mm)
Pixel Pitch	0.264mm
Display Colors	16.7 Million
Aspect Ratio	4:3 (5:4)
Brightness	1,000 nits
Contrast Ratio	1,000:1
Dim-To-Black	Standard
Viewing Angle	160° (H) x 140° (V)
Response	5 msec Trf
Control	OSD (On-Screen Display) via Front Panel Pushbuttons
Video Inputs	VGA, S-Video, Composite (BNC) NTSC/PAL
Audio	Rear Speakers
Power Requirement	12 VDC (2.1mm Barrel Plug); 90-240 VAC via Included Power Brick
Power Consumption	50 Watts
Enclosure	ABS
Mounting	75x75mm Rear VESA Hole Pattern (Optional Tabletop Base)
Operating Temperature	-30° to +185°F (-35° to +85°C)
Humidity	5-90% RH
Shock	50 G (20 msec, ½ sine)
Vibration	1.5G RMS 10-200 HZ
Dimensions	14.88 (W) x 12.50" (H) x 1.91" (D) (378 x 317.5 x 48.6mm)
Weight	5.78 lbs. (2.62 kg)
Warranty	3 Years

Note: Specifications subject to change without notice.

DIMENSIONS (MM)

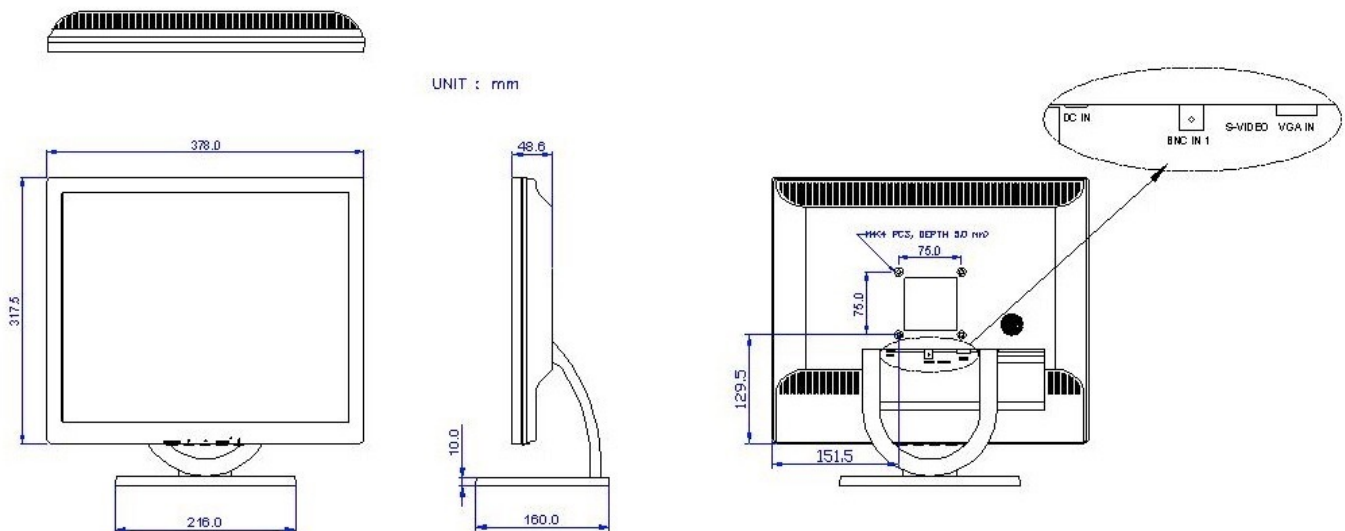

Standard Accessories:

- 90-240 VAC Power Supply
- VGA Cable
- Audio Cable (3.5mm Headphone Jack to RCA)

Available Options:

- HDMI Input
- DisplayPort Input
- Tabletop Base
- Automated Ambient Light Sensor
- Protective/Anti-Glare Glass
- Waterproof NEMA 4 Enclosure (VMW-17C-SS)
- BNC Loop-Thru Video Input
- 24 VDC Operation
- Optical Bonding (SRMOB-17)
- Rack Mount Bracket MB-Rack-17
- Touch Screen (VMT-17 Series)
- Open-Frame Configuration
- Private Label
- Other Customer - Specific Modifications