

This information is brought to you by:



## 5 Megapixel IR E3Z4518CS-MPIR

**3X 4.5mm-13.2mm F1.8**

**for 1/1.8" type Megapixel Day&Night Camera, Varifocal Manual Iris  
CS-Mount**



Model No.	E3Z4518CS-MPIR		Effective	Front	φ25.1mm		
Focal Length	4.5mm - 13.2mm		Lens Aperture	Rear	φ10.0mm		
Max. Aperture Ratio	1 : 1.8		Back Focal Length	18.83mm - 8.78mm			
Max. Image Format	6.4mm x 4.8mm (φ 8mm)		Flange Back Length	12.5mm			
Operation Range	Iris	F1.8 - F16C		Mount	CS-Mount		
	Focus	0.5m - Inf.		Filter Size			
	Zoom	4.5mm - 13.2mm					
Control	Iris	Manual		Dimensions	φ42mm x 61mm		
	Focus	Manual		Weight	148g		
	Zoom	Manual					
Angle of View	D	1/1.8 type (16:9)	112.8° - 40.1°	1/1.8 type (4:3)	112.8° - 40.1°	1/2 type (4:3)	100.3° - 35.7°
	H		105.3° - 35.3°		100.1° - 32.6°		80° - 28.6°
	V		72.3° - 20.3°		83.9° - 24.8°		59.8° - 21.5°
Operating Temperature	-10°C - +50°C						

Dimensions:

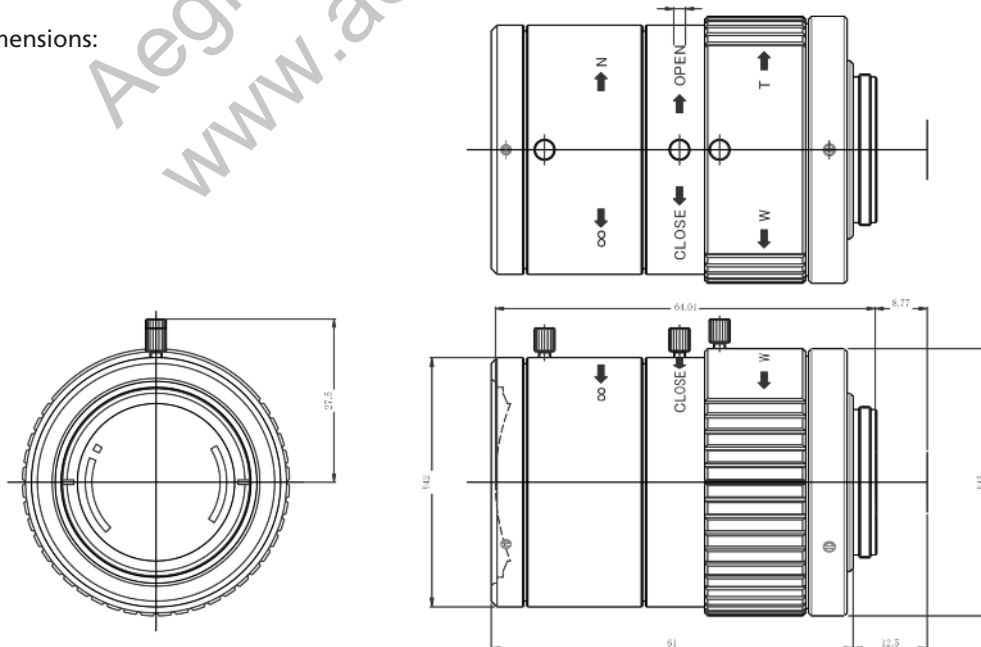

Specifications are subject to change without notice.