

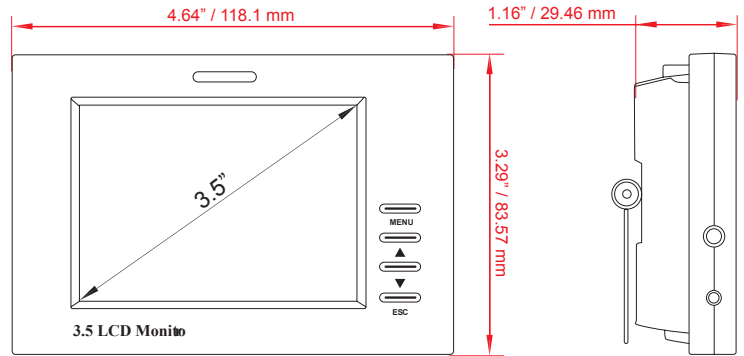

VZ-35SM ADVANTAGES

- 3.5" Black Sunlight Readable LED Test Monitor
- 320 x 240 Resolution
- Low Power Consumption
- BNC, Rechargeable Battery, Wrist Strap
- 2-Year Warranty

DIMENSIONS



| MODEL # | VZ-35SM | |
|--|---|--------------------------------------|
| VIDEO | | |
| Screen Size | 3.5" | |
| Max. Resolution | 320 x 240 @60Hz | |
| Pixel Pitch | 0.248 mm x 0.248 mm | |
| Brightness | 250cd/m ² (Typical) | |
| Contrast Ratio | 350:1 | |
| Aspect Ratio | 4:3 | |
| Viewing Angle (H/V) | 100°/120° | |
| Display Color | 16.7 Million | |
| Response Time | < 25ms | |
| Video System | NTSC / PAL | |
| INTERFACE | | |
| AV(Composite) In (1.0 Vp-p, 75Ω terminated) | 1 | |
| AV(Composite) Out (1.0 Vp-p, 75Ω terminated) | 1 | |
| AUDIO | | |
| Built in speaker | 1W X 1 | |
| SPECIAL FEATURES | | |
| Power Saving | Low Power NI-MH Battery | |
| Sunlight Readable | YES | |
| Multi-lingual Language | English, Italian, Simplified Chinese | |
| DIMENSIONS & WEIGHT | | |
| Outline Dimension (W x H x D) | 4.64" x 3.29" x 1.16" | |
| | 118.1 mm x 83.57 mm x 29.46 mm | |
| Net Weight / Gross Weight | 0.55 lbs (0.25 kg) / 2.0 lbs (0.9 kg) | |
| GENERAL | | |
| Power | Electrical Ratings | DC 12V, 1.5A (AC100 ~ 240V[50/60Hz]) |
| | Consumption (Max / Min) | 4.05 W / 3.15 W |
| Warranty | Parts/ Labor | 2 Year / 2 Year |
| | MTBF (Approx.) | 30,000 Hours |
| Operating Temperature | 32 - 140°F / 0 - 60°C | |
| Operating Humidity | 5 ~ 95% RH | |
| Regulations | CE, WEEE | |
| Package Include | Power Charger AA NI-MH Battery 4 pcs AV Cable 1(AV Input) AV Cable 2(AV Output) Wrist Strap | |

INTERFACE

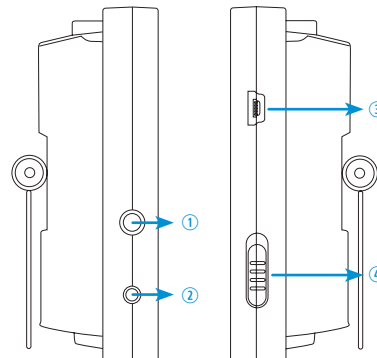

1. AV(composite) IN
2. AV(composite)OUT
3. DC 12V IN
4. POWERON / OFF

Contact ViewZ

- Address : 177 W. Orangethorpe Ave., Placentia, CA 92870
- Phone : (714) 996-1177, Fax : (714) 996-1138
- Sales : sales@viewzusa.com
- Specification subject to change without notice.