

This information is brought to you by:



ELECTRONIC GROUP, INC

480-635-8400 p * aegis-g2@aegiselect.com

<http://www.aegis-elec.com>



KNC-SPDNI120

IP PTZ Camera

- 1/2.8" SONY Exmor CMOS
- 2.1 Megapixel
- Min. Illumination of 0.1 Lux
- 12x Optical Zoom Lens
- True Day & Night with ICR Mechanism
- IP66 (Weather Resistant)
- AV 24V Power

IP

HDTV / Megapixel

Network Cameras

KNC-SPDNI120

IP PTZ Camera



IP
HDTV / Megapixel
Network Cameras

- 1/2.8" SONY Exmor CMOS
- 2.1 Megapixel
- Min. Illumination of 0.1 Lux
- 12x Optical Zoom Lens
- True Day & Night with ICR Mechanism
- IP66 (Weather Resistant)
- AV 24V Power



FC | CE

General Feature Diagram Unit: (mm)

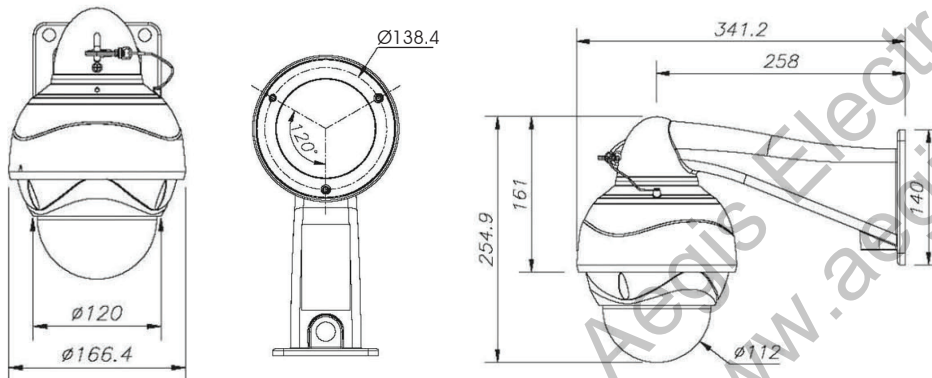

Connection Diagram

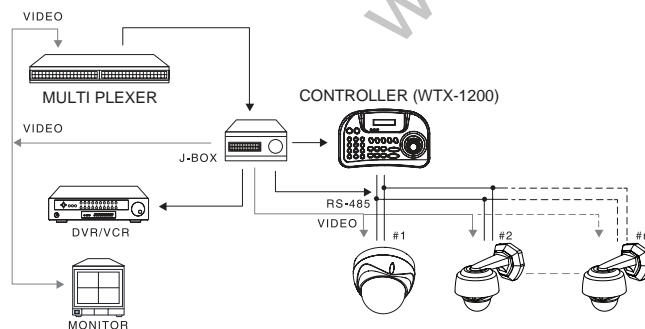

Technical Specification

Camera	Image Sensor	3.27 Megapixel, 1/2.8" SONY Exmor CMOS		
	Total Pixels (H x V)	2144 x 1588		
	Day & Night	True Day & Night with ICR Mechanism		
	Min. Illumination	0.1 Lux / F2.0		
Lens	Shutter Speed	1/30 ~ 1/10,000		
	Lens	12x Optical / 10x Digital Zoom (f=5 ~ 60mm)		
Video	Lens Type	12x Optical Zoom Lens		
	Maximum Resolution	H.264	1920 x 1080 (16:9)	MJPEG 1280 x 720 (16:9)
	Frame Rate	H.264	30fps	MJPEG 30fps
	Compression	H.264 MJPEG		
	Streaming	Dual-Stream at different frame rate and bandwidth		
	Digital Slow Shutter	2X ~ 64X		
	Image Settings	Brightness, Contrast, Saturation, Sharpness, White balance, Exposure control, Image rotation, Text and image overlay, Privacy masking, BLC		
Audio	Streaming	Two-way, full duplex		
	Compression	G.711, G.726		
	Input / Output	External Microphone or Line Input / Line Output		
Network	LAN	Ethernet 10/100 Base-T (RJ-45 Type)		
	Security	Multiple user access levels with password protection, HTTPS (SSL)		
	Protocol	IPv4, HTTP, TCP, RTSP, RTP, UDP, IGMP, RTCP, SMTP, FTP, ICMP, DHCP, ARP, DNS, DDNS, HTTPS, UPnP		
	ONVIF Compliant	Yes		
	Interface	OS	Windows XP, Vista, 7	Browser Internet Explorer
Intelligent Video	Video Motion Detection	Yes		
Alarm and Event	Alarm Triggers	Intelligent video, external inputs, manual triggers, network fail, reboot		
	Alarm Events	JPEG image upload via FTP & Email, notification via E-mail, external output activation		
General	Processors	CPU: ARM 926EJ-S		
	Memory	RAM: 128 MB, Flash: 64 MB		
	Power	PoE class 4 (IEEE 802.3at Type2) AC24V 38.5W (Heater on)		
	Interface	Analog Composite Output Power (AC24V) Input Sensor Input x 1 / Alarm Output x 1 Audio Input x 1 / Audio Output x 1 RS485, Status LED		
	IP Rating	IP66 (Weather Resistant)		
	Operating Temperature	-40 °F ~ 122 °F (-40 °C ~ 50 °C)		
	Dimension	Bubble (Φ4.4), Φ6.5 x 13.4 x 10 inch (Bubble (Φ112), Φ166 x 341 x 255 mm)		
Weight	7.7 lbs (3500 g)			