

SENTECH **STC-160BC/165BC**

**1/3" CCD
Industrial Machine
Vision Camera**



The STC-160BC series industrial monochrome camera provides excellent performance for low cost machine vision solutions. The camera features high quality reproduction, a 1/3" high resolution IT CCD, electronic shutter to 1/100,000 of a second, HD/VD external sync input, and a 12 pin connector for easy access of power, video signal and sync signals. The STC-160BC is available in EIA and CCIR formats.

Features:

- AGC / Manual Gain
- Composite Outputs
- 1/3" IT CCD, 768(V) x 494(H)
- Electronic Shutter
- External Sync, (HD/VD) input
- Small size, Lightweight
- 570 TV Lines
- 12 pin Connector
- EIA & CCIR Formats
- 0.2 Lux Minimum Illumination
- 12VDC
- Uses 'CS' mount lenses, 'C' w/adaptor

STC-160BC/165BC

Technical Specifications

STC-160BC / STC-165BC

- 768(H) x 494(V) 1/3" IT CCD (STC-160, EIA)
- 752(H) x 582(V) 1/3" IT CCD (STC-165, CCIR)
- Horizontal Frequency: 15.734kHz (EIA), 15.625kHz (CCIR)
- Vertical Frequency: 59.97Hz (EIA), 50.00Hz (CCIR)
- Sync System: Internal or HD/VD
- Horizontal Resolution: 570 Lines
- Minimum Illumination: 0.2 Lux at F1.2 (AGC On)
- S/N Ratio: More than 56dB (AGC Off)
- Gamma: 0.45 / 1.0
- Backlight Compensation On/Off
- Gain: AGC, Fixed, Manual Adjust
- Electronic Auto CCD Shutter: 1/60 (EIA) 1/50 (CCIR) 1/100,000 Sec
- Manual Shutter Adjust: 8 Steps, 1/60 (EIA), 1/50 (CCIR) 1/100,000 Sec
- Video Output: 1.0p-p 75 ohms
- Power: 10-12 VDC 135mA
- Operating Temperature: -10degrees C to +40 degrees C (14F-104F)
- Weight: 190g
- Dimensions: w/cs mount 51(W) x 51(H) x 55.5(D)

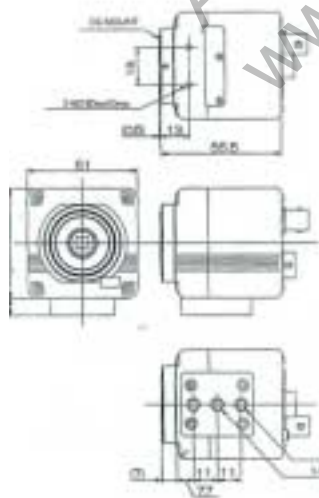

Weights and dimensions shown are approximate. Specifications are subject to change without notice. These products may be subject to export control regulations.



This information is brought to you by:

SENTECH

Aegis

ELECTRONIC GROUP, INC
480-635-8400 p * aegis-g2@aegiselect.com
<http://www.aegis-elec.com>