

## STC-R920M

The STC-R920M is a board level black and white camera specifically developed for silicon wafer inspection. This camera features a 10 bit DSP which is programmable by Sentech for your application. The STC-R920M is a single compact board, slightly larger than a credit card, with a remote head CCD. The CCD board is 25 (W) x 20 (H) mm with a 67mm (2.7") wire harness separating it from the CCU board.

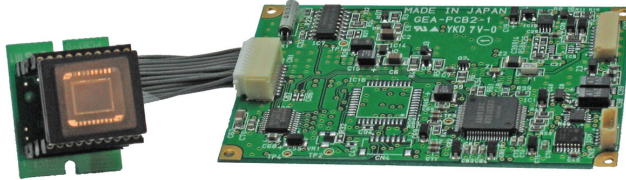

STC-R920M

Image shown not actual size

### Features

- 1/2" B/W CCD Format
- DSP Programmable
- Mirror Imaging
- Field or Frame Accumulation
- EIA & CCIR Formats
- Available in EIA and CCIR Format

### Specifications >>

Image Sensor:	B/W 1/2 768 (H) x 494 (V) (ICX418ALL - EIA) (ICX419ALL - CCIR)
Signal Format:	EIA ( Also available in CCIR format STC-R925M)
Scanning System:	2:1 Interlace
CCD Size:	7.40 (H) x 5.95 (V) mm
Pixel Cell Size:	8.4 (H) x 9.8 (V) $\mu$ m
Scanning Area:	6.45 (H) x 4.84 (V) mm
Pixel Clock Frequency:	14.318 MHz
Horizontal Sync Frequency:	15.734 KHz
Vertical Sync Frequency:	59.94 Hz
Horizontal Resolution:	560 TV Lines
Vertical Resolution:	350 TV Lines (Field Integration) / 485 TV Lines (Frame Integration)
Gamma:	1.0 (Sentech Programmable)
Integration Mode:	Field or Frame Accumulation DSP Selectable
DSP: (Sentech Programmable)	Mirror Image Analog Gain Control (AGC) 8 - 22dB Digital Gain Control (DGC) 0 - 14 dB AGC / Fixed Gain (Selectable) Aperture Control Video Setup Level
Electronic Shutter	1/30 (EIA) (Default Setting)
Gain:	Sentech Programmable
Video Output:	1.0 v p-p, 75 $\Omega$
S/N Ratio:	56dB (Gain Minimum)
Minimum Illumination:	0.05 Lux @ F1.2 (50 IRE)
Operating Voltage:	DC + 12 Volts $\pm$ 10%
Power Consumption:	147 mA
Operating Temperature:	-10°C ~ 45°C (14°F ~ 113°F)
Storage Temperature:	-30°C ~ 60°C (-22°F ~ 140°F)
Dimensions:	Main Board: 50 (W) x 11.2 (H) x 75 (D) mm (2" x .45" x 3") CCD Board: 25 (W) x 20 (H) x 9 (D) mm (1" x .8" x .36") (Not including Connectors)
Weight:	23g (.81 oz.)
Power Supply:	DC + 12 Volts $\pm$ 10%
Connections:	10 Pin wire harness (Power, Sync, Video)

## >> STC-R920M

### Mechanical Drawings

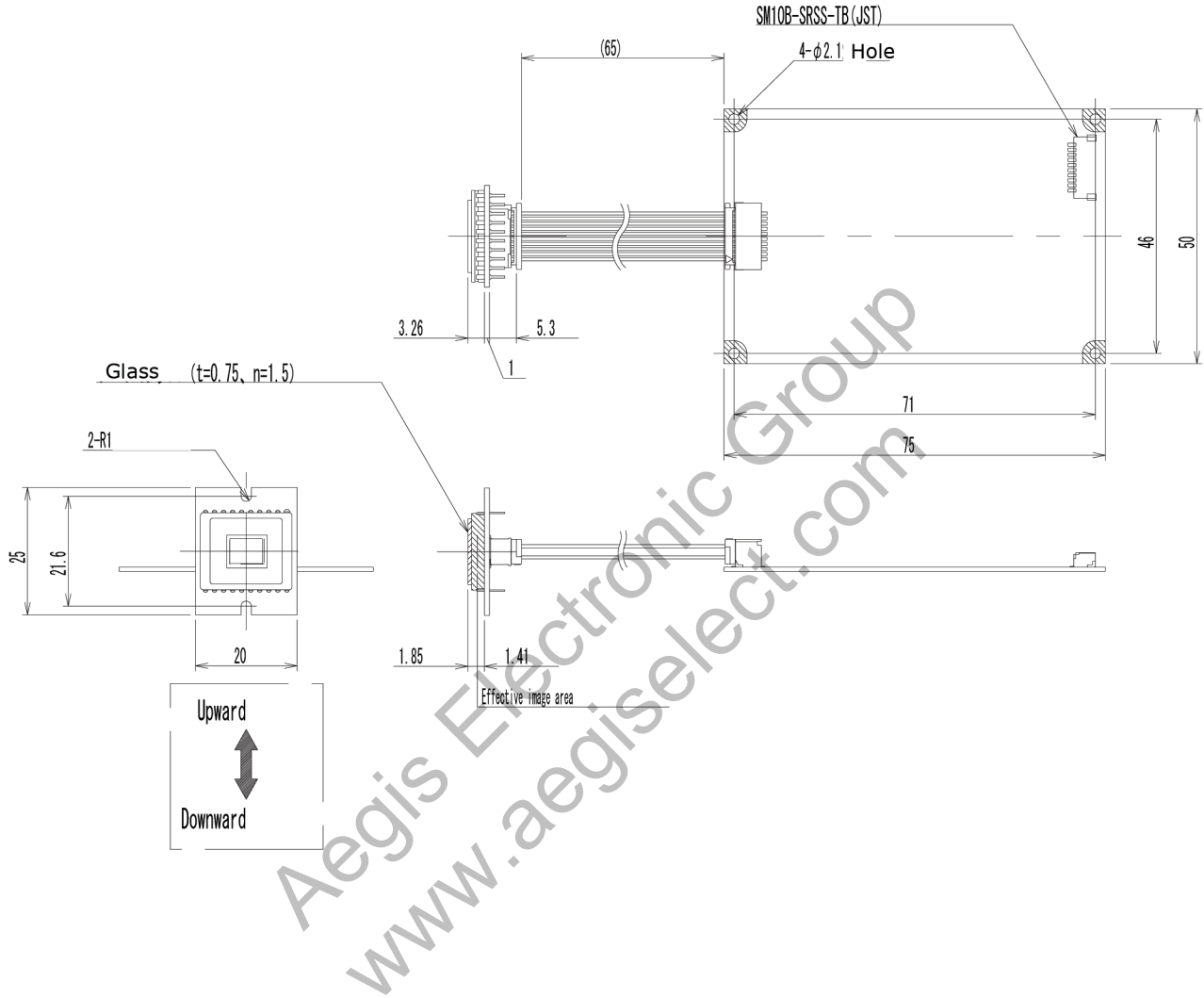

**Note:** (Dimensions are given in mm)

This information is brought to you by: