

STC-172

The STC-172 Series is a 1/2" Black & White high resolution machine vision board camera. The STC-172 offers a integration HOLD feature for special applications. Also, the STC-172 offers frame/field integration and accepts external non-interlace synchronization.

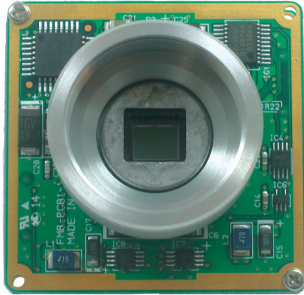

STC-172CS



Images shown not actual size

Features

- 1/2" B/W CCD
- Machine Vision
- High Resolution
- EIA & CCIR Formats
- External Sync (HD/VD)
- Frame & Field Integration
- Integration HOLD Feature
- C - Mount

Specifications >>

Image Sensor:	Black & White: 1/2" Interline CCD (CX418ALL)
Effective Picture Element:	768 (H) x 494 (V)
Signal Format:	EIA (CCIR Format also Available - STC-177CS)
Scanning System:	2:1 Interlace/ Non-Interlace with External Sync
Horizontal Frequency:	15.734 kHz
Vertical Frequency:	59.94 Hz
Sync System:	Internal or External (HD/VD) Auto Switching By HD Input
Horizontal Resolution:	570 TV Lines
Vertical Resolution:	Frame Accumulation: 485 TV Lines Field Accumulation: 350 TV Lines
Minimum Illumination (Standard Version):	0.13 Lux @ F 1.2 (AGC: On)
Minimum Illumination (H Version):	0.02 Lux @ F 1.2 (AGC: On)
S/N Ratio:	>56dB (AGC Off)
Accumulation Mode:	Frame / Field Switchable
Gamma:	0.45 / 1 Switchable
Lens Mount:	C Mount
Gain:	AGC/Fixed, Manual Adjust
Electronic Shutter:	Field: 1/60 (1/50), 1/100 (1/120), 1/250, 1/500, 1/1000, 1/2000, 1/4000, 1/10,000 Frame: 1/30 (1/25), 1/60 (1/50), 1/100 (1/120), 1/250, 1/500, 1/1000, 1/2000, 1/4000, 1/10,000
Lens Mount:	C Mount Lens Mount
Video Output:	VS 1.0Vp-p, 75 Ω
Power Supply:	12V DC
Power Consumption:	110mA
Operating Temperature:	-10°C ~ 45°C (14°F ~ 113°F)
Storage Temperature:	-30°C ~ 60°C (-22°F ~ 140°F)
Dimensions:	45 (W) x 45 (H) x 26 (D) mm (1.8" x 1.8" x 1)
Weight:	45g (1.58 oz.)

>> STC-172CS

Mechanical Drawings

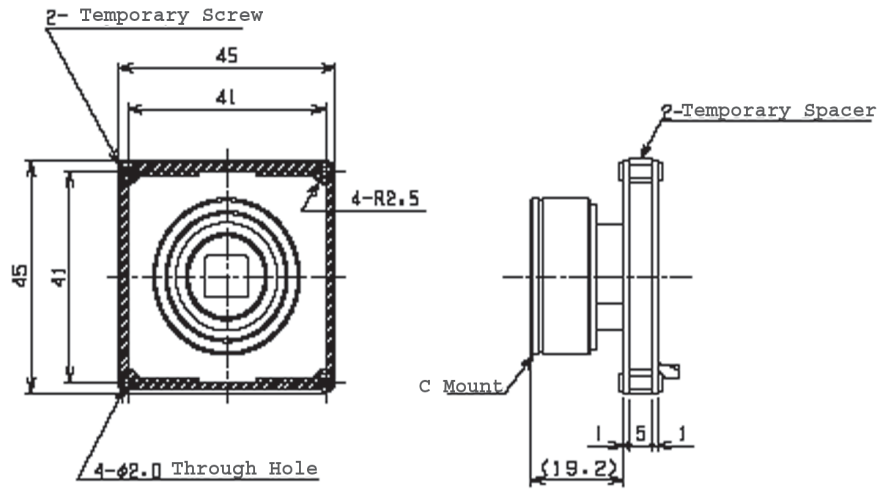

1. Connector and DIP Switch

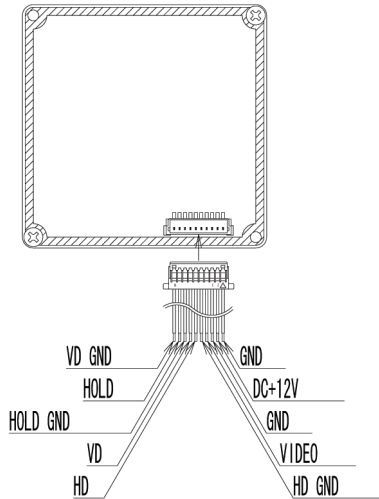

Dip Switch



Switch Number	Function	Switch Position	
		ON	OFF
1	Shutter Speed Setting	See Table 2	
2			
3			
4	Accumulation Mode and Shutter Mode Setting	See Table 1	
5			
6	No Function	-	-

2. Functional Explanation of DIP Switch and VR

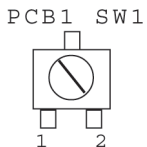

EPCB SW1: Fix Gain / AGC Change

On Board Marking "1" side: Fixed Gain

On Board Marking "2" side: AGC

EPCB VR1: When the PCB1 SW1 is set to "fixed gain", the fixed gain value can be adjusted by this VR (0dB ~ XXdB)

(Caution) Do not adjust any other adjustments except PCB1 - VR1 as they are critical factory default setup adjustment.

1. Accumulation Mode and Shutter Mode Setting

Mode	Function	SW4	SW5
Field	Electronic Shutter as Defined in the Next Table	OFF	OFF
Field	Electronic Shutter OFF (1/60)	ON	OFF
Frame	Electronic Shutter as Defined in the Next Table	OFF	ON
Frame	Electronic Shutter OFF (1/30)	ON	ON

2. Shutter Speed Setting

Shutter Speed	SW 1	SW 2	SW 3
1/60	OFF	OFF	OFF
1/100	ON	OFF	OFF
1/250	OFF	ON	OFF
1/500	ON	ON	OFF
1/1000	OFF	OFF	ON
1/2000	ON	OFF	ON
1/4000	OFF	ON	ON
1/10000	ON	ON	ON

Note: (Dimensions are given in mm)