

H6Z0812

6X 8~48 mm F1.2
for 1/2" format camera
C-Mount

Model No.	H6Z0812		Effective Front	φ 32.9 mm
Focal Length	8~48 mm		Lens Aperture Rear	φ 16.6 mm
Max. Aperture Ratio	1:1.2		Back Focal Length	11.4 mm
Max. Image Format	6.4×4.8 mm (φ8 mm)		Flange Back Length	17.526 mm
Operation	Iris	Manual, F1.2~16C	Mount	C-Mount
	Focus	Manual, 1.2 m~Inf.	Filter Size	M49 P=0.75 mm
	Zoom	Manual, 8~48 mm	Dimensions	φ51.75 X 97 mm
Object Dimension at M.O.D.	8 mm	98.4 × 72.2 cm	Weight	305 g
	48 mm	16.8 × 12.8 cm		
Angle of View	D	55.8° ~ 9.9°	1/3"	41.8° ~ 7.5°
	H	44.6° ~ 8.0°		33.5° ~ 6.1°
	V	33.5° ~ 6.1°		25.2° ~ 4.6°

1/2

C

M.O.D. : Minimum Object Distance

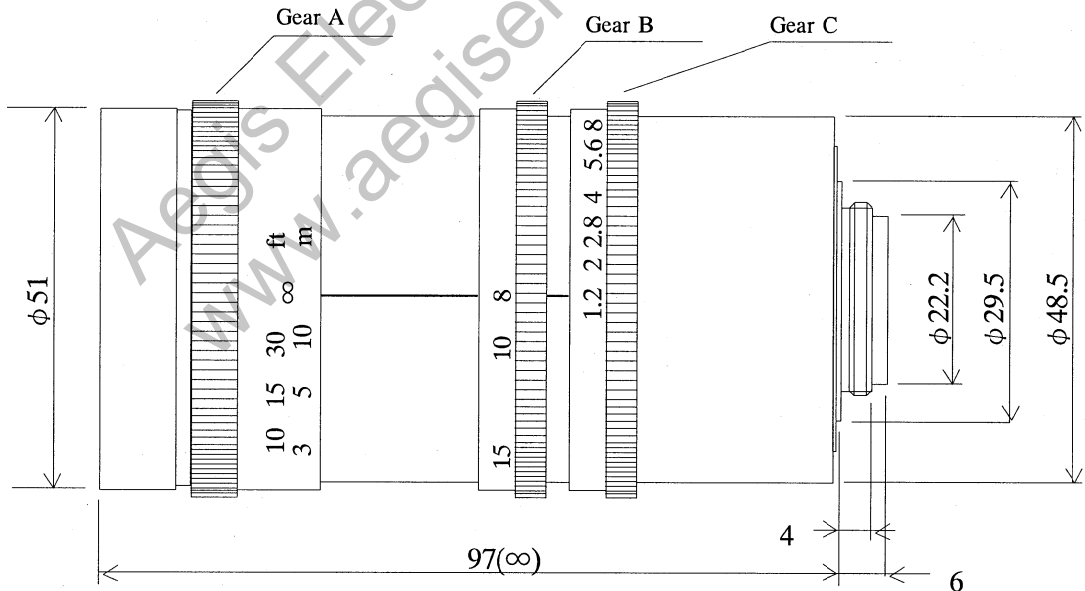

Z

This information is brought to you by:



ELECTRONIC GROUP, INC
480-635-8400 p * aegis-g2@aegiselect.com
http://www.aegis-elec.com

Gear	A, B, C
Pitch Diameter	φ51.75 mm
No. of Teeth	115
Module	0.45