



- **1.4 MEGAPIXEL RESOLUTION**
- **15 FPS AT FULL RESOLUTION**
- **EXCELLENT SENSITIVITY**
- **GLOBAL ELECTRONIC SHUTTER**
- **LIGHT, COMPACT, ROBUST**
- **LOCKING MINI USB 2.0 CONNECTOR**

Outline

Lumenera's new Lm165 mini CCD USB 2.0 megapixel cameras are designed to be used in a wide variety of industrial and scientific applications, particularly those with low-light conditions where high dynamic range is required, and with tight space constraints.

Measuring 44x44x56mm, these compact cameras offer the same performance as our enhanced USB 2.0 camera line, delivering outstanding image quality and value. Features include new locking industrial mini USB and RJ45 GPI/O connector, multiple mounting points, 15 fps at full 1392x1040 resolution, 30 fps 640x480 binning mode, and on-board processing. Both color and monochrome product models are available.

Electronic Global Shutter provides capabilities similar to a mechanical shutter, allowing simultaneous integration of the entire pixel array - ideal for capturing objects in high-speed motion and strobe lighting.

Uncompressed images in live streaming video and still image capture are provided across a mini USB 2.0 digital interface. No framegrabber is required. Advanced camera control is available through a complete Software Developer's Kit (SDK), with sample code available to quickly integrate camera functions into OEM applications.

Hardware and software based synchronization trigger is provided standard. 32 MB on-board memory is available for frame buffering.

All Lumenera products are supported by an experienced team of software developers and application engineers. We understand your imaging needs and are here to help you with your integration and development.

Performance Features

- ❑ **Small form factor measuring 44x44x56mm**
- ❑ **Highest quality CCD sensor with electronic global shutter**
- ❑ **Locking industrial mini USB and RJ45 GPI/O connector for control of peripherals and synchronization of lighting**
- ❑ **3 software configurable bidirectional I/O and 2 optically isolated ports (1in/1out)**
- ❑ **Based on Lw camera platform with 32 MB RAM**
- ❑ **Excellent sensitivity with high color fidelity**
- ❑ **Simplified cabling – video, power and full camera control over a single mini USB cable**
- ❑ **Color or monochrome, Interline transfer progressive scan, 1.4 megapixel CCD sensor**
- ❑ **Binning and Region of Interest (ROI) options improve sensitivity and provide higher frame rates**
- ❑ **Select 8 or 12-bit pixel data**
- ❑ **8 mounting points**
- ❑ **FCC Class B, CE Certified**
- ❑ **DirectShow compatible**
- ❑ **USB cameras are software compatible with Windows 2K, Windows XP and Windows Vista operating systems**
- ❑ **Complete SDK available**
- ❑ **Full one (1) year warranty**

This information is brought to you by:



ELECTRONIC GROUP, INC

480-635-8400 p * aegis-g2@aegiselect.com

<http://www.aegis-elec.com>

| | |
|--------------------------------|---|
| Image Sensor | 2/3" format, color or mono, 9.0mm x 6.7mm array |
| Effective Pixels | 1392 x 1040, 6.45µm square pixels |
| Frame Rate | 15 fps at 1392 x 1040, 30 fps at 640x480 (binned or ROI) |
| Sensitivity | Extremely High |
| Dynamic Range | 66dB |
| Exposure | Auto / Manual |
| White Balance | Auto / Manual |
| Dimensions (W x H x D) | 44x44x56mm |
| Mass | ~130 grams |
| Power Requirement | USB bus power |
| Power Consumption | ~2.5 Watts |
| Operating Temperature | 0°C to +50°C |
| Operating Humidity | 5% - 95%, Non-condensing |
| Interface Connector | Locking mini USB cable & RJ45 GPIO connector |
| Lens Mount (Lens not included) | Adjustable C-Mount (CS-Mount option) |

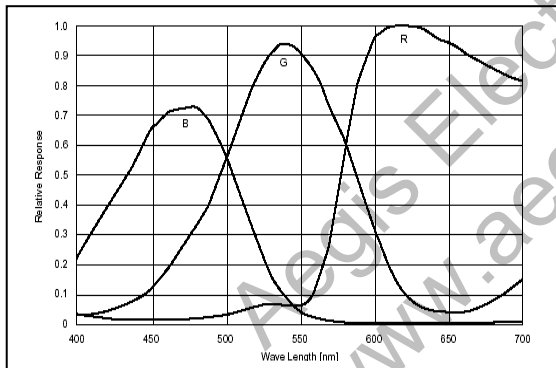

Color Response

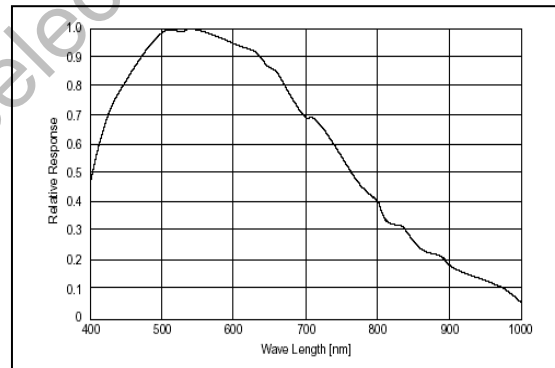

Monochrome Response

Full customization available to meet your exact needs!

Available Options:

- Without Standard IR-Cut Filter
- Without Glass
- Without Mount
- Board Level
- Adjustable CS-Mount

Contact us for more specific details.

Ordering Information

- Lm165C – Mini Enclosed Color Camera
- Lm165M – Mini Enclosed Monochrome Camera
- LuSDK – Software Developer's Kit
- Lu905 – Tripod Mount

Lm165 Camera:

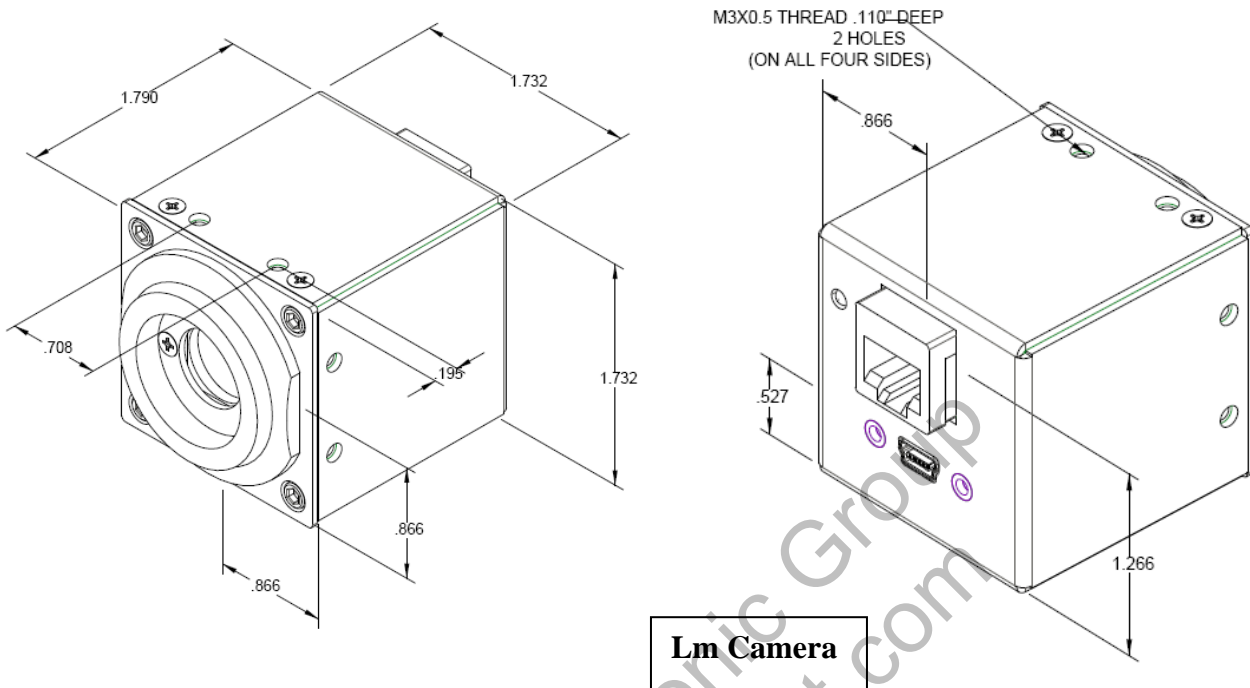

Tripod Mount Attachment:

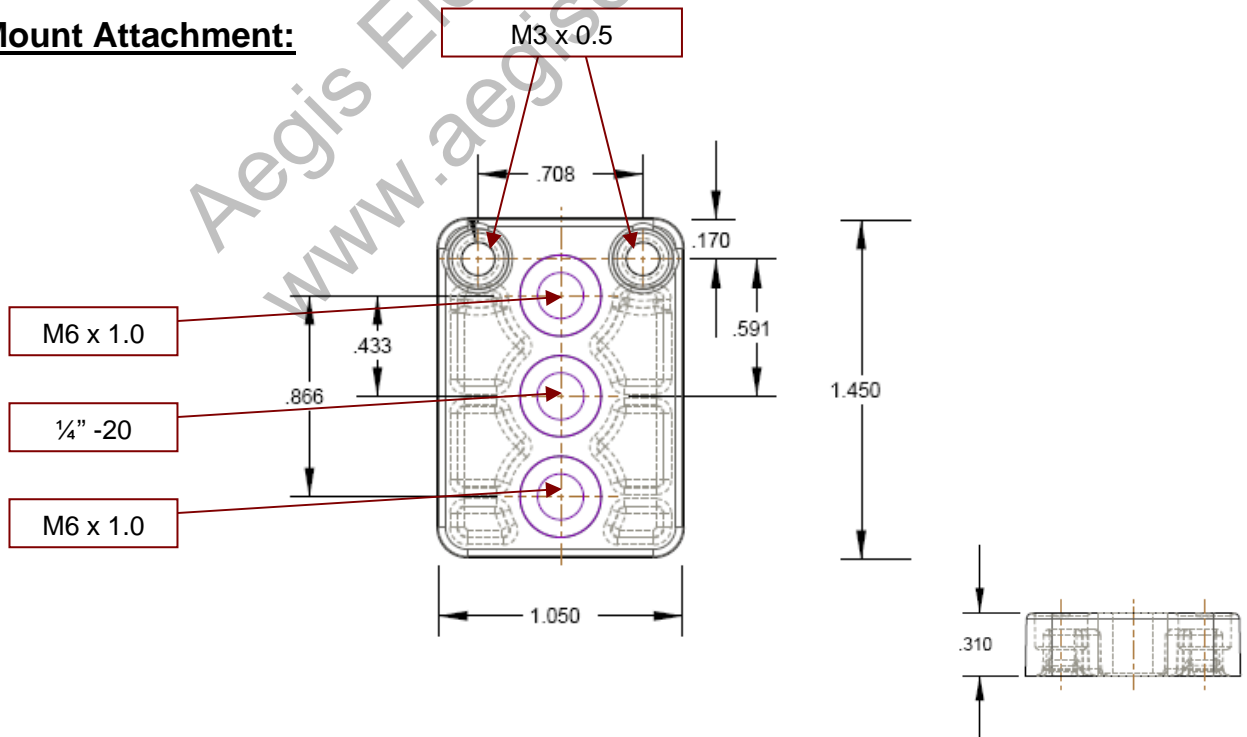

This information is brought to you by:

