



- **1.4 MEGAPIXEL RESOLUTION**
- **15 FPS AT FULL RESOLUTION**
- **EXCELLENT SENSITIVITY**
- **GLOBAL ELECTRONIC SHUTTER**
- **LIGHT, COMPACT, ROBUST**
- **LOCKING MINI USB 2.0 CONNECTOR**

## Outline

Lumenera's new Lm135 mini CCD USB 2.0 megapixel cameras are designed to be used in a wide variety of industrial and scientific applications, particularly those with low light conditions and tight space constraints.

Measuring 44x44x56mm, these compact cameras offer the same performance as our enhanced USB 2.0 camera line, delivering outstanding image quality and value. Features include new locking industrial mini USB and RJ45 GPI/O connector, multiple mounting points, 15 fps at full 1392x1040 resolution, 30 fps 640x480, and on-board processing. Both color and monochrome product models are available.

Electronic Global Shutter provides capabilities similar to a mechanical shutter, allowing simultaneous integration of the entire pixel array - ideal for capturing objects in high-speed motion and strobe lighting.

Uncompressed images in live streaming video and still image capture are provided across a mini USB 2.0 digital interface. No framegrabber is required. Advanced camera control is available through a complete Software Developer's Kit (SDK), with sample code available to quickly integrate camera functions into OEM applications.

Hardware and software based synchronization trigger is provided standard. 32MB on-board memory is available for frame buffering.

All Lumenera products are supported by an experienced team of software developers and application engineers. We understand your imaging needs and are here to help you with your integration and development.

## Performance Features

- Small form factor measuring 44x44x56mm**
- High quality CCD sensor**
- Locking industrial mini USB and RJ45 GPI/O connector for control of peripherals and synchronization of lighting**
- 3 software configurable bidirectional I/O ports and 2 optically isolated ports (1in/1out)**
- Based on Lw camera platform with 32MB RAM**
- Excellent sensitivity with high color fidelity**
- Simplified cabling – video, power and full camera control over a single mini USB cable**
- Color or Monochrome, Interline transfer Progressive scan, 1.4 Megapixel CCD sensor**
- Binning and Region of Interest (ROI) options improve sensitivity and provide higher frame rates**
- Select 8 or 12-bit pixel data**
- 8 mounting points**
- FCC Class B, CE Certified**
- DirectShow compatible**
- USB cameras are software compatible with Windows 2K, Windows XP, and Windows Vista operating systems**
- Complete SDK available**
- Full one (1) year warranty**

This information is brought to you by:



**ELECTRONIC GROUP, INC**

480-635-8400 p \* aegis-g2@aegiselect.com  
<http://www.aegis-elec.com>

# Specifications

# Lm135

Image Sensor	1/2" format, color or mono, 6.5mm x 4.8mm array
Effective Pixels	1392x1040, 4.65µm square pixels
Frame Rate	15 fps at 1392x1040, 30 fps at 640x480 (binning or ROI)
Sensitivity	High
Dynamic Range	60dB
White balance	Auto / Manual
Exposure	Auto / Manual
Dimensions (W x H x D)	44x44x56mm
Mass	~130 grams
Power Requirement	USB bus power
Power Consumption	~2.5 Watts
Operating Temperature	0°C to +50°C
Operating Humidity	5% - 95%, Non-condensing
Interface Connector	Locking mini USB cable & RJ45 GPIO connector
Lens Mount (Lens not included)	Adjustable C-Mount (CS-Mount option)

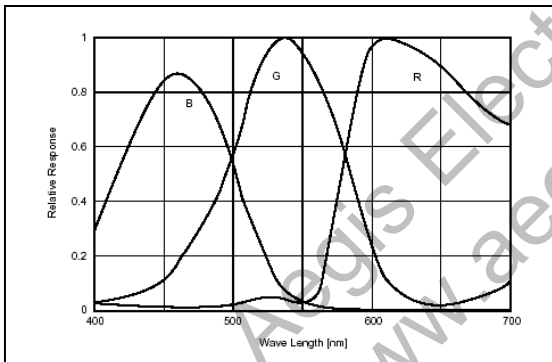

Color Response Curve

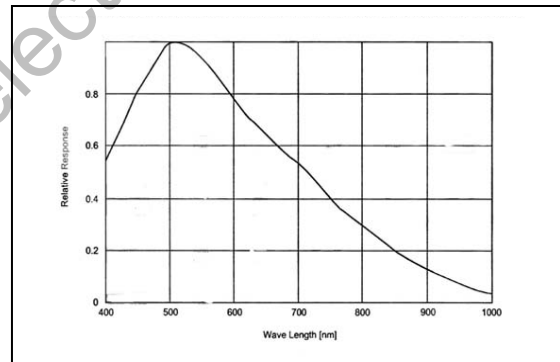

Mono Response Curve

**Full customization available  
to meet your exact needs!**

**Available Options:**

- Without Standard IR-Cut Filter
- Without Glass
- Without Mount
- Board Level
- Adjustable CS-Mount

Contact us for more specific details.

**Ordering Information**

- Lm135C – Mini Enclosed Color Camera
- Lm135M – Mini Enclosed Monochrome Camera
- LuSDK – Developer's Kit and Accessories
- Lu905 – Tripod Mount

## Lm135 Camera:

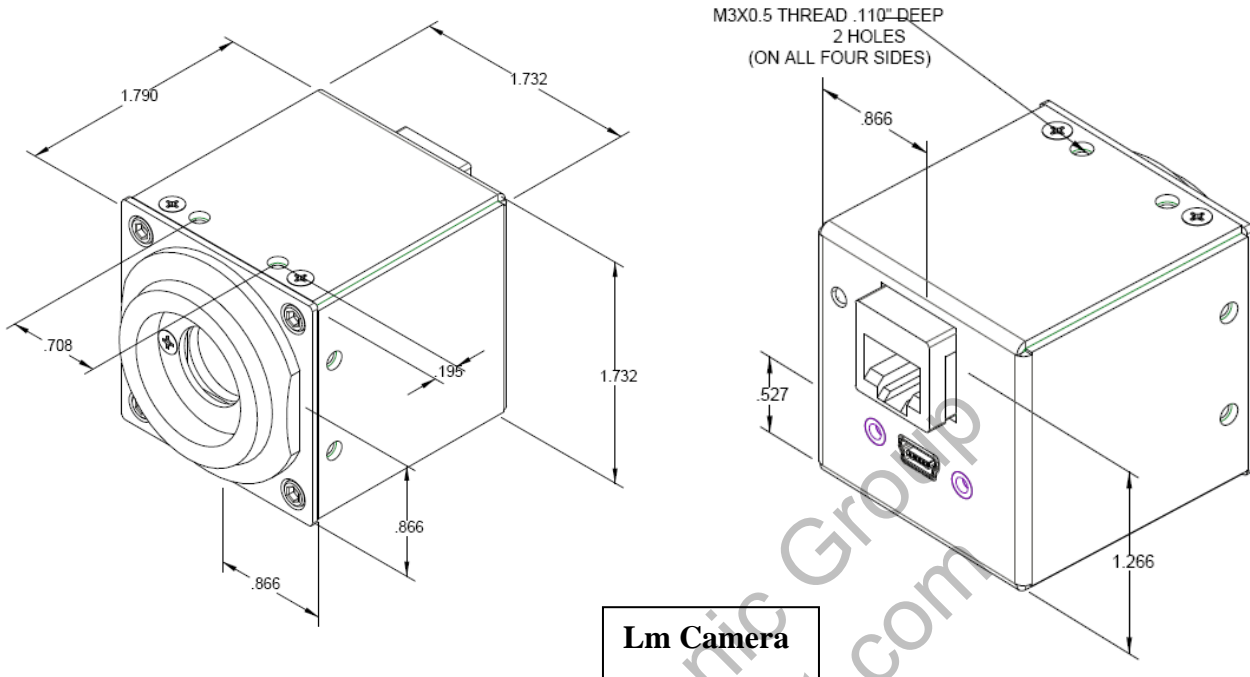

## Tripod Mount Attachment:

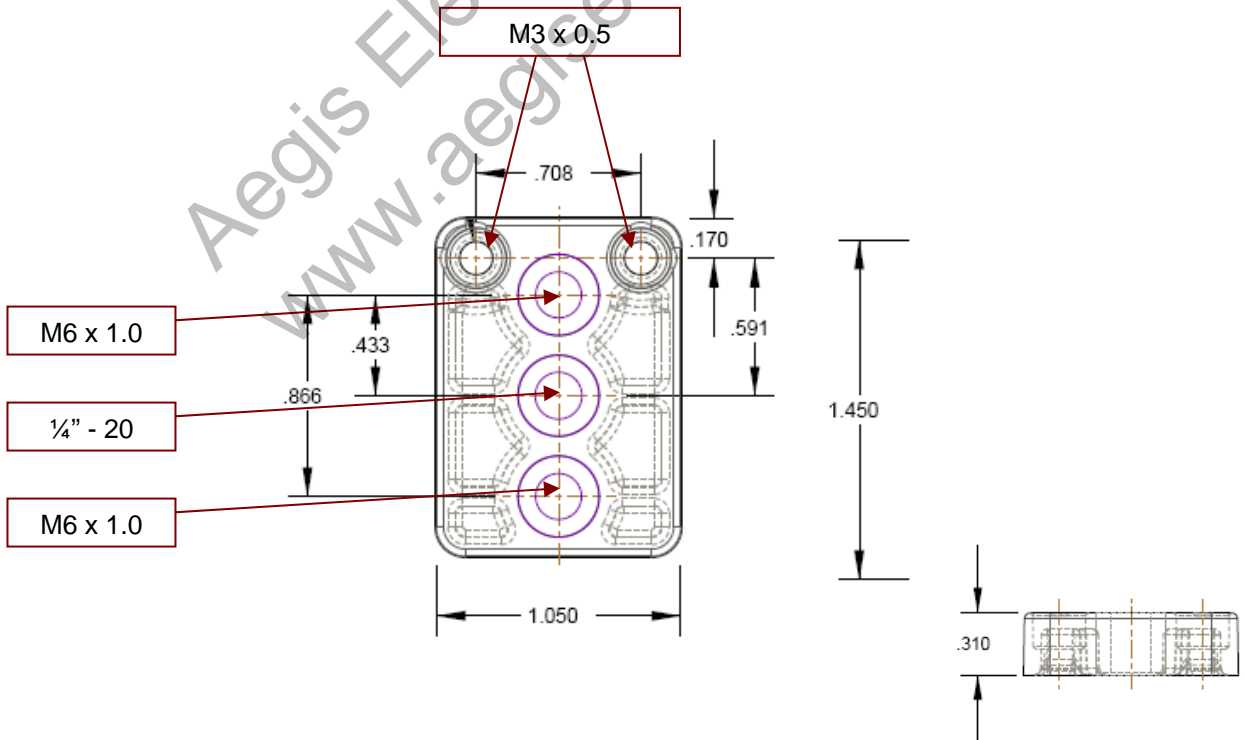

This information is brought to you by:

