

This information is brought to you by:



ELECTRONIC GROUP, INC
480-635-8400 p * aegis-g2@aegiselect.com
<http://www.aegis-elec.com>

SENTECH

Aegis Electronic Group
www.aegiselect.com

STC-HD93 Series DVI & SDI Output Product Specification

16:9 Format 720p Color Camera

Safety Precautions

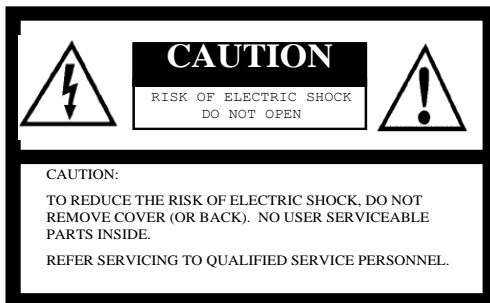

The lightning flash with arrowhead symbol, within an equilateral triangle, is intended to alert the user to the presence of uninsulated “dangerous voltage” within the product’s enclosure that may be of sufficient magnitude to constitute a risk of electric shock to persons.



The exclamation point within an equilateral triangle is intended to alert the user to the presence of important operating and maintenance (servicing) instructions in the literature accompanying the appliance.

For U.S.A.

Warning:

This equipment generates and uses radio frequency energy and if not installed and used properly, I.e., in strict accordance with the instruction manual, may cause harmful interference to radio communications. It has been tested and found to comply with the limits for a Class A computing device pursuant to Subpart J of Part 15 of FCC Rules, which are designed to provide reasonable protection against such interference when operated in a commercial environment.

For Canada

Warning:

This digital apparatus does not exceed the Class A limits for radio noise emissions from digital apparatus set out in the Radio Interference Regulations of the Canadian Department of Communications.

WARNING:

TO PREVENT FIRE OR SHOCK HAZARD, DO NOT EXPOSE THIS APPLIANCE TO RAIN OR MOISTURE.

Product Precautions

- Handle the camera with care. Do not abuse the camera. Avoid striking or shaking it. Improper handling or storage could damage the camera.
- Do not pull or damage the camera cable.
- During camera use, do not wrap the unit in any material. This will cause the internal temperature of the unit to increase.
- Do not expose the camera to moisture, or do not try to operate it in wet areas.
- Do not operate the camera beyond its temperature, humidity and power source ratings.
- While the camera is not being used, keep the lens or lens cap on the camera to prevent dust or contamination from getting in the CCD or filter area and scratching or damaging this area.
- Do not keep the camera under the following conditions:
 - In wet, moist, and high humidity areas
 - Under hot direct sunlight
 - In high temperature areas
 - Near an object that releases a strong magnetic or electric field
 - Areas with strong vibrations
- Use a soft cloth to clean the camera. Use pressured air spray to clean the surface of the glass. DO not scratch the surface of the glass.

Copyright & Disclaimer

Sensor Technologies America, Inc. (DBA Sentech America) believes the contents and specifications of its website, catalog, documentation and ads are correct; however, Sentech America provides no representation or warranty regarding such information or product(s) contained therein. It is requested that Sentech America be given appropriate acknowledgement in any subsequent use of such work by a third party.

While every effort has been made to ensure that the details contained in Sentech America's website and all documentation are correct and up-to-date, Sentech America assumes no liability, legal or otherwise for any errors in listings, specifications, part numbers, process, software or model applications. Sentech America reserves the right to change specifications, product descriptions, product quality, pricing and application at any time without prior written or oral notice. Any party using such information assumes all risk for any and all damaged caused to themselves, a third party and/or property by virtue of incorrect information and/or failure of these products. By installing and/or using a Sentech America software development kit or other similar product and/or information obtained from Sentech America's website, catalog, documentation or ads, you hereby accept and understand these stated terms and conditions.

Aegis Electronic Group
www.aegiselect.com

Contents

I. Introduction	5-6
A. Summary	5
B. Differences between the STC-HD93 and STC-HD133 Series	6
II. Specifications	7-11
A. Electronic / Mechanical / Environmental Specifications	7
B. Spectral Sensitivity Characteristics	8
C. Camera Operations (TBD)	8
D. Shutter Setting.....	9
E. Camera Control Functions	10
F. External Control Board Circuits	11
III. Dimensions	12-20
A. STC-HD93DV.....	12
B. STC-HD93DV-B	13
C. STC-HD93DV-CS.....	14
D. STC-HD93DV-BCS	15
E. STC-HD93DV-BHS	16
F. STC-HD93SDI	17
G. STC-HD93SDI-B	18
H. STC-HD93SDI-CS.....	19
I. STC-HD93DI-BHS	20

I. Introduction

The Specifications below describe the following cameras:

DVI Output:

STC-HD93DV	(C Mount Cased Type)
STC-HD93DV-B	(C Mount Board Type)
STC-HD93DV-CS	(CS Mount Cased Type)
STC-HD93DV-BCS	(CS Mount Board Type)
STC-HD93DV-BHS	(CS Mount Board Type Low Noise)

SDI Output:

STC-HD93SDI	(C Mount Cased Type)
STC-HD93SDI-B	(C Mount Board Type)
STC-HD93SDI-CS	(CS Mount Cased Type)
STC-HD93SDI-BHS	(CS Mount Board Type Low Noise)

A. Summary

- 16:9 720p
- DVI / SDI Output
- Remote Controller on OSD
- High Sensitivity

The STC-HD93 series is the new generation of STC-HD133 Cameras. The new STC-HD93 series still provides a 16:9 aspect ratio with a 720p HD resolution, DVI / SDI Output, and the Remote Controller on the OSD. The new HD93 series features an increased sensitivity (up 3dB) and lower power consumption along with a different chip size.

B. Differences between STC-HD93 and STC-HD133 Series

The full specifications of the STC-HD93 are available in Section II-A. Here are the highlighted differences between the STC-HD93 Series and the STC-HD133 Series.

Parameter		STC-HD93 Series	STC-HD133 Series
Imager		1/3" Diagonal SXGA Color CCD ICX692AQA (Sony)	1/3" Diagonal SXGA Color CCD: ICX445AQA (Sony)
HD active picture elements		1280 (H) x 720 (V)	
Chip size		6.04 (H) x 4.0 (V) mm	6.26 (H) x 5.01 (V) mm
Cell Size		4.08 (H) x 4.08 (V) μm	3.75 (H) x 3.75 (V) μm
Minimum scene illumination		TBD	5 Lux at F1.2
Video output		DVI / HD-SDI	
Camera function		Same	
Power	Input voltage	+ 9 ~ + 15 Vdc (Typical: +12 Vdc)	+ 9 ~ + 15 Vdc (Typical: +12 Vdc)
	Consumption	Less than 2.8W	Less than 3.0W
Dimensions		Same	
Optical filter		Same character, different parts	
Button		Same	

View Angle

Also, the STC-HD93 Series' View Angle is slightly different when compared to the STC-HD133 Series. Please note: the actual view angle will differ depending on the Lens. Please refer to the example below for further explanation.

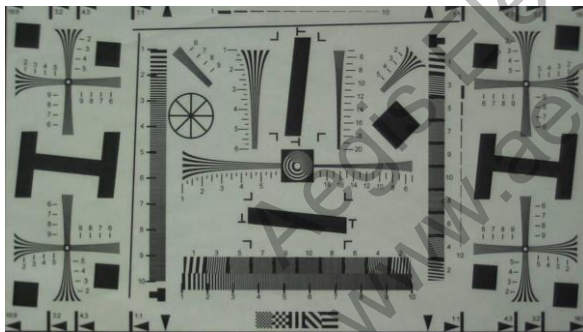

Video image on STC-HD133

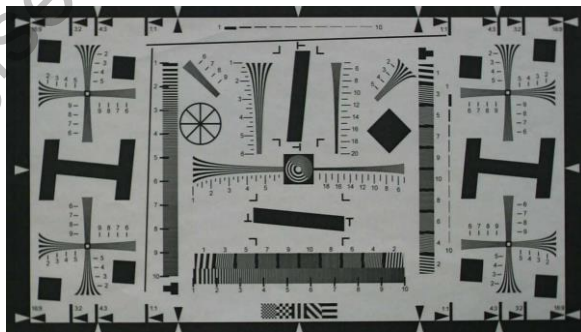

Video image on STC-HD93

Example: View Angle on f=16mm, C Mount Lens

	STC-HD133	STC-HD93
Horizontal	17.2°	18.8°
Vertical	9.7°	10.6°
Diagonal	20.0°	21.8°

II. Specifications

A. Electronic Specifications / Mechanical Specifications / Environmental Specifications

Product		STC-HD93** (Cased type)	STC-HD93**-B (Board type)	Initial Setting	
Electronic specifications	Imager	1/3" interline SXGA CCD: ICX692AQA			
	HD active picture elements	1280 (H) x 720 (V)			
	Chip size	6.04 (H) x 4.0 (V) mm			
	Cell size	4.08 (H) x 4.08 (V) μm			
	Minimum scene illumination	4 Lux at F1.2 at 50 % IRE, AGC ON and 1/60 seconds shutter speed with IR cut filter			
	Resolution	600 TV lines			
	Sync. System	Internal			
	Video output	DVI Model	DVI 1.0 conformity RGB, 1280 (H) x 720 (V), 59.94Hz / 60Hz / 50Hz / 29.97Hz / 30Hz / 25Hz		59.94 Hz
		SDI Model	HD-SDI (SMPTE292M Compliant) YPbPr, 1280 (H) x 720 (V), 60 Hz / 59.94 Hz / 50 Hz		59.94 Hz
	Camera functions				
		ALC	Can be configured via the UART communication with auto electronic shutter and AGC		ALC ON
		Shutter speed	Adjustable shutter speed via the UART communication Up to 1/100,000 seconds at 60 Hz / 59.94 Hz or up to 1/83,947 seconds at 50 Hz		AEE
		Gain	AGC or Fixed gain selectable via the UART communication Gain range: 0 to 18.3 dB		Fixed Gain 0 dB
		Digital gain	Up to 5.9866 dB		0 dB
		Gamma	1.0, 0.9, 0.8, 0.7, 0.6, 0.5, 0.45, 0.3 or manual gamma Selectable gamma via the UART communication		Manual Gamma
		White balance	Auto white balance / manual white balance / push to set white balance Selectable white balance via the UART communication		Auto White Balance
		Mirror image	Normal image and horizontal flip are selectable mirror image via the UART communication		Normal image
		DSP presets	Twenty eight DSP presets Selectable picture mode via the UART communication		Preset 00
		Line generator	Both horizontal and vertical with all available colors Adjustable thickness via the UART communication		No Lines
		Shadow mask generator	Both horizontal and vertical with shading level adjustment via the UART communication		No shadow mask
		Communication	+3.3V UART communication via 3.5Φ stereo jack		
		Character generator	Built-in character generation function via the UART communication		
		Pixel blemish collection	Up to 64 pixel blemish static collection		
Power	Input voltage	+9 to +15 Vdc (Typical: +12 Vdc)			
	Consumption	Less than 2.8W			
Mechanical specifications	Dimensions	40 (W) x 40 (H) x 45.8 (D) mm	35 (W) x 35 (H) x 46.7 (D) mm		
	Optical filter	IR cut filter on			
	Lens mount	C mount/CS-mount			
	Interface connector	Video output	DVI Output HDMI connector, SDI Output BNC connector		
		Power input	12V power jack		
		External control	3.5Φ stereo jack with SW board	3.5Φ stereo jack with SW board, SM06B-SRSS (JST) 6-pin connector header for up to nine external switch connectivity Functions are in the list of 2.2 The camera control functions	
		Communication	3.5Φ stereo jack		
	Button	Primary SW Initial press button function: push to set white balance Initial hold button function: Auto white balance (Function is selectable via the UART communication)			
	Weight	Approximate 120g	Approximate 50g		
	Environmental specifications	Operational temperature	0 to +40 deg. C		
Storage temperature		-30 to +65 deg. C			
Vibration		20Hz to 200Hz to 20Hz (5min./cycle), acceleration: 10G, 30 min., XYZ each directions	-		
Shock		Acceleration: 38G, half amplitude 6ms, 3 times XYZ each directions	-		
Standard compliancy		EMS: EN61000-6-2, EMI: 55011			
RoHS		RoHS compliance			

B. Spectral Sensitivity Characteristics

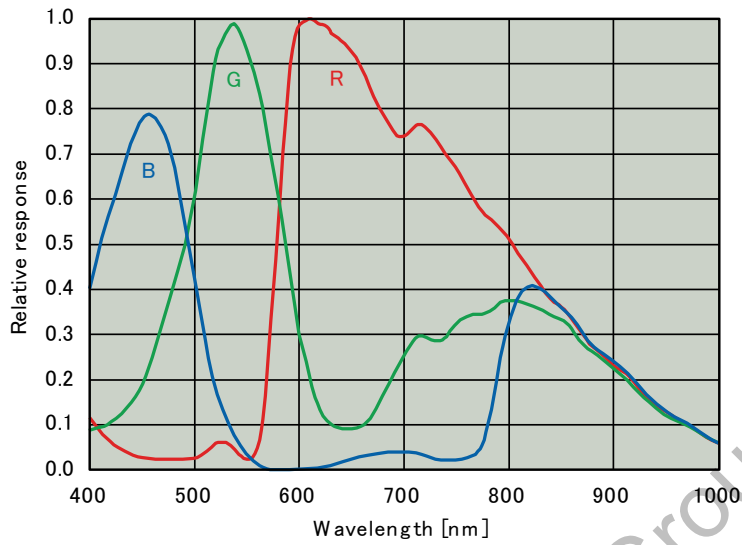

C. Camera Operations (TBD)

Aegis Electronic Group
www.aegiselect.com

D. Shutter Setting

Formula for the exposure moment

Setting value is 0 to 63:

$$\text{Exposure time (seconds)} = \left(\frac{Vline \times Hclk}{128} - \frac{Vline \times Hclk \times \text{Setting value}}{128} \right) \times \frac{1}{Fclk}$$

Setting value is 64 to 127:

$$\text{Exposure time (seconds)} = \left(\frac{Vline \times Hclk}{2} - \frac{Vline \times Hclk \times (\text{Setting value} - 64)}{256} \right) \times \frac{1}{Fclk}$$

Setting value is 128 to 191:

$$\text{Exposure time (seconds)} = \left(\frac{Vline \times Hclk}{4} - \frac{Vline \times Hclk \times (\text{Setting value} - 128)}{512} \right) \times \frac{1}{Fclk}$$

Setting value is 192 to 255:

$$\text{Exposure time (seconds)} = \left(\frac{Vline \times Hclk}{8} - \frac{Vline \times Hclk \times (\text{Setting value} - 192)}{1,024} \right) \times \frac{1}{Fclk}$$

Setting value is 256 to 319:

$$\text{Exposure time (seconds)} = \left(\frac{Vline \times Hclk}{16} - \frac{Vline \times Hclk \times (\text{Setting value} - 256)}{2,048} \right) \times \frac{1}{Fclk}$$

Setting value is 320 to 383:

$$\text{Exposure time (seconds)} = \left(\frac{Vline \times Hclk}{32} - \frac{Vline \times Hclk \times (\text{Setting value} - 320)}{4,096} \right) \times \frac{1}{Fclk}$$

Setting value is 384 to 447:

$$\text{Exposure time (seconds)} = \left(\frac{Vline \times Hclk}{64} - \frac{Vline \times Hclk \times (\text{Setting value} - 384)}{8,192} \right) \times \frac{1}{Fclk}$$

Setting value is 448 to 511:

$$\text{Exposure time (seconds)} = \left(\frac{Vline \times Hclk}{128} - \frac{Vline \times Hclk \times (\text{Setting value} - 448)}{16,384} \right) \times \frac{1}{Fclk}$$

Setting value is 512 to 575:

$$\text{Exposure time (seconds)} = \left(\frac{Vline \times Hclk}{256} - \frac{Vline \times Hclk \times (\text{Setting value} - 512)}{32,768} \right) \times \frac{1}{Fclk}$$

Setting value is 576 to 639:

$$\text{Exposure time (seconds)} = \left(\frac{Vline \times Hclk}{512} - \frac{Vline \times Hclk \times (\text{Setting value} - 576)}{65,536} \right) \times \frac{1}{Fclk}$$

Setting value is 640 to 699:

$$\text{Exposure time (seconds)} = \left(\frac{Vline \times Hclk}{1,024} - \frac{Vline \times Hclk \times (\text{Setting value} - 640)}{131,072} \right) \times \frac{1}{Fclk}$$

Vline: Number of lines for 1V = 750
 Fclk: Clock frequency = 74.25 MHz = 74,250,000
 Hclk: Number of clocks for 1H = 1,650 (60 or 59.94 Hz) or 1,980 (50 Hz)

Exposure time example:

720p-60Hz, 720p-59.94Hz operations

Value	High speed shutter	
0	16.7ms	1/60s
64	8.33ms	1/120s
128	4.17ms	1/240s
192	2.08ms	1/480s
256	1.04ms	1/960s
320	520.8us	1/1,920s
384	260.4us	1/3,840s
448	130.2us	1/7,680s
512	65.1us	1/15,360s
576	32.6us	1/30,720s
640	16.3us	1/61,440s
699	10.0us	1/100,000s

720p-50Hz operations

Value	High speed shutter	
0	20.0ms	1/50s
64	10.0ms	1/100s
128	5.00ms	1/200s
192	2.50ms	1/400s
256	1.25ms	1/800s
320	625.0us	1/1,600s
384	312.5us	1/3,200s
448	156.25us	1/6,400s
512	78.13us	1/12,800s
576	39.06us	1/25,600s
640	19.53us	1/51,200s
699	12.0us	1/83,947s

E. Camera Control Functions

Functin
1 Display Menu
2 DSP preset (+)
3 DSP preset (-)
4 Contrast (+)
5 Contrast (-)
6 Shadow mask shading level (+)
7 Shadow mask shading level (-)
8 Shadow mask top (+)
9 Shadow mask top (-)
10 Shadow mask bottom (+)
11 Shadow mask bottom (-)
12 Shadow mask top / bottom (+)
13 Shadow mask top / bottom (-)
14 Shadow mask left (+)
15 Shadow mask left (-)
16 Shadow mask right (+)
17 Shadow mask right (-)
18 Shadow mask left / right (+)
19 Shadow mask left / right (-)
20 Horizontal line maker color (+)
21 Horizontal line maker color (-)
22 Horizontal line maker size (+)
23 Horizontal line maker size (-)
24 Horizontal line maker position (+)
25 Horizontal line maker position (-)
26 Vertical line maker color (+)
27 Vertical line maker color (-)
28 Vertical line maker size (+)
29 Vertical line maker size (-)
30 Vertical line maker position (+)
31 Vertical line maker position (-)
32 Horizontal mirror OFF
33 Horizontal mirror ON
34 Horizontal mirror ON/OFF change
35 Manual white balance
36 Auto white balance
37 Push to set white balance
38 Auto/manual white balance change
39 ALC OFF
40 ALC ON
41 ALC ON/OFF change
42 Fixed shutter
43 Auto shutter
44 Auto/fixe shutter change
45 Fixed gain
46 AGC ON
47 Fixed gain/AGC change

Function
48 Undisplay maker (line maker and shadow mask)
49 Display maker (line maker and shadow mask)
50 Display/Undisplay maker (line maker and shadow mask)
51 Undisplay line maker
52 Display line maker
53 Display/Undisplay line maker
54 Undisplay shadow mask
55 Display shadow mask
56 Display/Undisplay shadow mask
57 Save to EEPROM (Horizontal mirror OFF)
58 Save to EEPROM (Horizontal mirror ON)
59 Save to EEPROM (Horizontal mirror ON/OFF change)
60 Save to EEPROM (Manual white balance)
61 Save to EEPROM (Auto white balance)
62 Save to EEPROM (Push to set white balance)
63 Save to EEPROM (Auto/manual white balance change)
64 Save to EEPROM (Undisplay maker (line maker and shadow mask))
65 Save to EEPROM (Display maker (line maker and shadow mask))
66 Save to EEPROM (Display/Undisplay maker (line maker and shadow mask))
67 Save to EEPROM (Undisplay line maker)
68 Save to EEPROM (Display line maker)
69 Save to EEPROM (Display/Undisplay line maker)
70 Save to EEPROM (Undisplay shadow mask)
71 Save to EEPROM (Display shadow mask)
72 Save to EEPROM (Display/Undisplay shadow mask)
73 Horizontal mirror ON/OFF change (Select: ON, unselect: OFF)
74 Auto/manual white balance change (Select: Auto, unselect: manual)
75 Display/Undisplay maker (line maker and shadow mask) (Select: Display, unselect: undisplay)
76 Display/Undisplay line maker (Select: Display, unselect: undisplay)
77 Display/Undisplay shadow mask (Select: Display, unselect: undisplay)

F. External Control Board Circuits

SW Board Circuits for 3.5 Φ stereo jack (External SW)

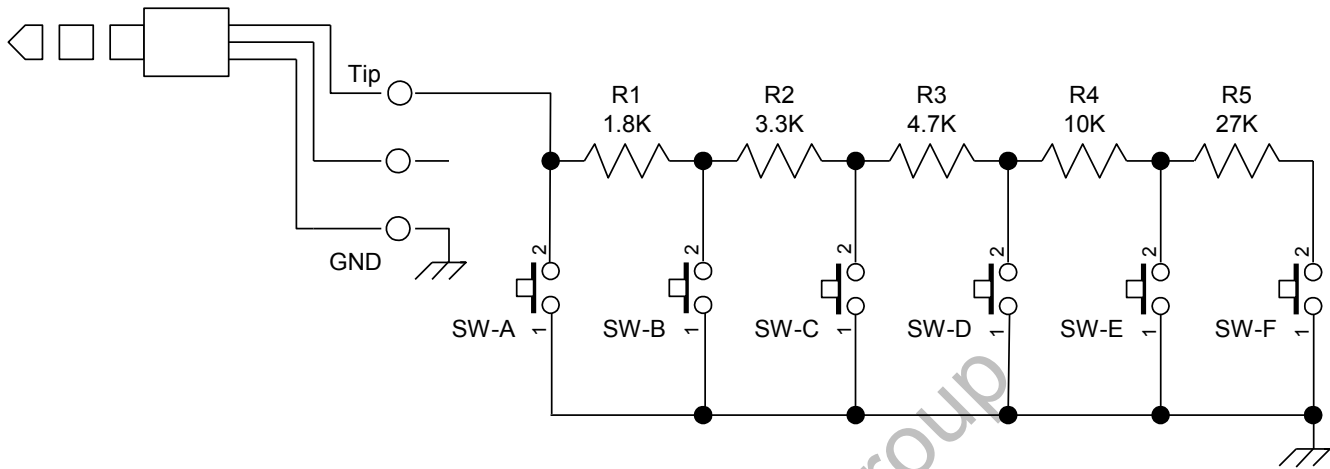

SW Board Circuits for the SM06B-SRSS-TB (JST) on Board Type (Board SW)

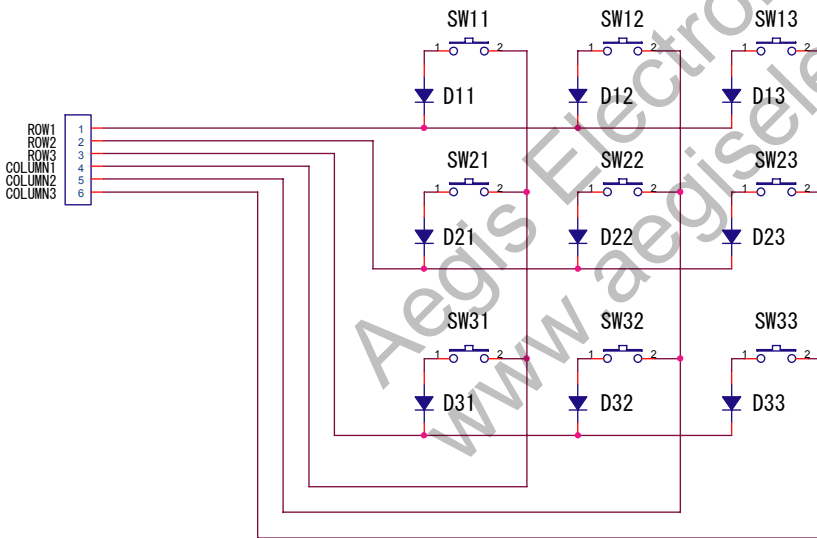

III. Dimensions

A. STC-HD93DV

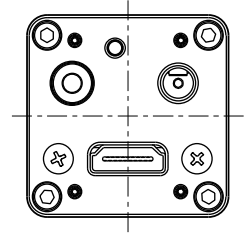
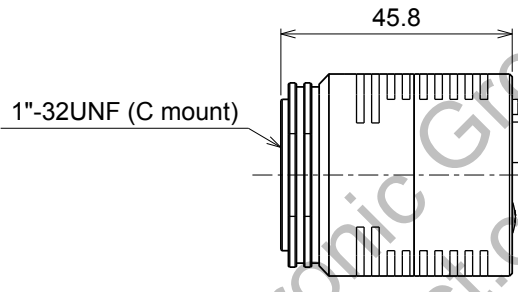
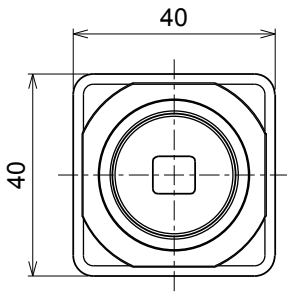
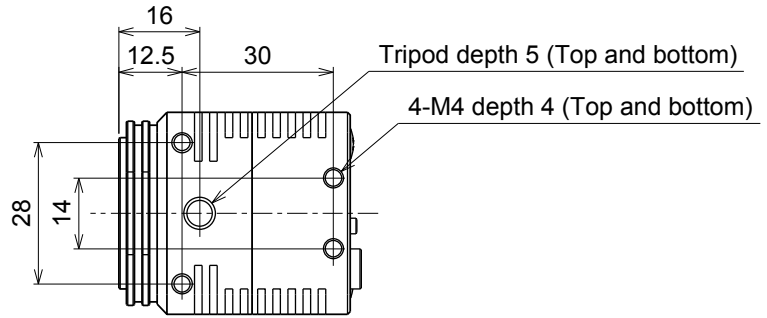

Aegis Electronic Group
www.aegiselect.com

Unit: mm

B. STC-HD93DV-B

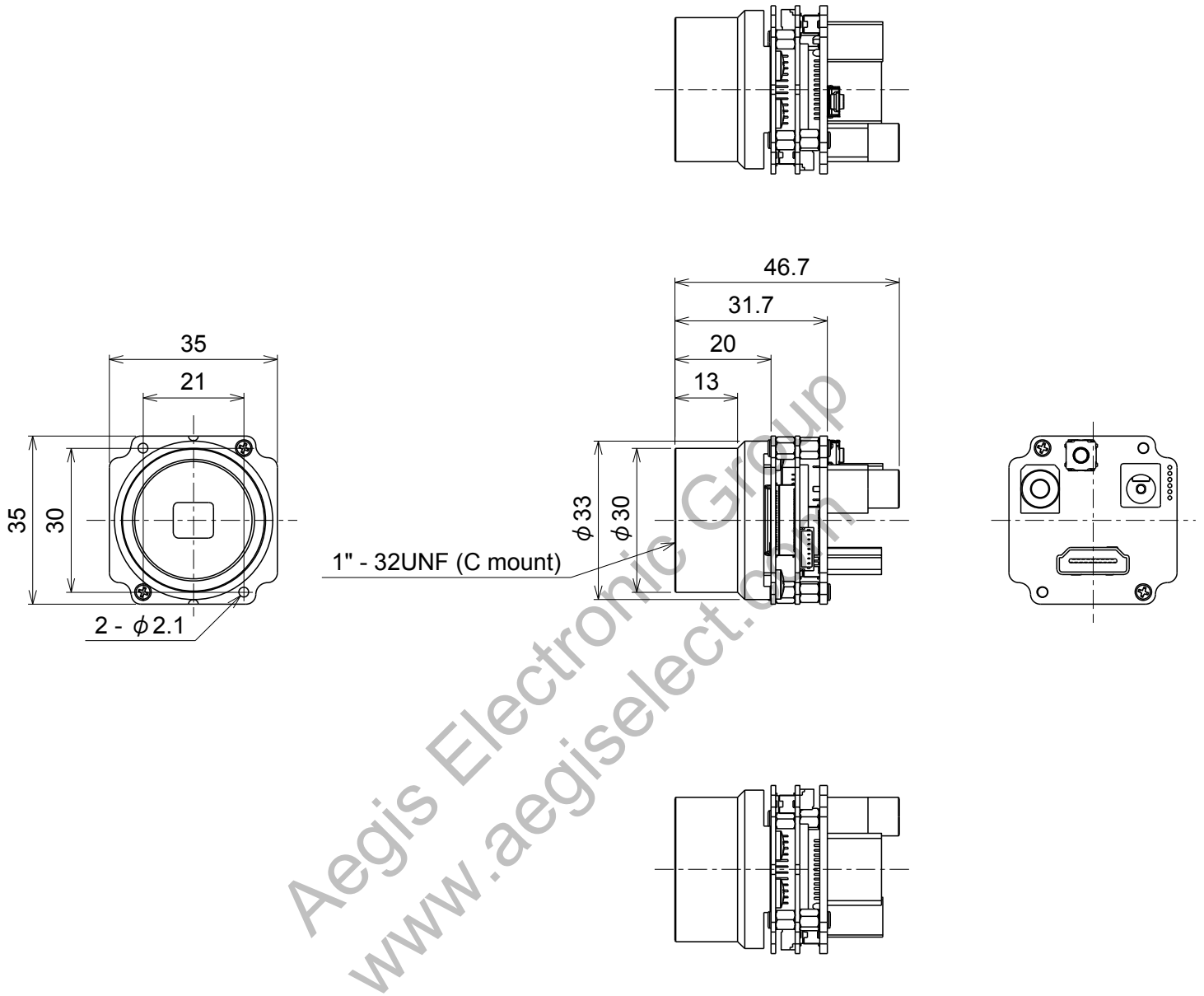

C. STC-HD93DV-CS

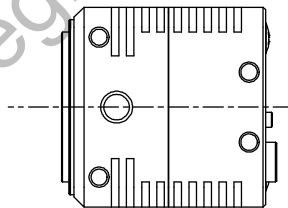
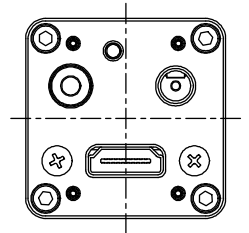
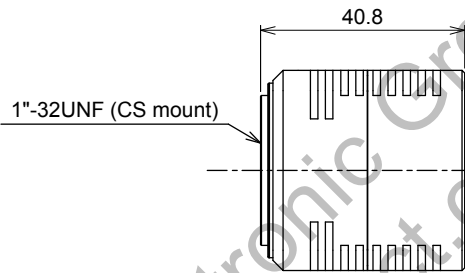
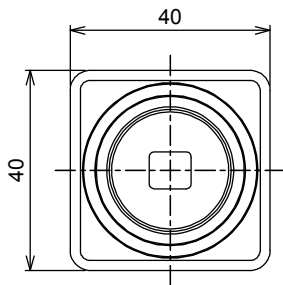
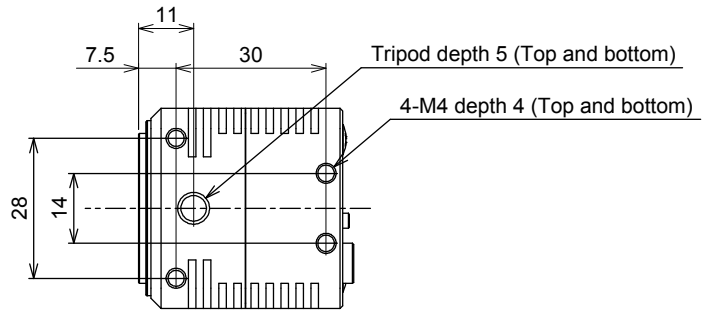

Unit: mm

D. STC-HD93DV-BCS

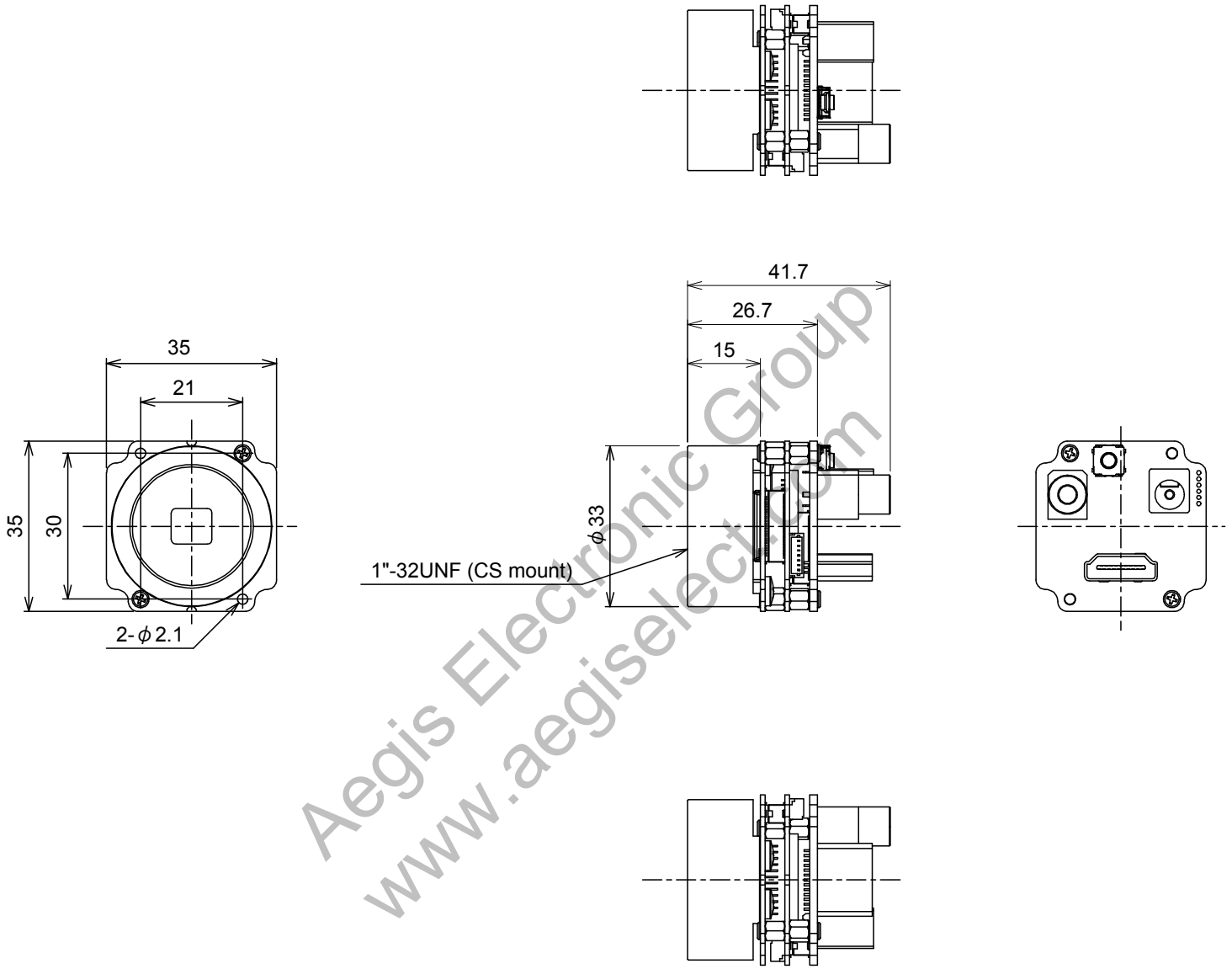

Unit: mm

E. STC-HD93DV-BHS

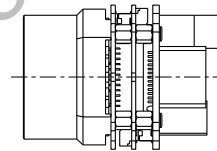
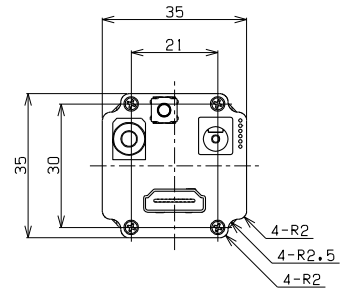
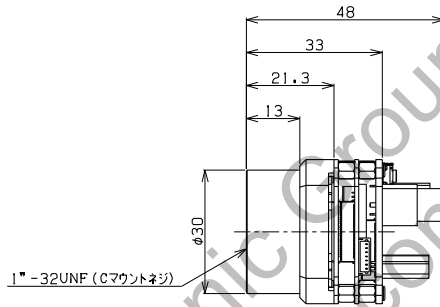
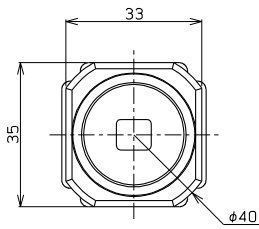
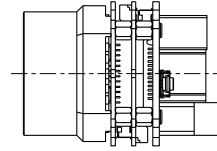
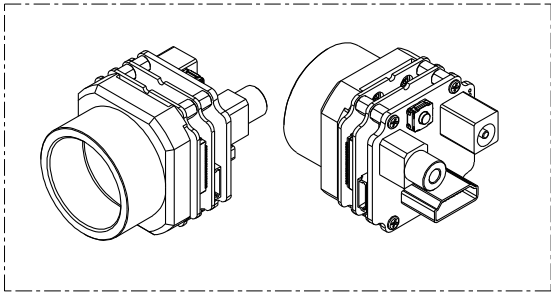

Aegis Electronic Group
www.aegiselect.com

Unit: mm

F. STC-HD93SDI

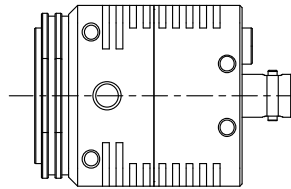
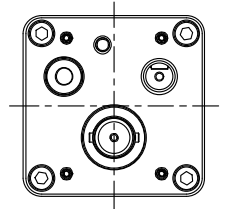
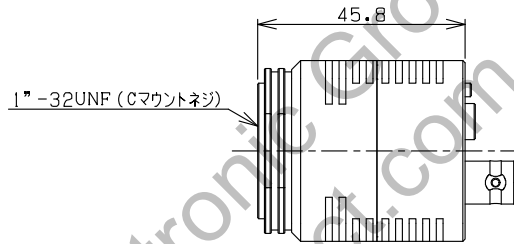
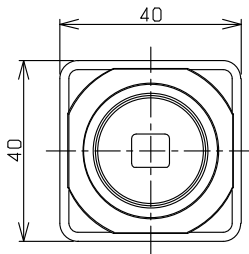
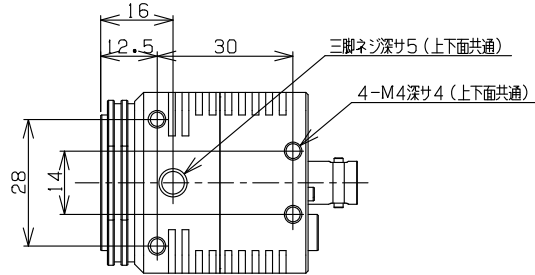
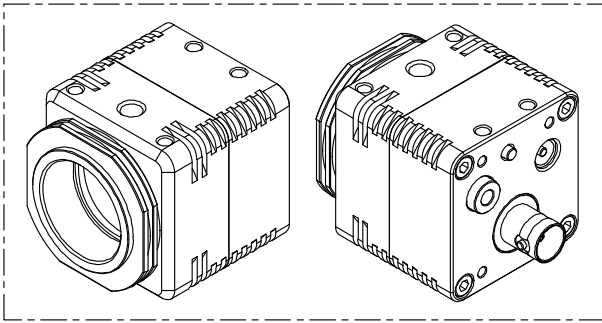

Unit: mm

G. STC-HD93SDI-B

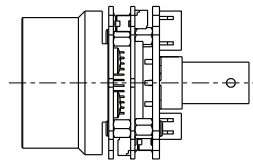
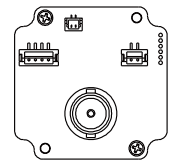
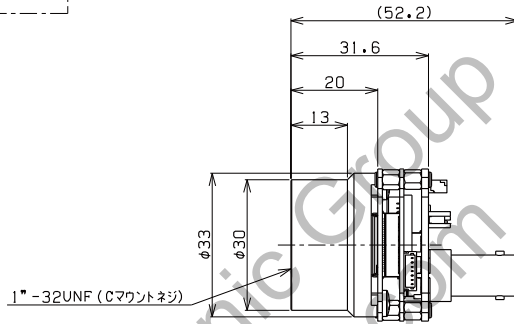
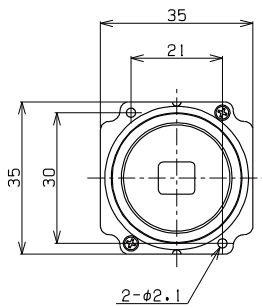
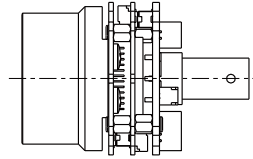
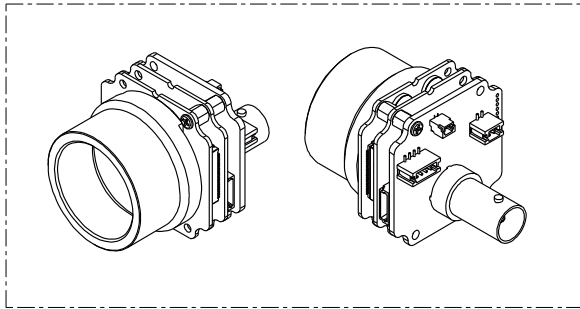

Unit: mm

H. STC-HD93SDI-CS

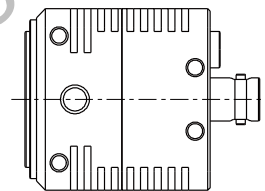
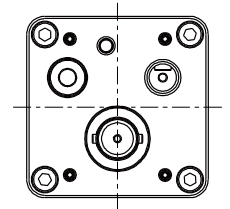
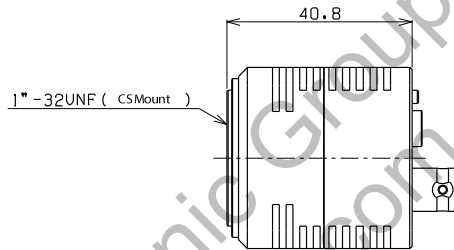
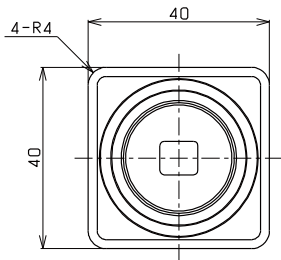
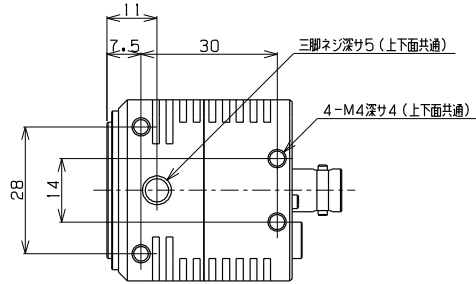
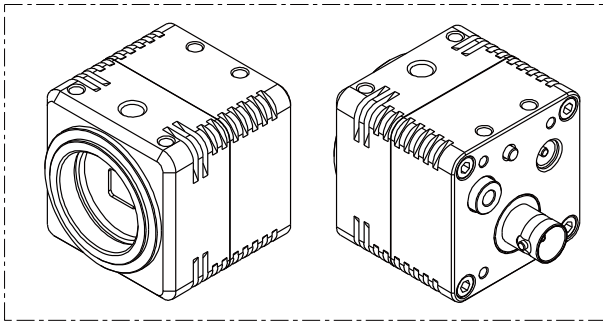

Unit: mm

I. STC-HD93SDI-BHS

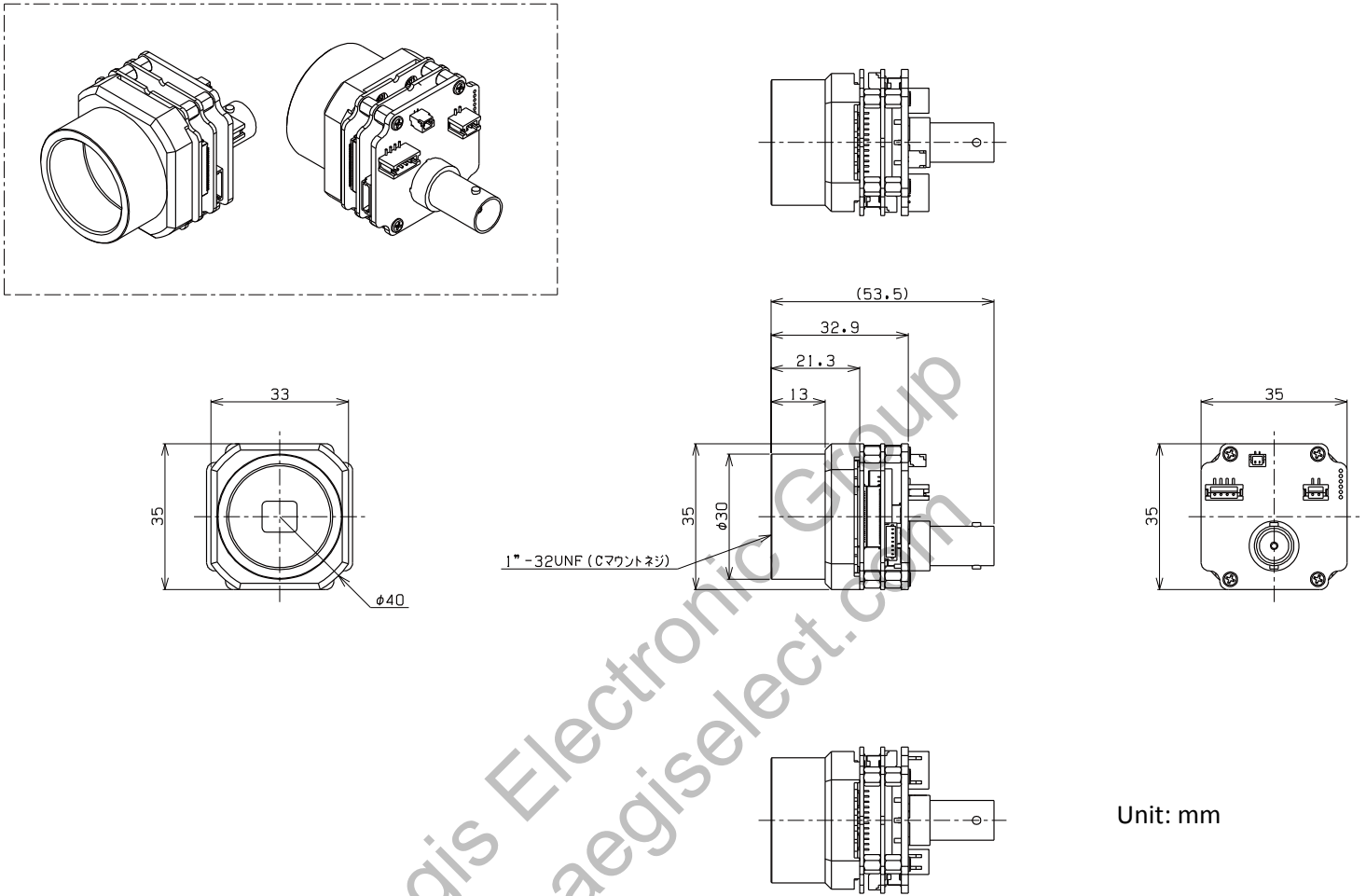

Revisions

Rev	Date	Changes	Note
0.00-2	2013/4/2	New document	

Aegis Electronic Group
www.aegiselect.com