

# E3Z3915CS-MPWIR

**3X 3.9mm-10mm F1.5 Day & Night  
for 1/1.8 type Megapixel Cameras, Vari-focal Manual Iris  
CS-Mount**

Model No.		E3Z3915CS-MPWIR		Effective	Front	$\phi$ 25.0mm	
Focal Length		3.9mm - 10mm		Lens Aperture	Rear	$\phi$ 10.0mm	
Max. Aperture Ratio		1:1.5		Back Focal Length	Tele	8.5mm	
Max. Image Format		7.1mm x 5.4mm( $\phi$ 8.9mm)			Wide	8.5mm	
Operation Range	Iris	F1.5 - F16C		Flange Back Length		12.5mm	
	Focus	0.8m - Inf.		Mount		CS-Mount	
	Zoom	3.9mm - 10mm		Filter Size		-	
Control	Iris	Manual		Dimensions		$\phi$ 40 mm x 49 mm x 59 mm	
	Focus	Manual		Weight		69g	
	Zoom	Manual					
Angle of View	D	1/1.8 type	144.1° - 52.9°	1/2 type	124.8° - 47.5°	1/3 type	89.3° - 35.5°
	H		108.1° - 42.1°		96.0° - 37.9°		70.2° - 28.4°
	V		79.7° - 32.0°		70.2° - 28.4°		52.1° - 21.3°
Operating Temperature		-20°C - +60°C					

## Dimensions

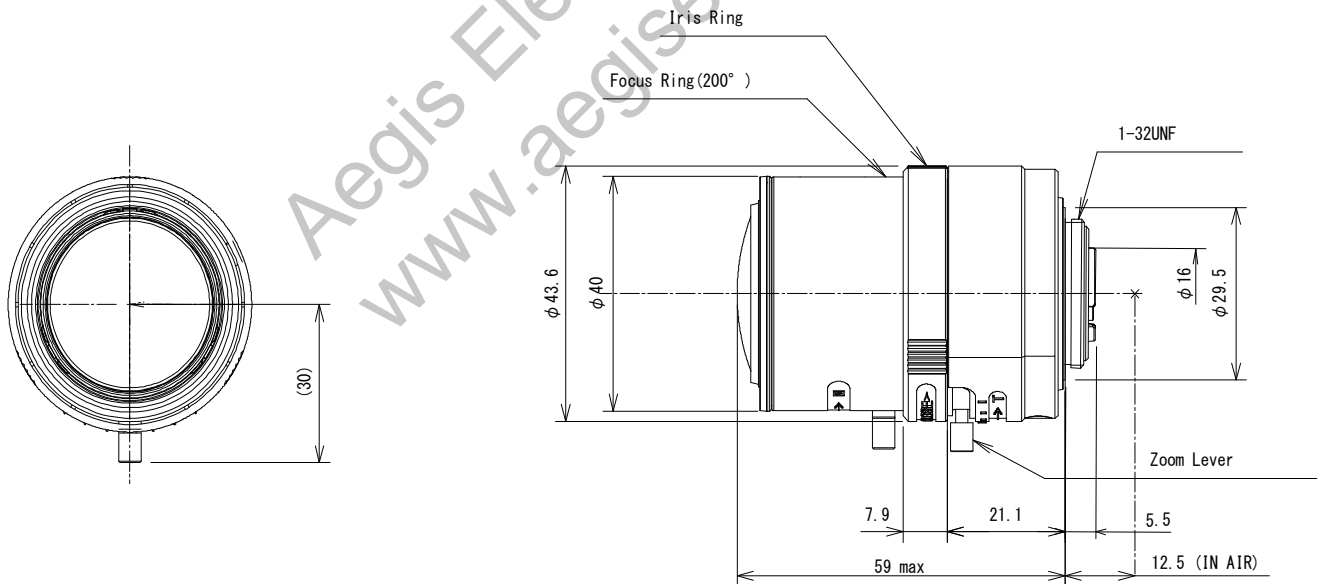

Unit : mm