

SENTECH**OMRON**

12 Meg CMOS Color / Monochrome Camera Link Camera

STC-CMC120APCL (12M Color)

STC-CMB120APCL (12M Monochrome)

Product Specifications and Users guide

Aegis Electronic Group, Inc.

 (888)687-6877
ELECTRONIC GROUP, INC
aegis-g2@aegiselect.com

OMRON SENTECH CO., LTD.

Table of Contents

1	OVERVIEW	5
1.1	FEATURES.....	5
1.2	NAMING METHOD.....	5
2	SPECIFICATIONS	6
2.1	ELECTRONIC SPECIFICATIONS / MECHANICAL SPECIFICATIONS / ENVIRONMENTAL SPECIFICATIONS	6
2.1.1	STC- CMC120APCL (Color) / STC- CMB120APCL (Monochrome).....	6
2.2	SPECTRAL SENSITIVITY CHARACTERISTICS	7
2.2.1	STC-CMC120APCL/ STC-CMB120APCL.....	7
2.3	CONNECTOR SPECIFICATIONS	8
2.3.1	Camera Link connectors:.....	8
2.4	POWER/IO CONNECTOR:	9
2.5	DIMENSIONS	12
3	CAMERA INSTALLATION	14
4	THE CAMERA OUTPUT TIMING CHARTS	15
4.1	THE HORIZONTAL TIMINGS (CMC120APCL).....	15
4.1.1	10 Taps (1X10-1Y) / Horizontal : 4,090 pixels	15
4.1.2	8 Taps (1X8-1Y) / Horizontal 4,096 pixels	17
4.1.3	4 Taps (1X4-1Y) / Horizontal : 4,096 pixels	19
4.1.4	3 Taps (1X3-1Y) / Horizontal 4,092 pixels	20
4.1.5	2 Taps (1X2-1Y) / Horizontal : 4,096 pixels	20
4.2	THE VERTICAL TIMINGS.....	21
4.3	FULL SCAN (TC-CMC120APCL / STC-CMB120APCL).....	21
4.4	AOI OUTPUT TIMING.....	22
4.5	CAMERA LINK BIT ASSIGNMENT.....	25
4.6	CAMERA LINK TAP GEOMETRY	29
4.6.1	10TAP (1X10-1Y).....	29
4.6.2	8TAP (1X8-1Y).....	29
4.6.3	4TAP (1X4-1Y).....	30
4.6.4	2TAP (1X2-1Y).....	30
4.7	BAYER PATTERN FOR COLOR MODEL (ONLY STC-CMC120APCL)	31
5	CAMERA FUNCTION MODES	32
5.1	NORMAL MODE.....	32
5.1.1	Normal mode (Electronic shutter)	32
5.2	PULSE WIDTH TRIGGER MODE.....	33
5.2.1	Pulse width trigger mode	33
5.2.2	Pulse Width Trigger mode (Exposure timing).....	33
5.3	EDGE PRESET TRIGGER MODE.....	
5.3.1	Edge Preset Trigger mode	
5.3.2	
5.3.3	Edge Preset Trigger mode (Exposure timing).....	
6	THE COMMUNICATION PROTOCOL SPECIFICAI	
6.1	THE COMMUNICATION METHOD	
6.2	THE COMMUNICATION SETTINGS	
6.3	THE COMMUNICATION FORMAT	
6.4	THE CAMERA CONTROL COMMANDS	
6.4.1	The camera commands list(Device Code:00H	
6.4.2	Description of the camera control commands	
6.4.3	Camera Control Command list (Device Code	

8	CONTROL SOFTWARE	54
8.1	SUMMARY.....	54
8.1.1	File.....	55
8.1.2	Comm.....	55
8.1.3	Mode.....	55
8.1.4	Help.....	56
8.2	SOFTWARE FUNCTION(STANDARD).....	56
8.2.1	Shutter.....	56
8.2.2	Mode.....	57
8.2.3	Gain.....	58
8.2.4	Serial Communication.....	58
8.2.5	Flip.....	58
8.2.6	Other.....	58
8.3	SOFTWARE FUNCTION (PARTIAL).....	59
8.4	SOFTWARE FUNCTION ADVANCED).....	59
8.5	SOFTWARE FUNCTION (HDR).....	59
8.6	SOFTWARE FUNCTION (SP PIN).....	59
9	ACTUAL CAMERA SETTING & TECHNICAL NOTES	60
9.1	USING THE TRIGGER SIGNAL THROUGH 6PIN.....	60
10	REVISION HISTORY	61

Aegis Electronic Group, Inc.

Aegis (888)687-6877
 ELECTRONIC GROUP, INC
 aegis-g2@aegiselect.com

Product Precautions

- Handle the camera with care. Do not abuse the camera. Avoid striking or shaking it. Improper handling or storage could damage the camera.
- Do not pull or damage the camera cable.
- During camera use, do not wrap the unit in any material. This will cause the internal temperature of the unit to increase.
- Do not expose the camera to moisture, or do not try to operate it in wet areas.
- Do not operate the camera beyond its temperature, humidity and power source ratings.
- While the camera is not being used, keep the lens or lens cap on the camera to prevent dust or contamination from getting in the CCD or filter area and scratching or damaging this area.
- Do not keep the camera under the following conditions:
 - In wet, moist, and high humidity areas
 - Under hot direct sunlight
 - In high temperature areas
 - Near an object that releases a strong magnetic or electric field
 - Areas with strong vibrations
- Apply the power that satisfies the requirements specified in this document to the camera.
- Use a soft cloth to clean the camera. Use pressured air spray to clean the surface of the glass. DO not scratch the surface of the glass.
- The camera is a general-purpose electronic device; using the camera for the equipment that may threaten human life or cause dangers to human bodies directly in case of failure or malfunction of the camera is not guaranteed. Use the camera for special purposes at your own risk.

Product Warranty

➤ **Product Warranty Period**

We set one year warranty period on the products at the date of delivery (In the case of normal circumstances).

We do not cover the warranty under below circumstances.

Failure caused by use of mishandle, illegal repairs and conversions

Failure caused by external shocks such as descendant.

Failure caused by fire/earthquake/lightning and other natural disasters and abnormal voltage.

➤ **Warranty Coverage**

We change the product or do repair for the defected camera in case of the failure is occurred by our company, And a warranty is limited for the single supply of delivered goods, but does not include failures caused by other delivered goods (without cameras or parts of cameras).

 (888)687-6877

ELECTRONIC GROUP, INC
aegis-g2@aegiselect.com

1 Overview

This document describes the specifications of the following cameras:

STC-CMC120APCL	(12M Color)
STC-CMB120APCL	(12M Monochrome)

1.1 Features

- 12M pixel (4096 x 3072)
- CMOS Sensor (Global Shutter)
- Camera Link (Deca, Full, Medium, Base Configuration)
- 10,8,4,3,2TAP
- PoCL

This Camera Link cameras have 12M pixel CMOS sensor. They support max frame rate 62.3fps on 12M pixel(8bit, 10TAP mode).

1.2 Naming Method

STC-CMx120APCL-x

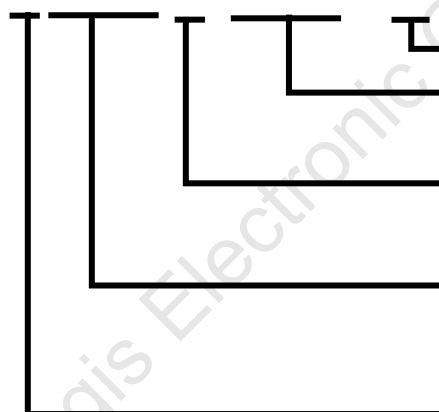

None: M42 Mount
F: F Mount
PCL:PoCL

Sensor Size
A: 1.76"

Resolution
120: 12M Pixel

C: Color
M:Monochrome

Figure 1. Naming Method

 (888)687-6877

ELECTRONIC GROUP, INC
aegis-g2@aegiselect.com

2 Specifications

2.1 Electronic specifications / Mechanical specifications / Environmental specifications

2.1.1 STC- CMC120APCL (Color) / STC- CMB120APCL (Monochrome)

Table 1. Specifications

Product		STC-CMC120APCL	STC-CMB120PCL	
Electronic specifications	Imager	1.76 " Type 12Meg color progressive CMOS (CMOSIS: CMV12000)	1.76" Type 12Meg monochrome progressive CMOS (CMOSIS: CMV12000)	
	Shutter	Global Shutter		
	Active picture elements	4090 (H) x 3072 (V): 10TAP 4096 (H) x 3072 (V): 8TAP,4TAP,2TAP 4092 (H) x 3072 (V): 3TAP		
	Chip size	22.5 × 16.9 mm		
	Cell size	5.5 (H) x 5.5 (V) μm		
	Scanning system	Progressive		
	Scanning method	Full scanning, Variable AOI	Full scanning, Variable AOI	
	Frame rate	62.3Hz(8bit 10TAP), 51.8Hz (8bit 8TAP), 25.9Hz (8/10/12bit 4TAP), 19.4Hz (8bit 3TAP), 12.9Hz (8/10/12bit 2TAP)		
	Vertical frequency of the Camera Link output			
	Pixel frequency of the Camera Link output	10TAP, 8TAP,4TAP,3TAP,2TAP: 85MHz or 42.5MHz (Selectable)		
	Noise level	8bit 10TAP	≤ 3.5 Digit (Gain 0 dB)	
	Minimum scene illumination	Typical 1.4 Lux at F2.25 (10TAP)	Typical 1.2 Lux at F2.25 (10TAP)	
	Sync. System	Internal		
	Video output	8bit: 10TAP, Full, Medium, Base Configuration 10bit: Medium, Base Configuration 12bit: Medium, Base Configuration		
	Shutter speed	8,4,2TAP : 41[us] to 207.736 [s] (LINE unit, Pulse Width Trigger), 42[us] to 16.777 [s] (us unit) 10TAP : 41[us] to 173.140[s] (LINE unit, Pulse Width Trigger), 42[us] to 16.777 [s] (us unit) 3TAP : 42[us] to 277.025[s] (LINE unit, Pulse Width Trigger), 43[us] to 16.777 [s] (us unit)		
	Digital gain	1 to x5		
	Gamma	1.0		
	Trigger Mode	Edge Preset Trigger(V Reset), Pulse Width Trigger (V Reset)		
	Power	Input voltage	12Vdc ± 10%	
		Consumption	10TAP, Full Configuration: Less than 7.0 W Base Configuration: Less than 5.2W	
Communication	RS232 via Camera Link connector			
Mechanical specifications	Dimensions	68 (W) x 68 (H) x 40 (D) mm (Excluding the connector)		
	Optical filter	No IR cut filter		
	Material	Aluminum alloy		
	Lens mount	M42 mount (F mount with adopter) FB = 10.0mm(in Air)		
	Interface connector	Camera Link connector: SDR connector x 2 Power/IO connector: HR10A-7R-6PB (Hirose) or equivalent		
	Weight			
Environmental specifications	Operational			
	Storage temperature			
	Vibration	20Hz to 200Hz to 20		
	Shock	Acceleratic		
	Standard compliancy			
RoHS				

(888)687-6877
ELECTRONIC GROUP, INC
aegis-g2@aegiselect.com

2.2 Spectral Sensitivity Characteristics

2.2.1 STC-CMC120APCL/ STC-CMB120APCL

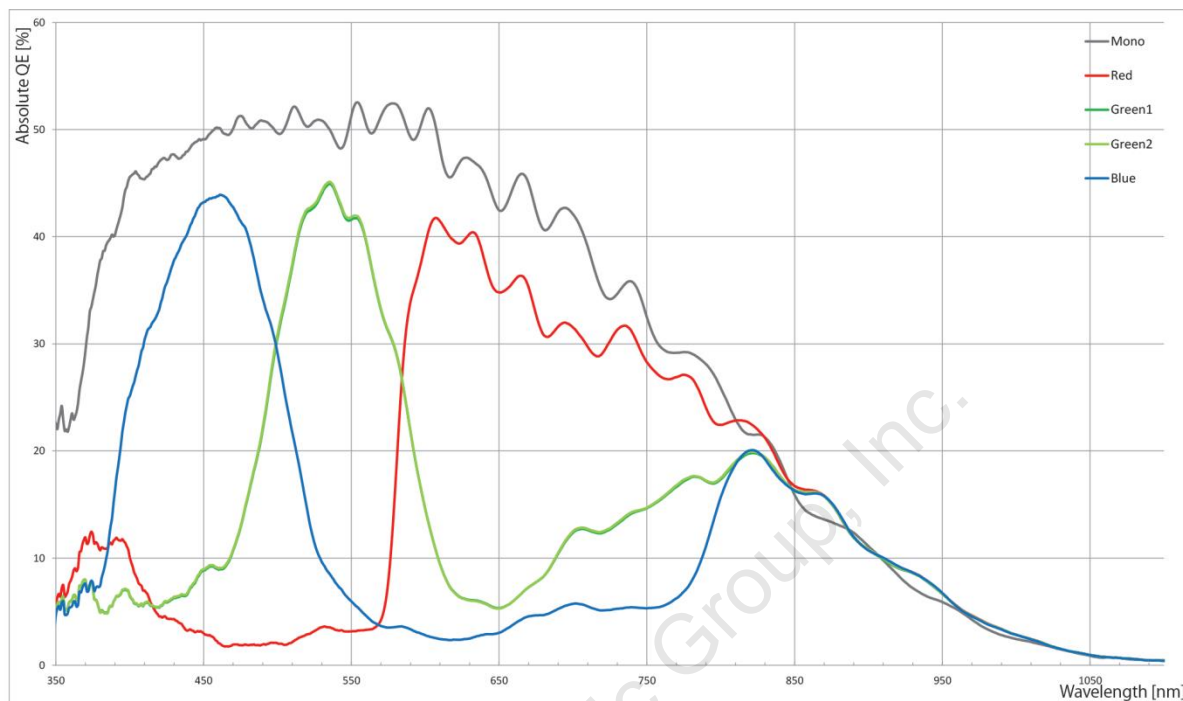

Figure 2. Spectral Sensitivity Characteristics

Aegis Electronic Group, Inc.

Aegis (888)687-6877
 ELECTRONIC GROUP, INC
 aegis-g2@aegiselect.com

2.3 Connector specifications

CH1:
26-pin SDR connector
(BaseCamera Link Connector)

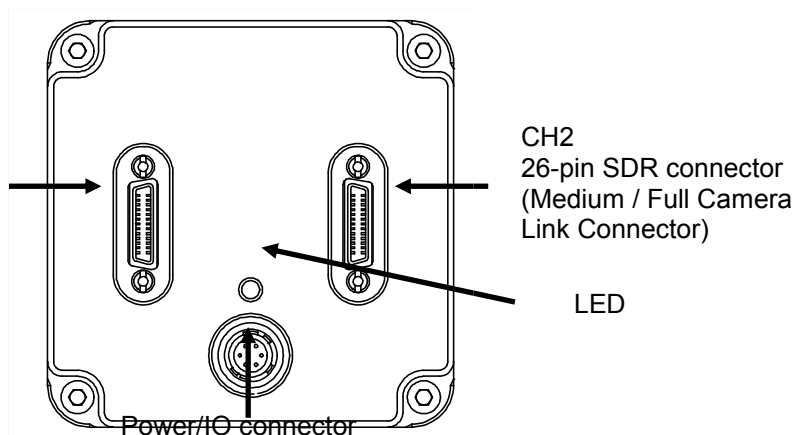

Figure 3. Back View

2.3.1 Camera Link connectors:

SDR(3M) equivalent x 2

(CAUTION)

This product is PoCL type.

When the frame grabber board and the cable are applicable for the PoCL, the frame grabber board supplies the power to the camera. In this case, please DO NOT supply the power from the Power/IO connector.

Pin assignment

Table 2. CN1:Base Camera Link Connector

Pin No.	Signal Name	Pin No.	Signal Name
1	+12V	14	GND
2	X0-	15	X0+
3	X1-	16	X1+
4	X2-	17	X2+
5	Xclk-	18	Xclk+
6	X3-	19	X3+
7	SerTC+	20	SerTC-
8	SerTFG-	21	SerTFG+
9	CC1- (TRG)	22	CC1+ (TRG)
10	CC2+	23	CC2-
11	CC3-	24	CC3+
12	CC4+	25	CC4-
13	GND	26	+12V

CN2:Medium/Full Camera Link Connector

Pin No.	Signal Name	Pin No.	Signal Name
1	+12V	14	GND
2	Y0-	15	Y0+
3	Y1-	16	Y1+
4	Y2-	17	Y2+
5	Yclk-	18	Yclk+
6	Y3-	19	Y3+
7	100Ω	20	100Ω
8	Z0-	21	Z0+

Aegis (888)687-6877
ELECTRONIC GROUP, INC

aegis-g2@aegiselect.com

2.4 Power/IO connector:

HR10A-7R-6PB (Hirose) or equivalent.

This connector is for 12Vdc power input and the input and output signals.

The trigger input and sync input /output signals can be assigned through the camera setting communication.

Pin assignment

Table 3. Pin assignment

Pin No	Signal Name	IN/OUT	Voltage		
				LowVoltage	HighVoltage
1	GND	IN	0V		
2	SP-4	IN	0 ~ +0.99V	+2.3 ~ +3.6V	
		OUT	0V	+3.3V	
3	SP-3	IN	0 ~ +0.99V	+2.3 ~ +3.6V	
		OUT	0V	+3.3V	
4	SP-2	IN	0 ~ +0.99V	+2.3 ~ +3.6V	
		OUT	0V	+3.3V	
5	SP-1	IN	0 ~ +0.99V	+2.3 ~ +3.6V	
		OUT	0V	+3.3V	
6	+12Vdc	IN	+12Vdc		

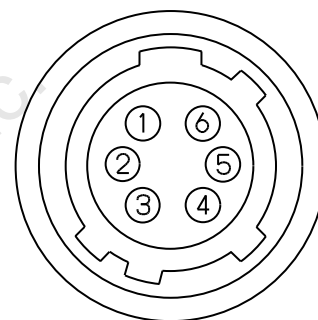

(Note 1)

Trigger input signal can be assigned either on Camera Link connector (CC1) or on the No. 2 pin of the power/IO connector through the camera setting communication.

As for the actual method of hardware trigger, please refer to the [Using the Trigger Signal through 6pin.](#)

Input Signal Circuit

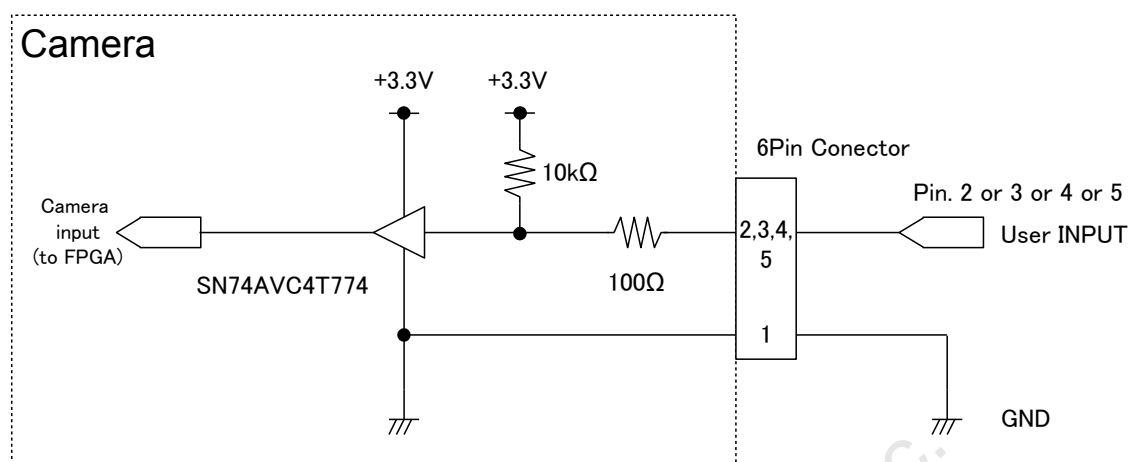

Figure 4. Input Signal Circuit

Input Signal Circuit Example

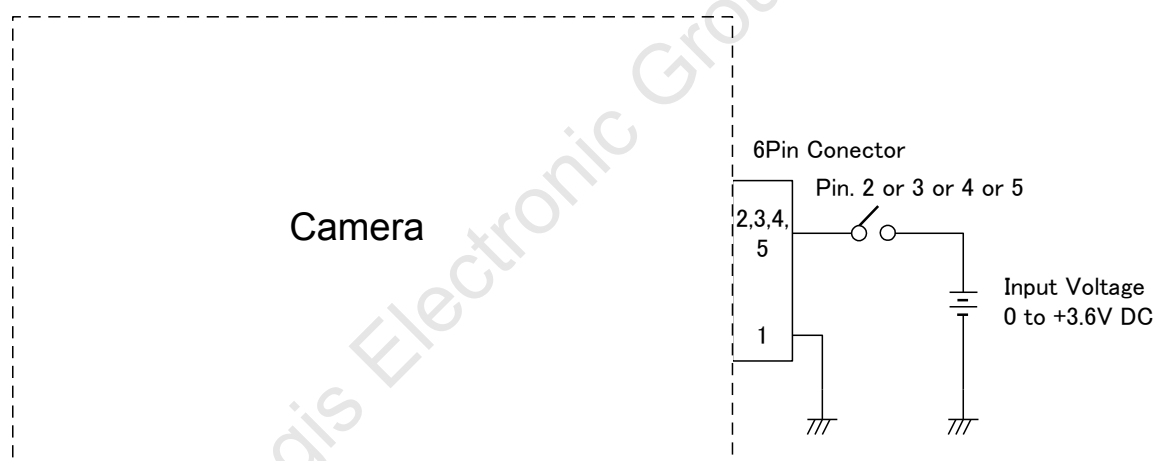

Figure 5. Input Signal Circuit Example

(888)687-6877
 ELECTRONIC GROUP, INC
 aegis-g2@aegiselect.com

Output Signal Circuit/ Example

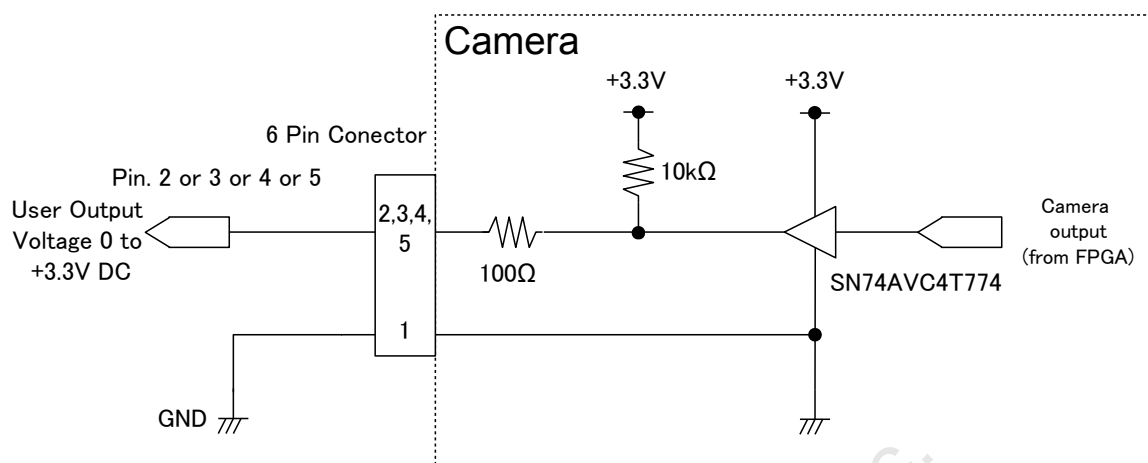

Figure 6. Output Signal Circuit Example

LED information

Table 4. LEC Information

Mode setting	LED
D9H.0 = 1	OFF
Trigger mode	On 1 second then Off 1 second (repeatedly)
Free run	ON

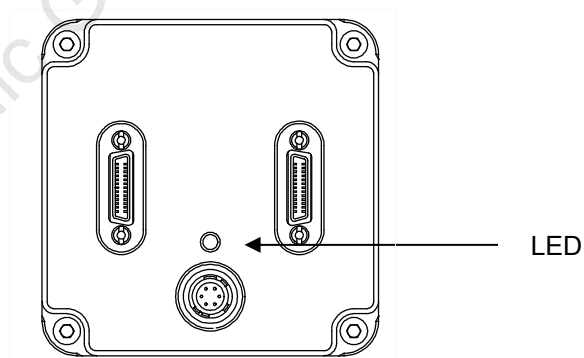

Figure 7. LED Location

Aegis (888)687-6877
ELECTRONIC GROUP, INC
aegis-g2@aegiselect.com

2.5 Dimensions

M42 Mount Model

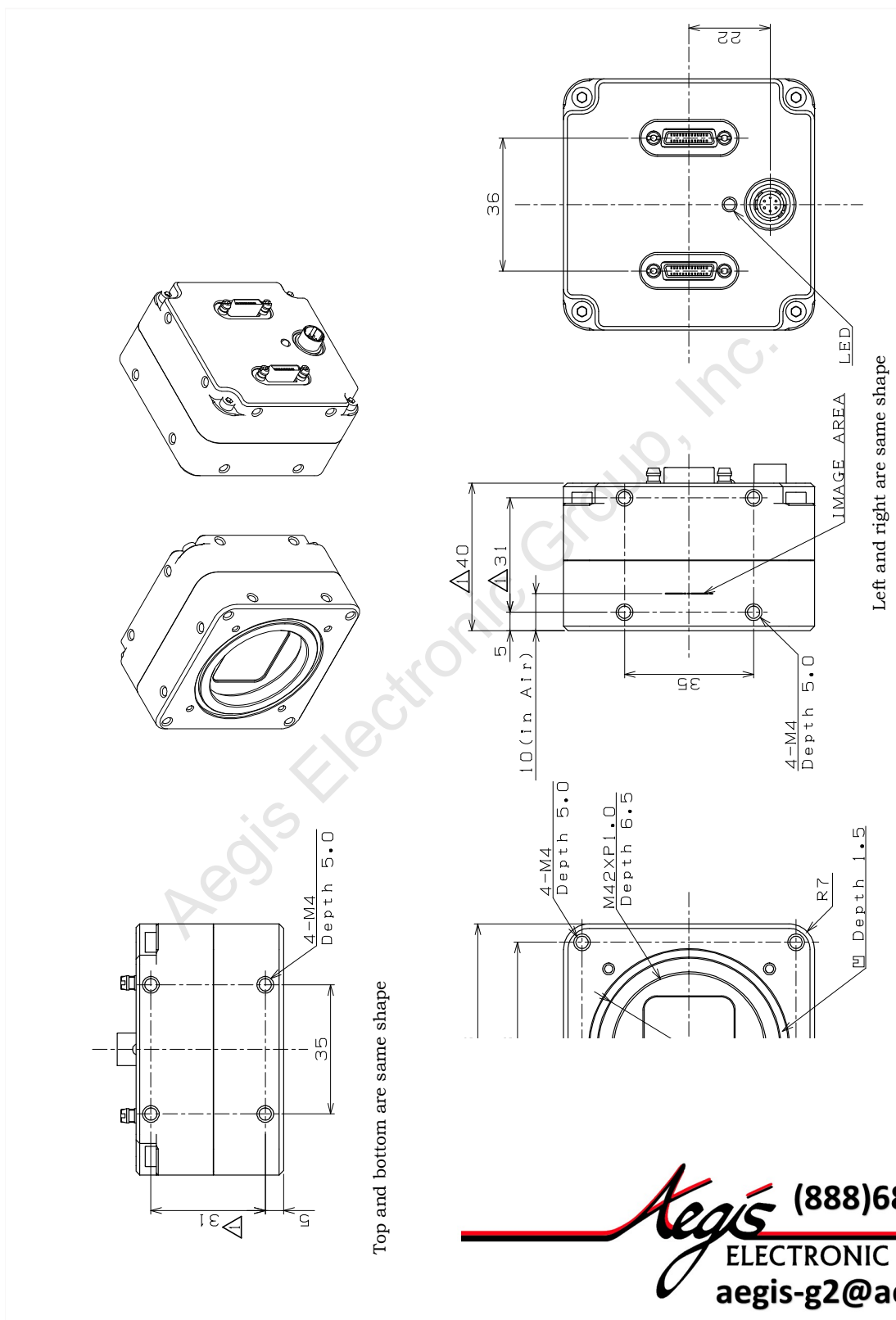

Figure 8. 1

Aegis (888)687-6877
 ELECTRONIC GROUP, INC
 aegis-g2@aegiselect.com

F Mount Model

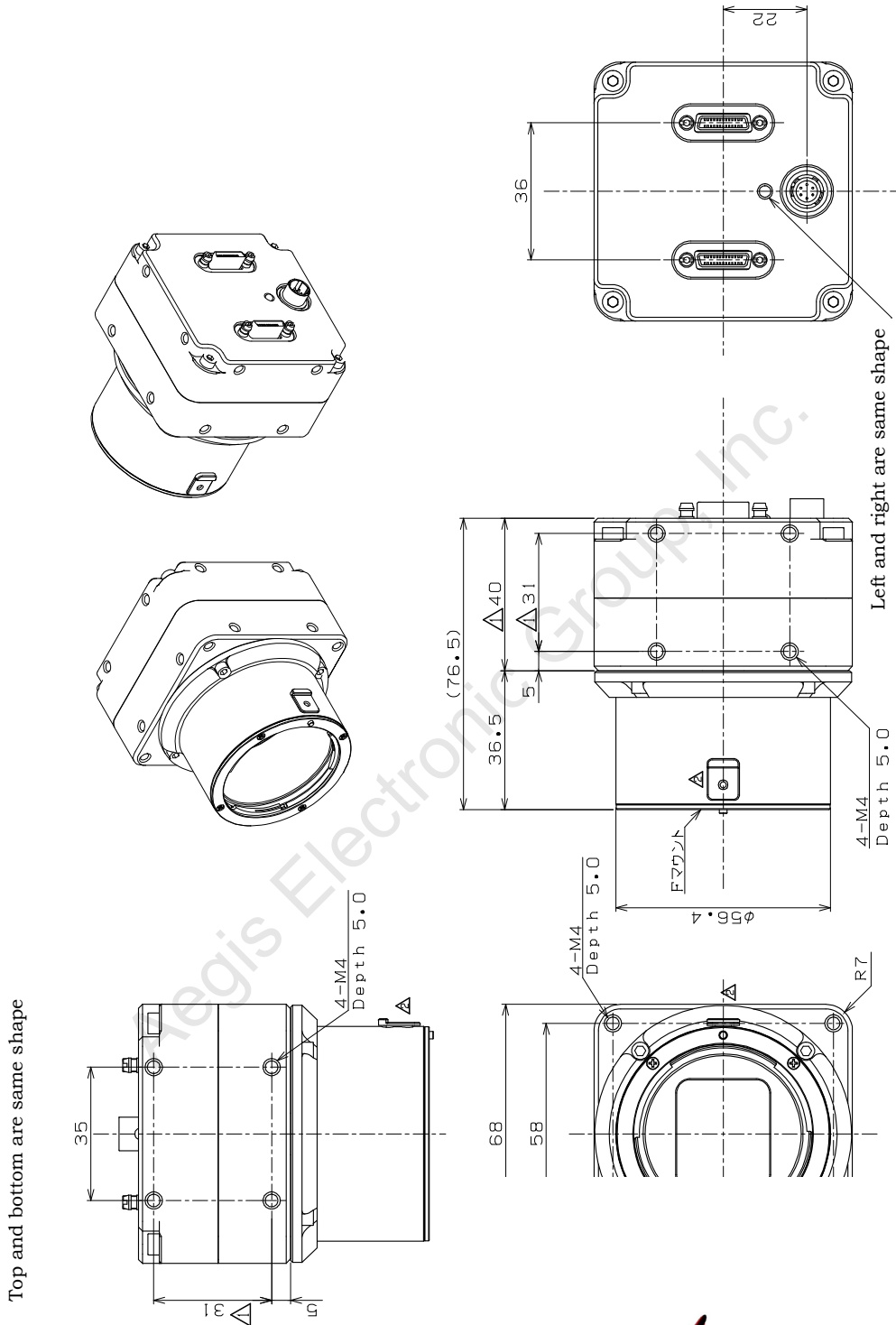

Figure 9.

Aegis (888)687-6877
 ELECTRONIC GROUP, INC
 aegis-g2@aegiselect.com

3 Camera Installation

For the installation of this camera, these equipment as bellow are required.

- Control software or Serial communication software to access the camera register.
As for using the software, please refer to [another chapter](#).

CONTROL Software. As for accessing the register, please refer to the **6.THE COMMUNICATION PROTOCOL SPECIFICATIONS**.

- Camera Link Cable x 2 (SDR Connector : Camera side)
When using on Full Configuration, please use the cable that has qualification.
- Frame Graber should support **Full, Medium, Base Configuration**. When using the PoCL, Frame Graber should support PoCL.

Aegis Electronic Group, Inc.

 (888)687-6877
ELECTRONIC GROUP, INC
aegis-g2@aegiselect.com

4 The camera output timing charts

4.1 The horizontal timings (CMC120APCL)

As for the vertical timing, please refer to [The Vertical timings](#).
 Highs Speed Clock and Low Speed Clock are existed as Pixel Clock.

4.1.1 10 Taps (1X10-1Y) / Horizontal : 4,090 pixels

1 CLK = 11.764 nseconds (85MHz)

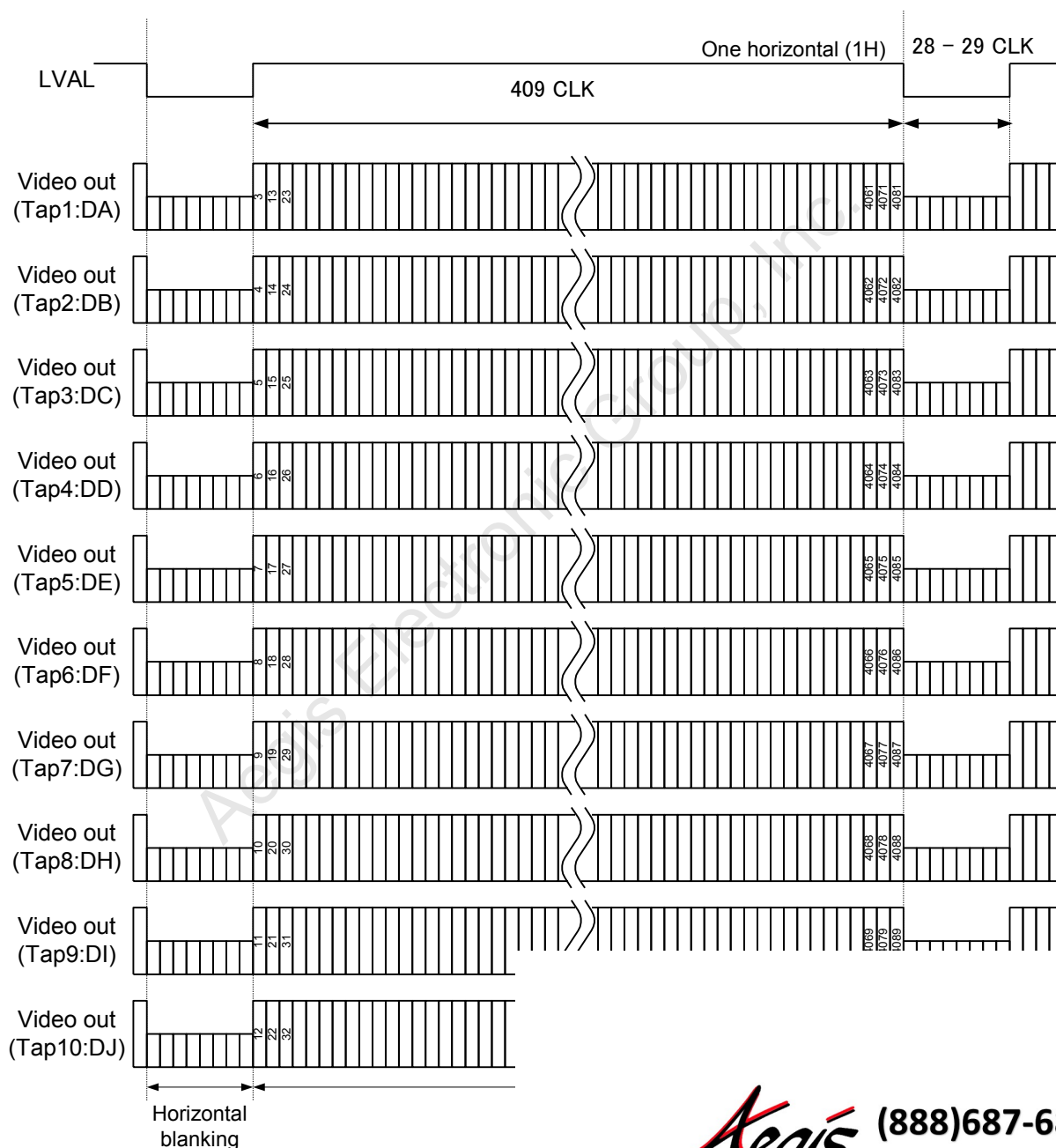

Aegis (888)687-6877
 ELECTRONIC GROUP, INC
 aegis-g2@aegiselect.com

The pixel order for the Image

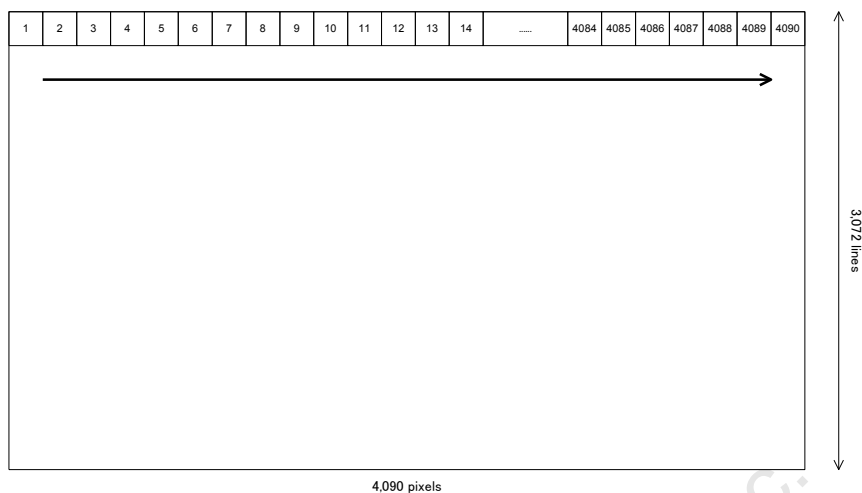

TAP1: DA output pixels	3	13	23	33	43	53	63	4021	4031	4041	4051	4061	4071	4081
TAP2: DB output pixels	14	24	34	44	54	64	74	4022	4032	4042	4052	4062	4072	4082
TAP3: DC output pixels	5	15	25	35	45	55	65	4023	4033	4043	4053	4063	4073	4083
TAP4: DD output pixels	6	16	26	36	46	56	66	4033	4034	4044	4054	4064	4074	4084
TAP5: DE output pixels	7	17	27	37	47	57	67	4025	4035	4045	4055	4065	4075	4085
TAP6: DF output pixels	8	18	28	38	48	58	68	4026	4036	4046	4056	4066	4076	4086
TAP7: DG output pixels	9	19	29	39	49	59	69	4027	4037	4047	4057	4067	4077	4087
TAP8: DH output pixels	10	20	30	40	50	60	70	4028	4038	4048	4058	4068	4078	4088
TAP9: DG output pixels	11	21	31	41	51	61	71	4029	4039	4049	4059	4069	4079	4089
TAP10: DH output pixels	12	22	32	42	52	62	72	4030	4040	4050	4060	4070	4080	4090

(888)687-6877
ELECTRONIC GROUP, INC
aegis-g2@aegiselect.com

4.1.2 8 Taps (1X8-1Y) / Horizontal 4,096 pixels

1 CLK = 11.764 nseconds(85MHz)
 1 CLK = 23.524 nseconds(42.5MHz)

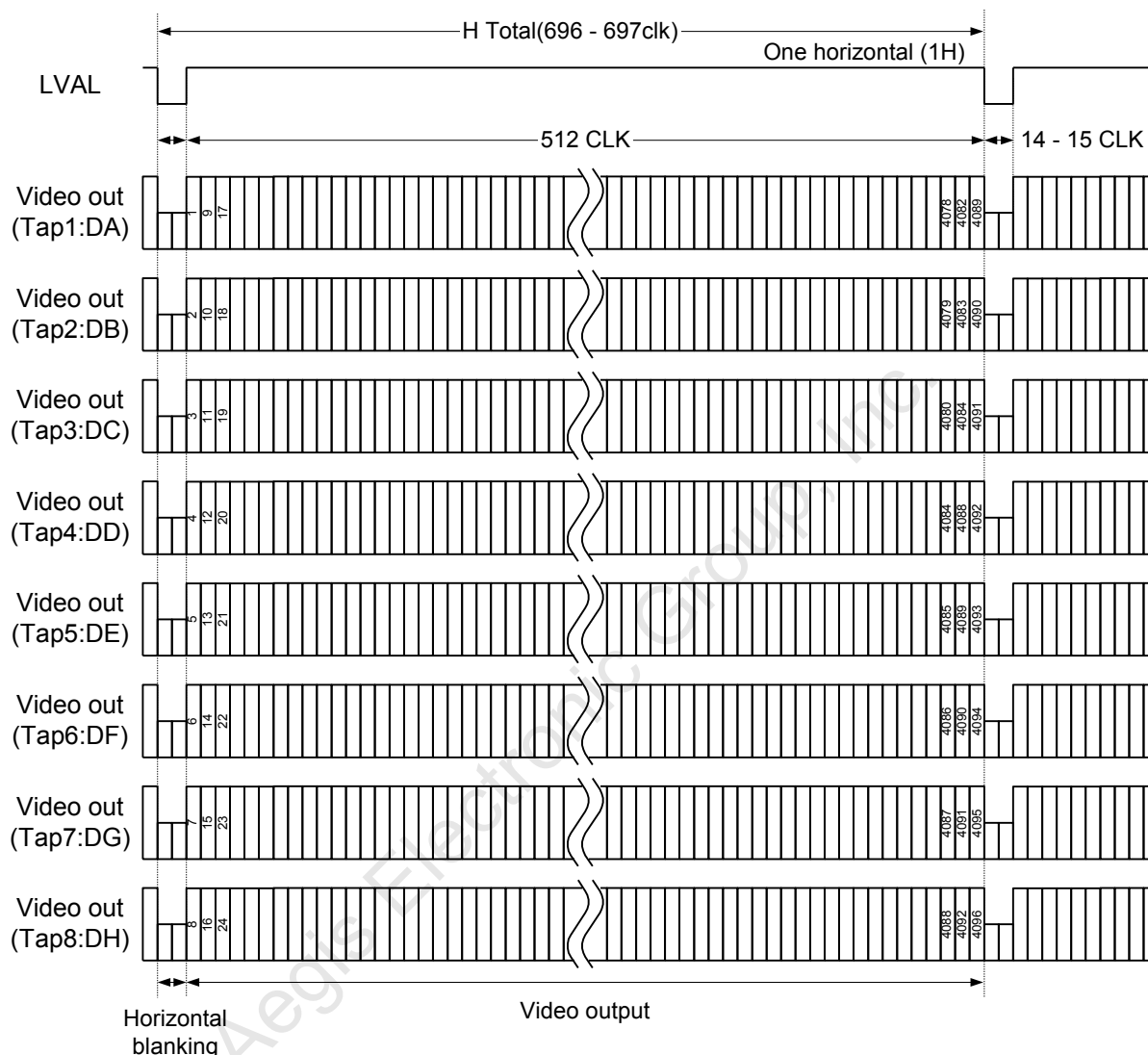

Aegis (888)687-6877
 ELECTRONIC GROUP, INC
aegis-g2@aegiselect.com

The pixel order for the Image

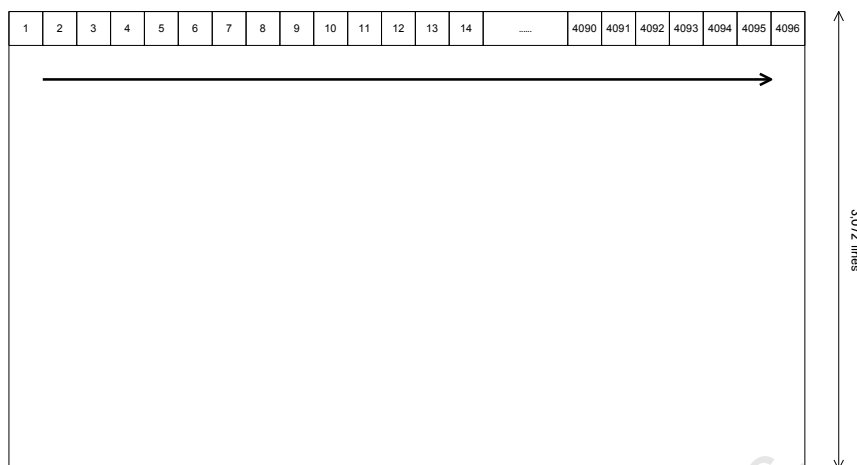

TAP1: DA output pixels	1	9	17	25	33	40	48	56	64	72	80	88	96	104	112	120	128	136	144	4041	4049	4057	4065	4073	4081	4089
TAP2: DB output pixels	2	10	18	26	34	42	50	58	66	74	82	90	98	106	114	122	130	138	146	4042	4050	4058	4066	4074	4082	4090
TAP3: DC output pixels	3	11	19	27	35	43	51	59	67	75	83	91	99	107	115	123	131	139	147	4043	4051	4059	4067	4075	4083	4091
TAP4: DD output pixels	4	12	20	28	36	44	52	60	68	76	84	92	100	108	116	124	132	140	148	4044	4052	4060	4068	4076	4084	4092
TAP5: DE output pixels	5	13	21	29	37	45	53	61	69	77	85	93	101	109	117	125	133	141	149	4045	4053	4061	4069	4077	4085	4093
TAP6: DF output pixels	6	14	22	30	38	46	54	62	70	78	86	94	102	110	118	126	134	142	150	4046	4054	4062	4070	4078	4086	4094
TAP7: DG output pixels	7	15	23	31	39	47	55	63	71	79	87	95	103	111	119	127	135	143	151	4047	4055	4063	4071	4079	4087	4095
TAP8: DH output pixels	8	16	24	32	40	48	56	64	72	80	88	96	104	112	120	128	136	144	152	4048	4056	4064	4072	4080	4088	4096

Aegis Electronic Group, Inc.



(888)687-6877
ELECTRONIC GROUP, INC
aegis-g2@aegiselect.com

4.1.3 4 Taps (1X4-1Y) / Horizontal : 4,096 pixels

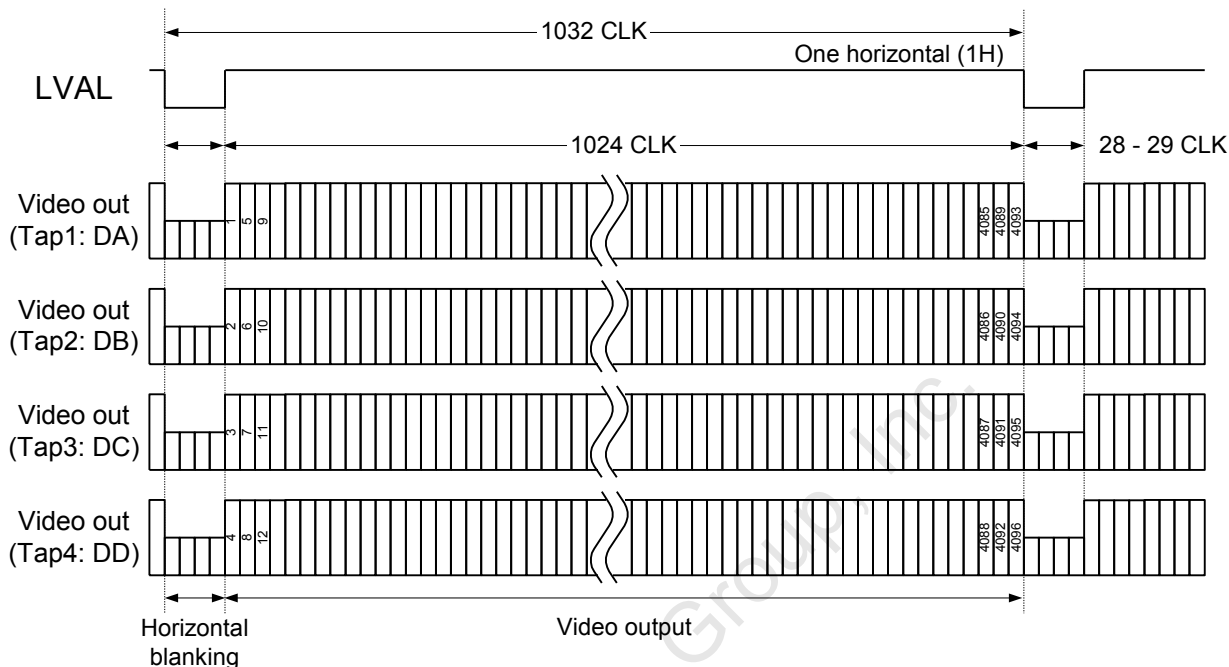
1 CLK = 11.764 nseconds(85MHz)
 1 CLK = 23.524 nseconds(42.5MHz)

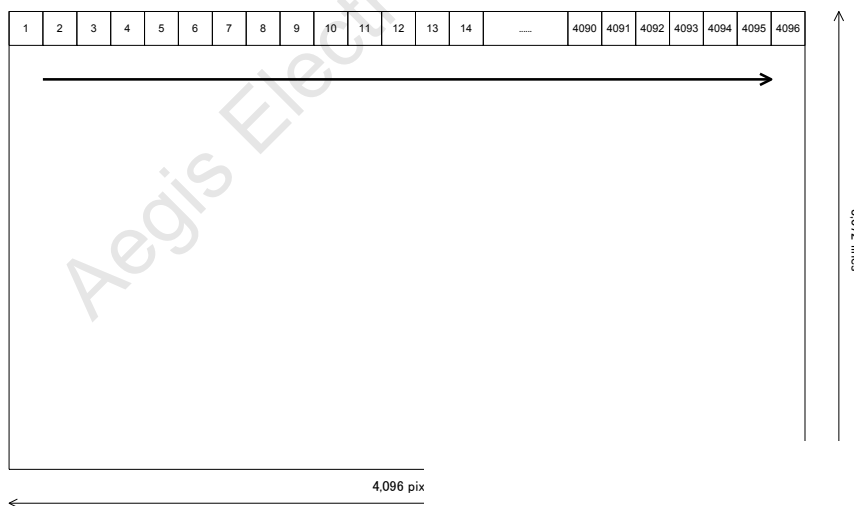

The pixel order for the Image



TAP1: DA output pixels	1	5	9	13	17	21
TAP2: DB output pixels	2	6	10	14	18	22
TAP3: DC output pixels	3	7	11	15	19	23
TAP4: DD output pixels	4	8	12	16	20	24

Aegis (888)687-6877
 ELECTRONIC GROUP, INC
 aegis-g2@aegiselect.com

4.1.4 3 Taps (1X3-1Y) / Horizontal 4,092 pixels

1 CLK = 11.764 nseconds(85MHz)
 1 CLK = 23.524 nseconds(42.5MHz)

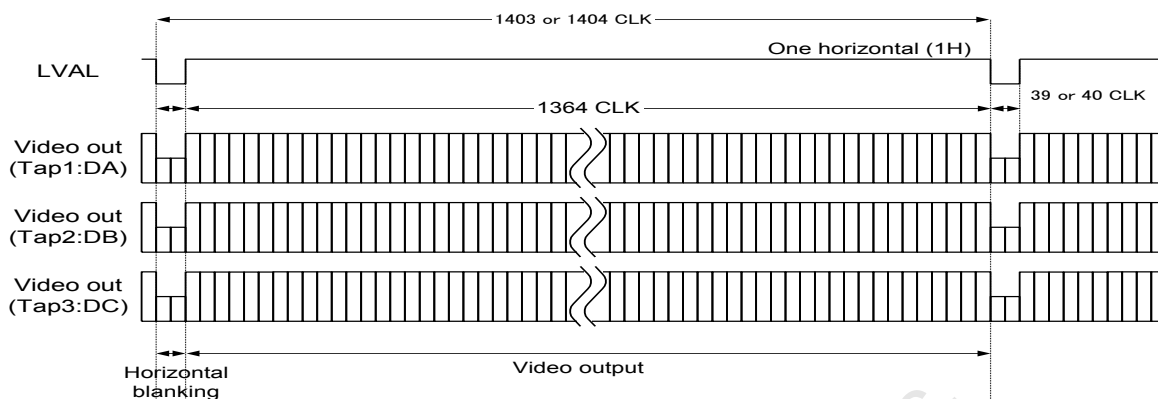

4.1.5 2 Taps (1X2-1Y) / Horizontal : 4,096 pixels

1 CLK = 11.764 nseconds(85MHz)
 1 CLK = 23.524 nseconds(42.5MHz)

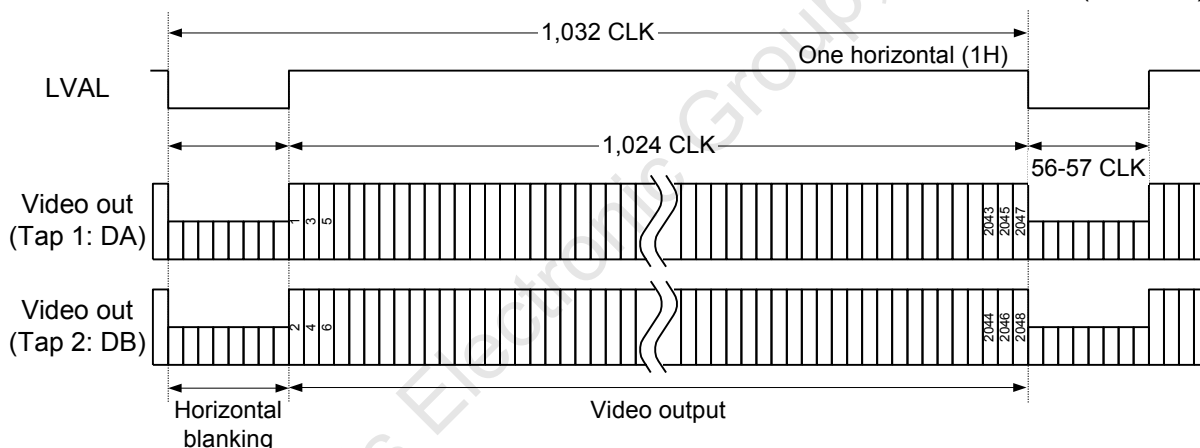

The pixel order for the Image

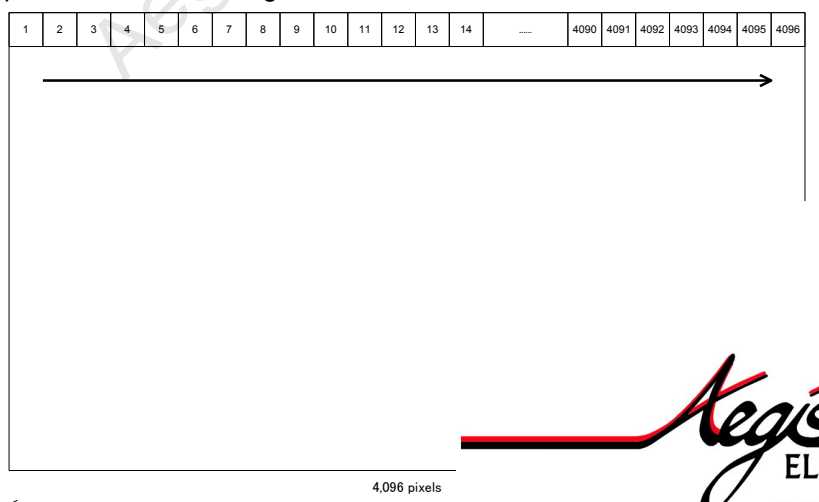

TAP1: DA output pixels

1	3	5	7	9	11
---	---	---	---	---	----

TAP2: DB output pixels

2	4	6	8	10	12
---	---	---	---	----	----

Aegis (888)687-6877
 ELECTRONIC GROUP, INC
aegis-g2@aegiselect.com

4.2 The Vertical timings

As for Horizontal timing, please refer to the [The horizontal timings \(CMC120APCL\)](#).
Three Video scan modes exist. The detail for these three scan modes are described as below.

- Full scan: All of line and pixel output from the camera
- Binning: Averaged pixel value output from the camera
- Subsampling: Skipped the lines and pixels output from the camera

Overview of Full scan

All of the lines and pixels are output and the entire image is shown. For transmitting the image, some configurations will not be supported, or can drop the frame rate.

4.3 Full Scan (TC-CMC120APCL / STC-CMB120APCL)

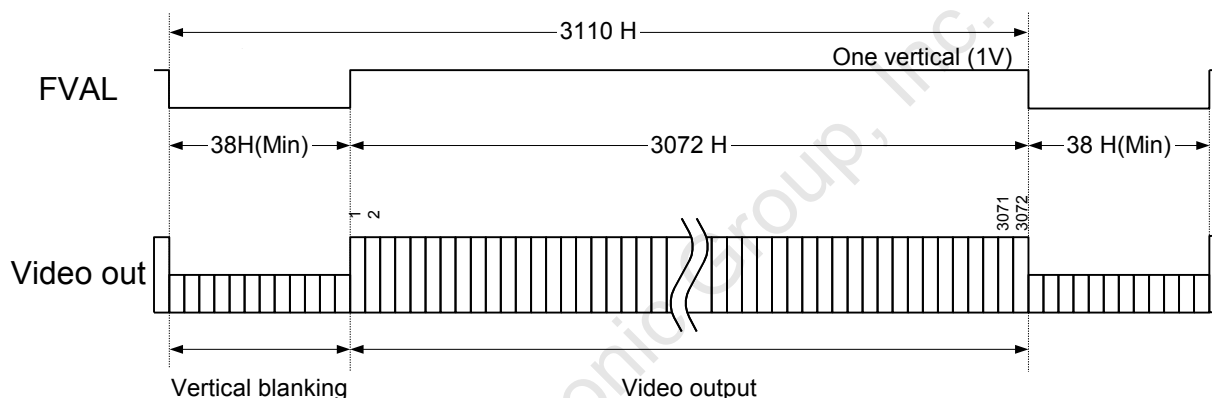

Table of Video Output on Full Scan mode (STC-CMC120APCL / STC-CMB120APCL)

Mode (EEH)	Tap Number	Configuration	CameraLink Output PixelClock Frequency(MHz)	Horizontal Pixel (Pixel)	FPS[fps]	Camera Link Output Bit
0	2	Base	85.0	4096	12.9	8/10/12
			42.5		6.4	
16	3	Base	85.0	4092	19.4	8
			42.5		9.8	
1	4	MEDIUM	85.0	4096	25.9	8/10/12
			42.5		12.9	
2	8	FULL	85.0	4096	51.8	8
			42.5		25.9	
3	10	DECA	85.0	4090	62.3	8
			42.5		31.1	

(888)687-6877
 ELECTRONIC GROUP, INC
 aegis-g2@aegiselect.com

4.4 AOI Output Timing

- This camera can be set the AOI up to 8.
- Variable Partial Start Line(VAS*), Variable Partial Effective Line(VAH*), Horizontal Start Position(HAS*), Horizontal Effective Pixel(HAW*) can be set for each eight regions. One region can be set on horizontal direction. And vertical area can not be overlapped for each region.

As follows setting is the example of four area of interest (AOI)

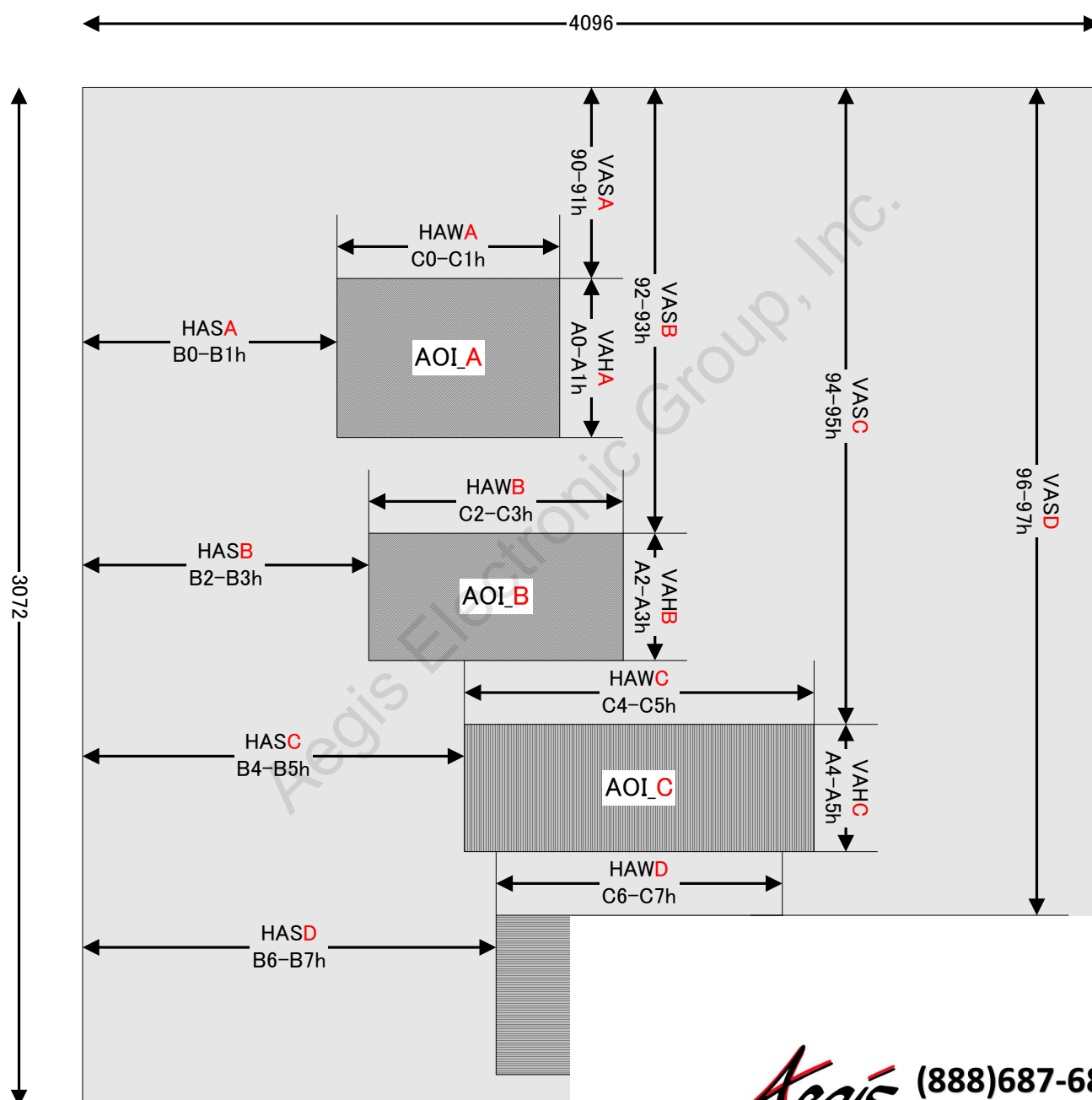

Aegis (888)687-6877
 ELECTRONIC GROUP, INC
 aegis-g2@aegiselect.com

Camera Link Output timing on AOI is as follow.

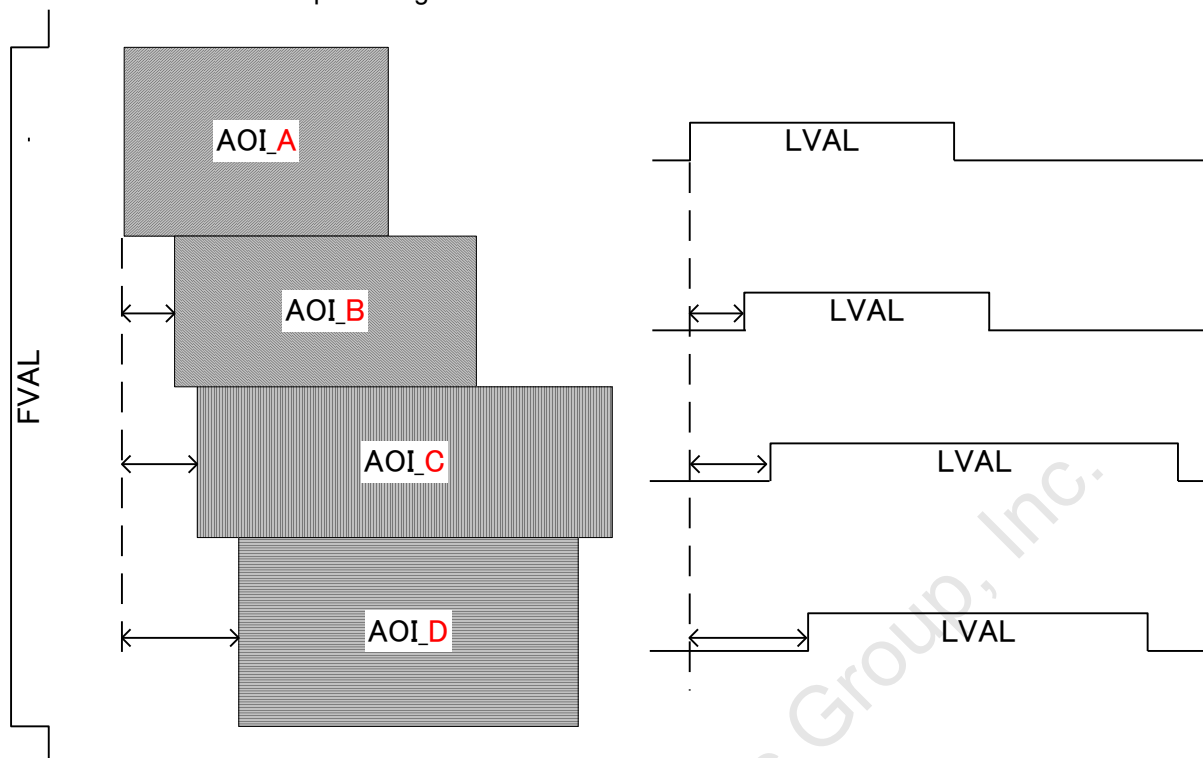

AOI images output as consecutive image.

Horizontal pixel number can be reduced through Horizontal Effective Pixel(HAW*) on AOI.

AOI on Color camera

Variable Partial Start Line(VAS*), Variable Partial Effective Line(VAH*) can be set two lines each.
Horizontal Start Position(HAS*), Horizontal Effective Pixel(HAW*) can be set two pixels each.

Frame rate on AOI

Maximum frame rate can be achieved through Variable Partial Effective Line(VAH*).
Horizontal Effective Pixel(HAW*) is not relate to maximum frame rate.

(888)687-6877
ELECTRONIC GROUP, INC
aegis-g2@aegiselect.com

Formula of maximum frame rate

- 10TAP CameraLink Clock: 85MHz
 $50 / 258 / \text{Variable Partial Effective Line(VAH*)} + 38) \times 10^6$ [fps] (Round down numbers beyond the second decimal point)
- 10TAP CameraLink Clock: 42.5MHz
 $25 / 258 / \text{Variable Partial Effective Line(VAH*)} + 38) \times 10^6$ [fps] (Round down numbers beyond the second decimal point)
- 8TAP CameraLink Clock: 85MHz
 $41.6 / 258 / \text{Variable Partial Effective Line(VAH*)} + 38) \times 10^6$ [fps] (Round down numbers beyond the second decimal point)
- 8TAP CameraLink Clock: 42.5MHz, 4TAP CameraLink Clock: 85MHz
 $20.8 / 258 / \text{Variable Partial Effective Line(VAH*)} + 38) \times 10^6$ [fps] (Round down numbers beyond the second decimal point)
- 4TAP CameraLink Clock: 42.5MHz, 2TAP CameraLink Clock: 85MHz
 $10.4 / 258 / \text{Variable Partial Effective Line(VAH*)} + 38) \times 10^6$ [fps] (Round down numbers beyond the second decimal point)
- 2TAP CameraLink Clock: 42.5MHz
 $5.2 / 258 / \text{Variable Partial Effective Line(VAH*)} + 38) \times 10^6$ [fps] (Round down numbers beyond the second decimal point)
- 3TAP CameraLink Clock: 85MHz
 $15.6 / 258 / \text{Variable Partial Effective Line(VAH*)} + 38) \times 10^6$ [fps] (Round down numbers beyond the second decimal point)
- 3TAP CameraLink Clock: 42.5MHz
 $7.8 / 258 / \text{Variable Partial Effective Line(VAH*)} + 38) \times 10^6$ [fps] (Round down numbers beyond the second decimal point)

Aegis Electronic Group, Inc.

Aegis (888)687-6877
 ELECTRONIC GROUP, INC
 aegis-g2@aegiselect.com

4.5 Camera Link bit assignment

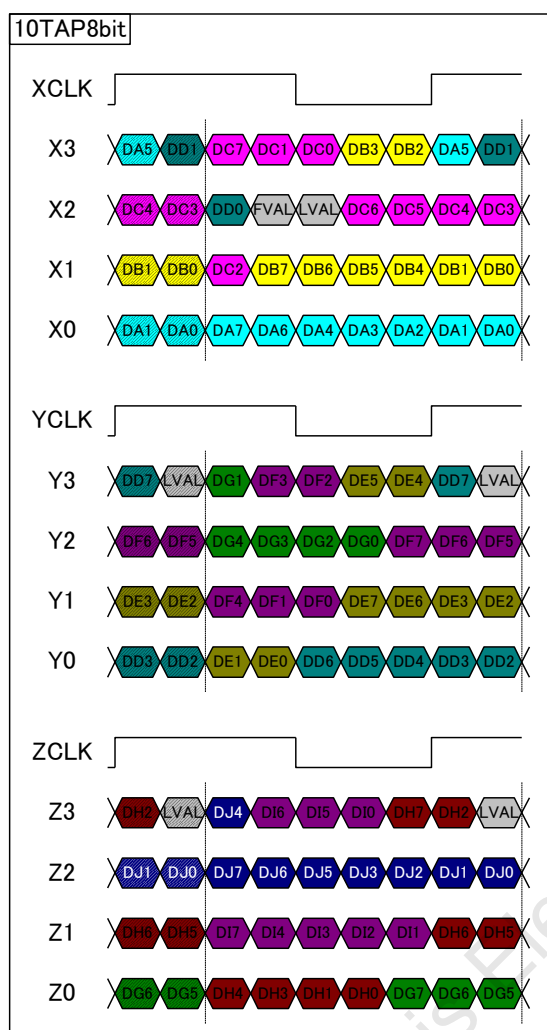

DA0 to DA7: 8bit data for one pixel from TAP1
 DB0 to DB7: 8bit data for one pixel from TAP2
 DC0 to DC7: 8bit data for one pixel from TAP3
 DD0 to DD7: 8bit data for one pixel from TAP4
 DE0 to DE7: 8bit data for one pixel from TAP5
 DF0 to DF7: 8bit data for one pixel from TAP6
 DG0 to DG7: 8bit data for one pixel from TAP7
 DH0 to DH7: 8bit data for one pixel from TAP8
 DI0 to DI7: 8bit data for one pixel from TAP9
 DJ0 to DJ7: 8bit data for one pixel from TAP10

(888)687-6877
 ELECTRONIC GROUP, INC
 aegis-g2@aegiselect.com

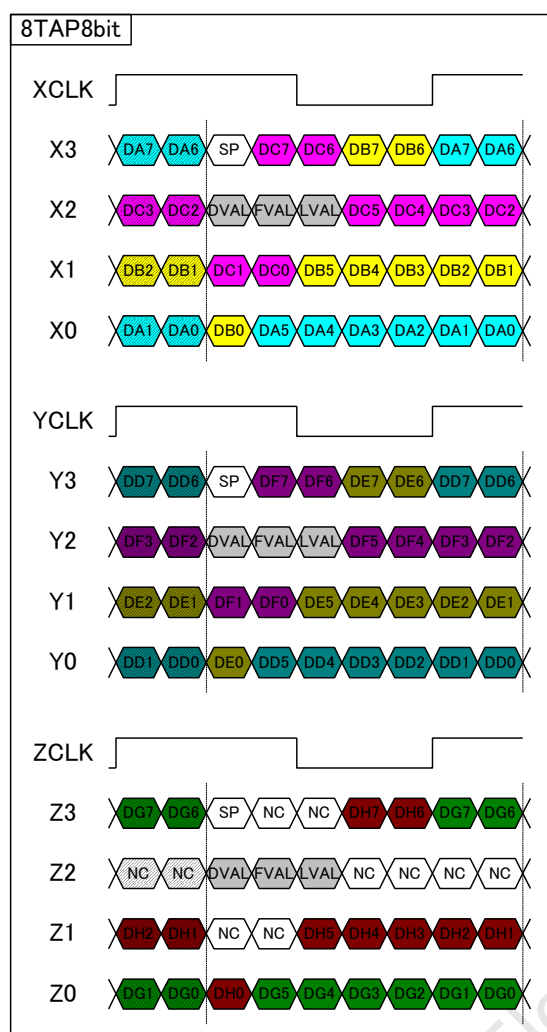

DA0 to DA7: 8bit data for one pixel from TAP1
 DB0 to DB7: 8bit data for one pixel from TAP2
 DC0 to DC7: 8bit data for one pixel from TAP3
 DD0 to DD7: 8bit data for one pixel from TAP4
 DE0 to DE7: 8bit data for one pixel from TAP5
 DF0 to DF7: 8bit data for one pixel from TAP6
 DG0 to DG7: 8bit data for one pixel from TAP7
 DH0 to DH7: 8bit data for one pixel from TAP8

(888)687-6877
 ELECTRONIC GROUP, INC
 aegis-g2@aegiselect.com

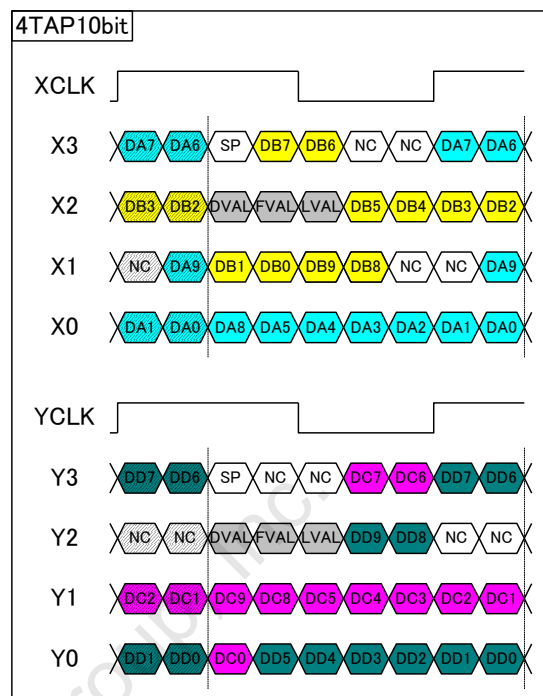
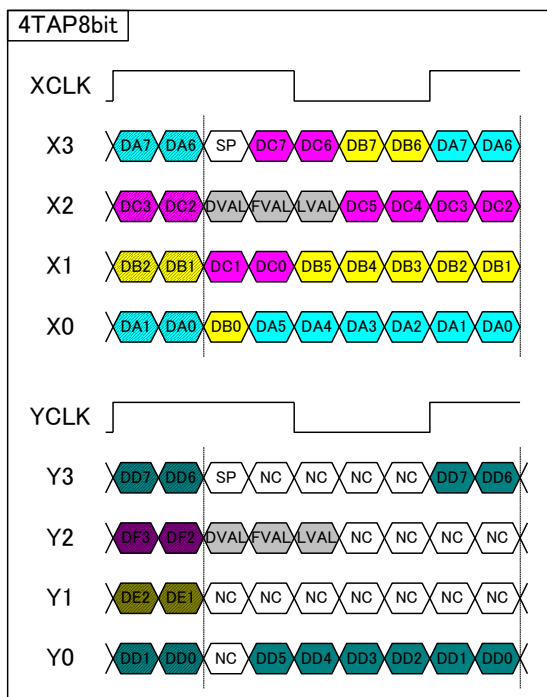

DA0 to DA7: 8bit data for one pixel from TAP1
 DB0 to DB7: 8bit data for one pixel from TAP2
 DC0 to DC7: 8bit data for one pixel from TAP3
 DD0 to DD7: 8bit data for one pixel from TAP4

DA0 to DA9: 10bit data for one pixel from TAP1
 DB0 to DB9: 10bit data for one pixel from TAP2
 DC0 to DC9: 10bit data for one pixel from TAP3
 DD0 to DD9: 10bit data for one pixel from TAP4

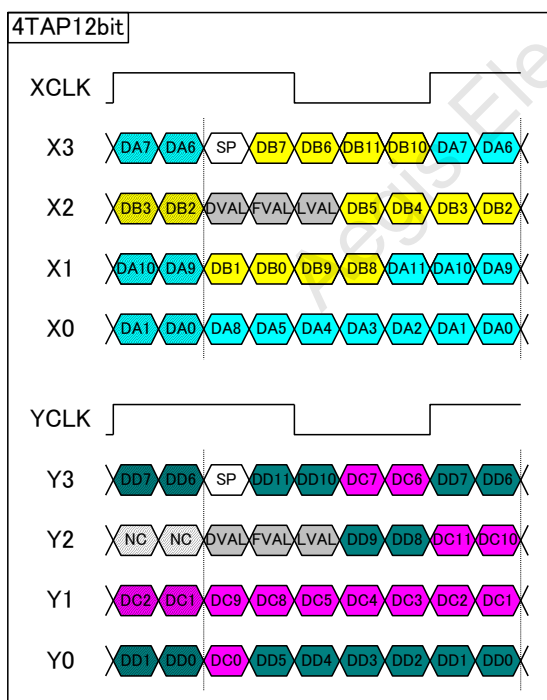

DA0 to DA11: 10bit data for one pixel from TAP1
 DB0 to DB11: 10bit data for one pixel from TAP2
 DC0 to DC11: 10bit data for one pixel from TAP3
 DD0 to DD11: 10bit data for one pixel from TAP4

Aegis (888)687-6877
 ELECTRONIC GROUP, INC
 aegis-g2@aegiselect.com

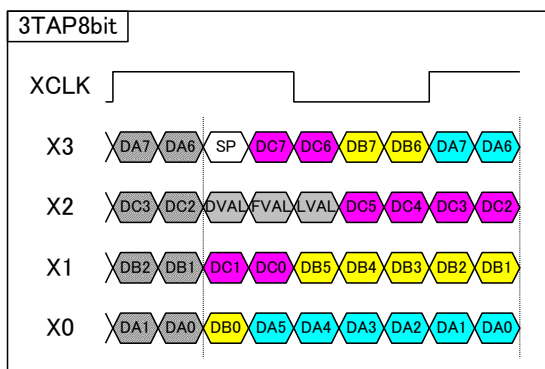

DA0 to DA7: 8bit data for one pixel from TAP1
 DB0 to DB7: 8bit data for one pixel from TAP2
 DC0 to DC7: 8bit data for one pixel from TAP3

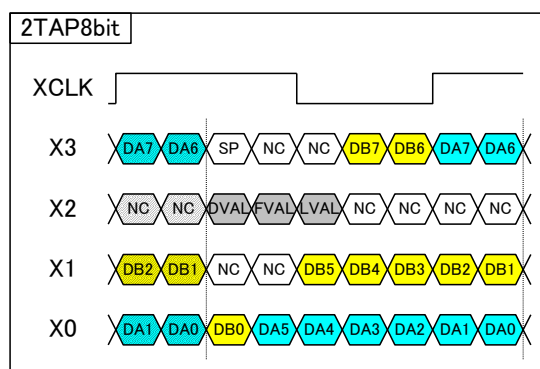

DA0 to DA7: 8bit data for one pixel from TAP1
 DB0 to DB7: 8bit data for one pixel from TAP2

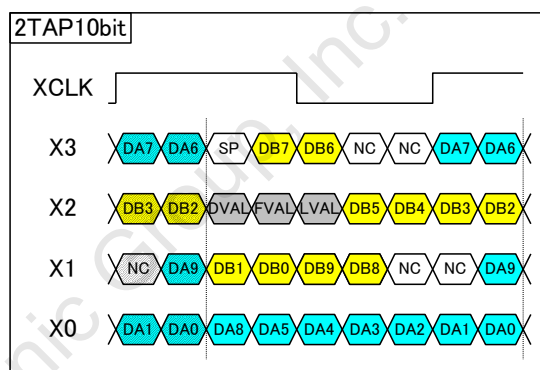

DA0 to DA9: 10bit data for one pixel from TAP1
 DB0 to DB9: 10bit data for one pixel from TAP2

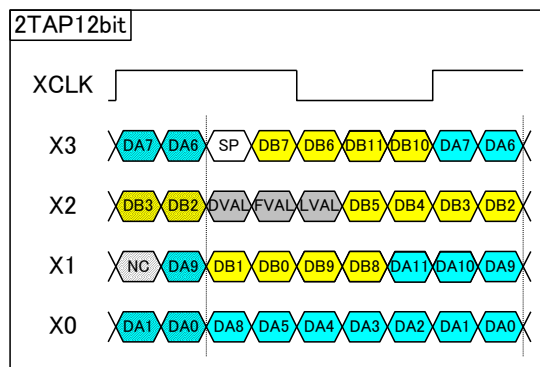

E
E

Aegis Electronic Group, Inc.

Aegis (888)687-6877
 ELECTRONIC GROUP, INC
 aegis-g2@aegiselect.com

4.6 Camera Link TAP Geometry
4.6.1 10TAP (1X10-1Y)

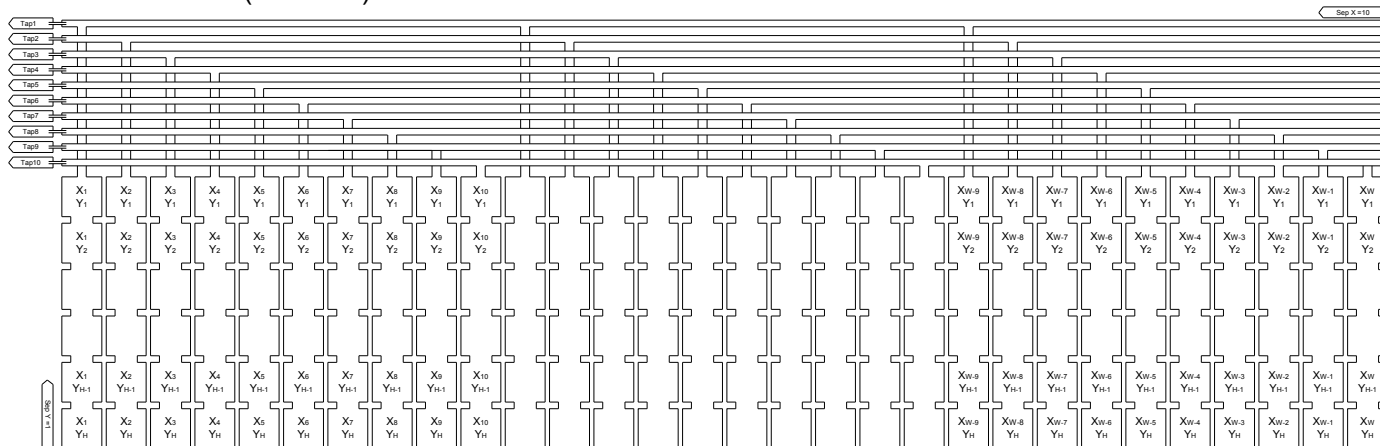

4.6.2 8TAP (1X8-1Y)

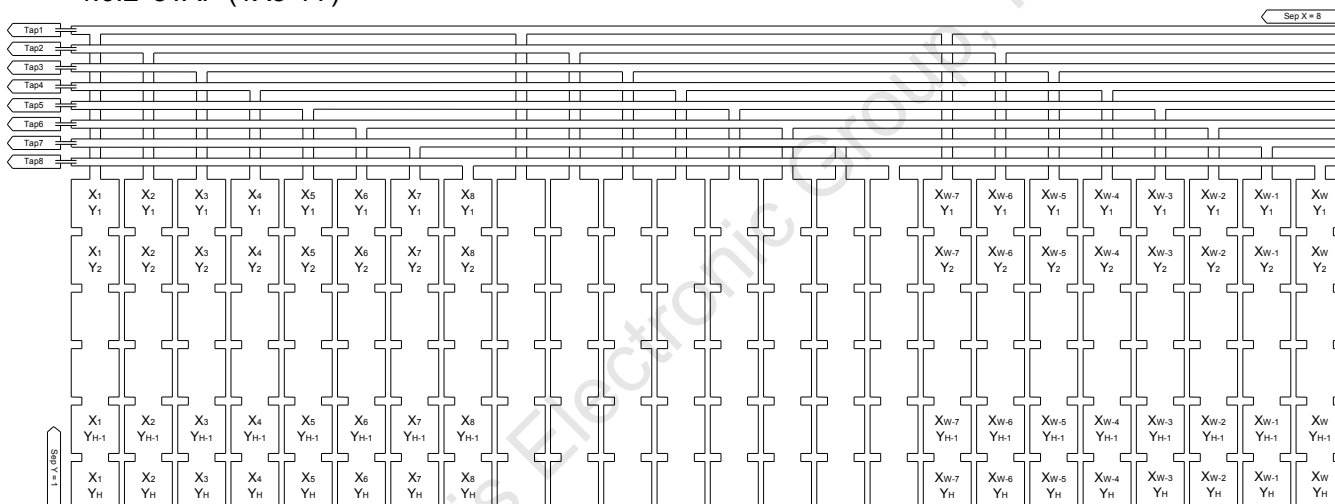

Aegis Electronic Group, Inc.

Aegis (888)687-6877
ELECTRONIC GROUP, INC
aegis-g2@aegiselect.com

4.6.3 4TAP (1X4-1Y)

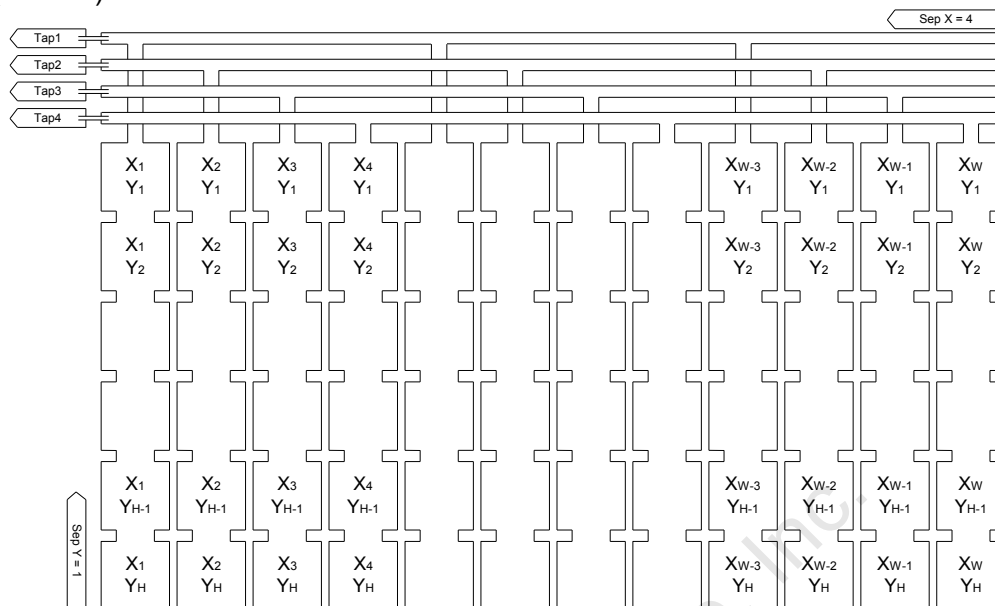

4.6.4 2TAP (1X2-1Y)

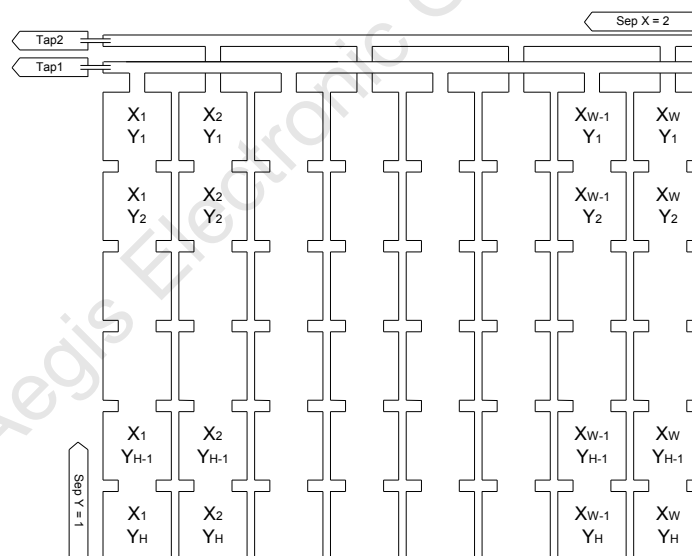

Aegis (888)687-6877
 ELECTRONIC GROUP, INC
 aegis-g2@aegiselect.com

4.7 Bayer pattern for color model (Only STC-CMC120APCL)

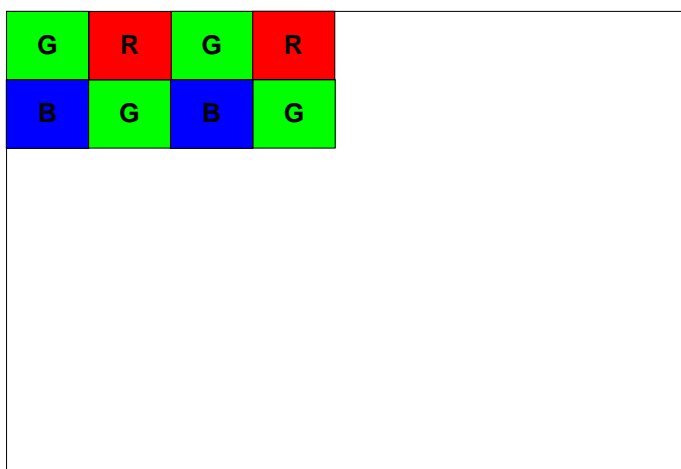

Aegis Electronic Group, Inc.

Aegis (888)687-6877
ELECTRONIC GROUP, INC
aegis-g2@aegiselect.com

5 Camera function modes

5.1 Normal mode

5.1.1 Normal mode (Electronic shutter)

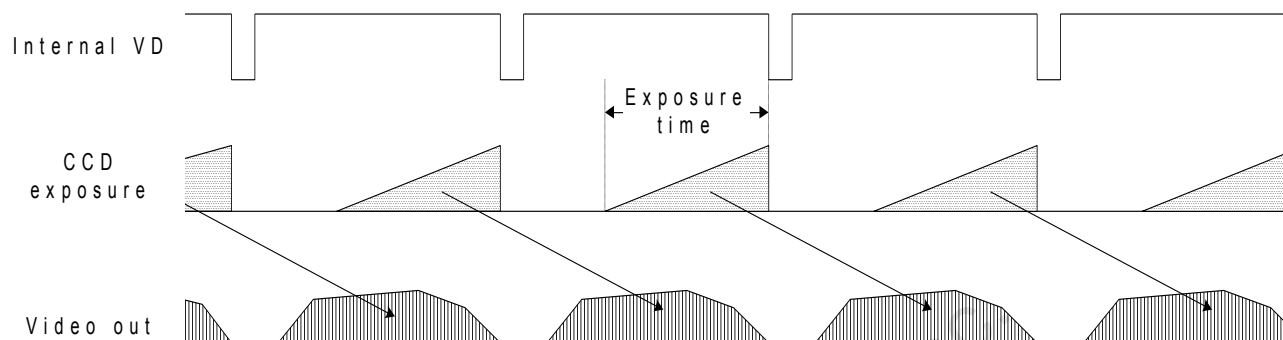

Aegis Electronic Group, Inc.

Aegis (888)687-6877
ELECTRONIC GROUP, INC
aegis-g2@aegiselect.com

5.2 Pulse width trigger mode

In this trigger mode with positive polarity, the camera exposure starts at the rising edge of the trigger pulse and stops at the falling edge of the trigger pulse. Therefore, In the case of the exposure positive polarity is selected, the exposure periods are the high states of the trigger pulse.

5.2.1 Pulse width trigger mode

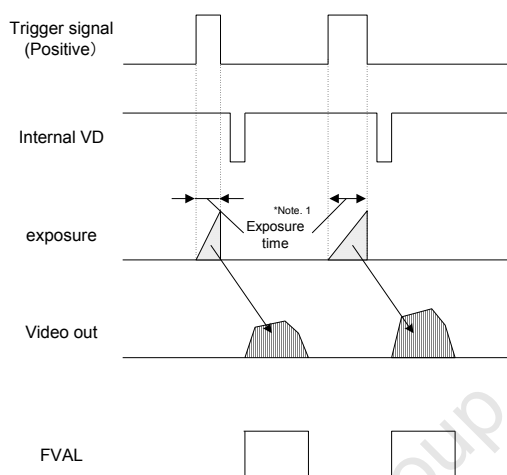

Note.1: The exposure time sets by the pulse width of the trigger signal. No FVAL output without any trigger signal.

5.2.2 Pulse Width Trigger mode (Exposure timing)

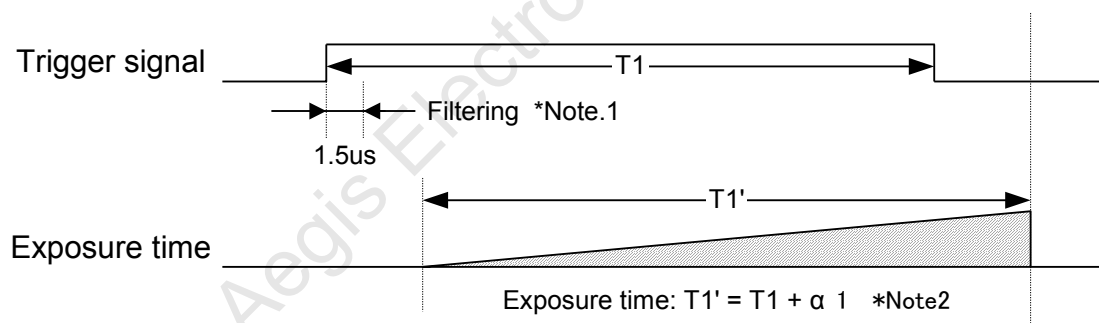

Note.1: The trigger signal is removed by the filtering if the pulse width of the input trigger signal is less than 1.5us. Please input the trigger signal has more than 1.5 us pulse width.

Note.2: $\alpha 1$ (Exposure time offset) is.
 10,8,4,2TAP
 41[us] (Edge Preset and Variable at Lin
 42[us] (Pulse Width and Variable at us t

3TAP
 42[us] (Edge Preset and Variable at Lin
 43[us] (Pulse Width and Variable at us t

(888)687-6877
 ELECTRONIC GROUP, INC
 aegis-g2@aegiselect.com

5.3 Edge Preset Trigger mode

In this trigger mode, the camera exposure starts at the rising edge of the trigger pulse or negative edge when setting is "Trigger Polarity::Negative", the camera exposure starts at the falling edge of the trigger pulse. Exposure duration time is preset by the "Electrical Shutter" settings.

5.3.1 Edge Preset Trigger mode

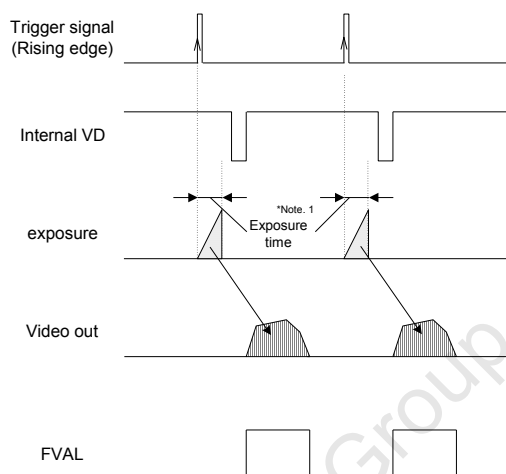

Note.1: The exposure time sets by the preset electronic shutter speed.

5.3.2

5.3.3 Edge Preset Trigger mode (Exposure timing)

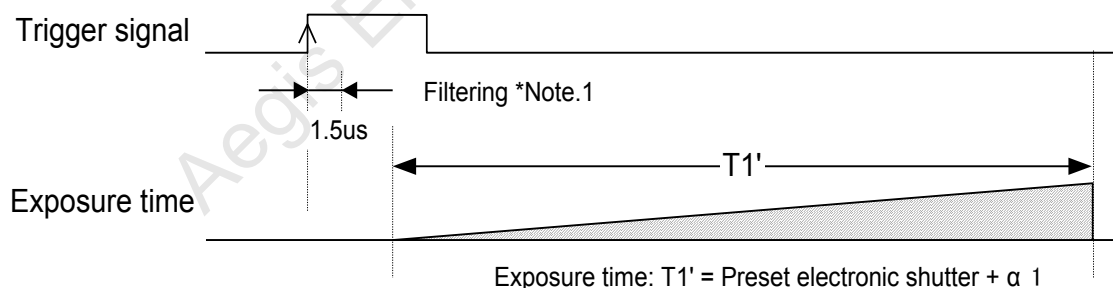

Note.1: The trigger signal is removed by the filtering.
Please input the trigger signal has more than

Note.2: $\alpha 1$ (Exposure time offset) is.
10,8,4,2TAP
41[us] (Edge Preset and Variable at Lin
42[us] (Pulse Width and Variable at us t
3TAP
42[us] (Edge Preset and Variable at Lin
43[us] (Pulse Width and Variable at us t

(888)687-6877
ELECTRONIC GROUP, INC
aegis-g2@aegiselect.com

6 The communication protocol specifications

This camera has the communication function that enables external devices like PC control the camera functions. Please use "CLCtrl2 (Version1.01 or later)" communication software or use following the communication protocol to communicate to the camera.

Note.

The communication problem may occur under the following conditions:

1. When the external sync frequency is illegal (more than 1% off from the specified frequency).
2. When external sync is unstable (In another word the bad external sync signal).
3. About for one second after switching from/to external sync mode to/from internal sync mode.
4. About for one second after switching frame rate.

6.1 The communication method

UART (RS232C), Binary communication

6.2 The communication settings

	Settings
Baud rate	9,600bps / 38,400bps / 57,600bps / 115,200bps
Data bit	8bit
Parity	None
Stop bit	1bit
Flow control	None

 **(888)687-6877**
 ELECTRONIC GROUP, INC
aegis-g2@aegiselect.com

6.3 The communication format

A. The sending data format from the PC to the camera is as follows:

a. Send the read command

SOF (8bit)	Device code (6bit)	Read (1bit)	Page selection (1bit)	Command code (8bit)	Data length (8bit)	Data (1byte)	EOF (8bit)
---------------	-----------------------	----------------	--------------------------	------------------------	-----------------------	-----------------	---------------

b. Send the write command

SOF (8bit)	Device code (6bit)	Write (1bit)	Page selection (1bit)	Command code (8bit)	Data length (8bit)	Data (Data length byte)	EOF (8bit)
---------------	-----------------------	-----------------	--------------------------	------------------------	-----------------------	----------------------------	---------------

B. The receiving data format from the camera is as follows:

a. After sent the read command

SOF (8bit)	Data length (8bit)	Data (Data length byte)	EOF (8bit)
---------------	-----------------------	----------------------------	---------------

b. After sent the write command

SOF (8bit)	Data length (8bit) "00"	Receiving code (8bit)	EOF (8bit)
---------------	----------------------------	--------------------------	---------------

C. Descriptions of the format

Name	Descriptions
SOF	Start of the frame Sets (or gets) the value is as "02H" always.
Device code	Sets the device code of the camera is as "000000".
Read / Write	Sets (or gets) "0" when send read command. Sets (or gets) "1" when send write command.
Page selection	Sets "0" when access to the command register of the camera Gets current data from the command register when sent read command. The data of the command register is replaced by the sent data when sent write command. The data of the EEPROM is not replaced. Sets "1" when access to the EEPROM of the camera The camera works with the data of the EEPROM when the power on the camera. Gets the data from the EEPROM when sent read. The data of the EEPROM is replaced by sent data when sent write command. The camera sends the receiving code as "01H" to the PC after the data of the EEPROM is replaced. The camera rejects other commands while the data of the EEPROM is being replaced (approximately 5 msec. / byte).
Command code	Please refer from the following page.
Data length	Data length (Unit: byte) Receiving data The data length is depending on the command after sent read command. The data length is "00H" after sent write command. Sending data The data length is 1 byte when send read command. The data length is depending on the command when send write command.
Data	The value of the data is depending on the command
EOF	End of the frame Sets (or gets) the value is as "03H" always
Receiving code	Result of the sending command 01H: OK (ACK), 11H: Communication problem

D. Example command

Send the read command to read the 00H address:
02, 00, 00, 01, 00, 03
SOF, (Device code/Read/Register), Comma

The return command
02, 01, 00, 03

 (888)687-6877
ELECTRONIC GROUP, INC
aegis-g2@aegiselect.com

6.4 The camera control commands

6.4.1 The camera commands list(Device Code:00H)

Note. 1: The data unit of the each command is 1byte (8bit).

Note. 2: The data can be saved to the EEPROM if “x” in the “Save to EEPROM” column in the list.
The camera is operating with the data of the EEPROM when the power on the camera.

Command No.	Read /Write	Save to EEPROM	Function	Initial Data	Data Range
09-0FH			Reserved	-	
10H	R/W	O	The camera function mode 1 (8bit: D[7..0])	1	
11H	R/W	O	The camera function mode 2 (8bit: D[7..0])	08H	
12H	R/W	O	The camera function mode 3 (8bit: D[7..0])	50H	
13H			Reserved	-	
14H	R/W	O	The communication mode (8bit: D[7..0])	0	
15-1FH			Reserved	-	
20H	R/W	O	The exposure time of the electronic shutter (16bit: D[7..0])	1.536	1 to 16,777,215
21H	R/W	O	The exposure time of the electronic shutter (16bit: D[15..8])		
22H	R/W	O	The exposure time of the electronic shutter (16bit: D[23..16])		
23-27H			Reserved	-	
28H	R/W	O	The delay time for the trigger (8bit: D[7..0])	0	0 to 255
29-30H			Reserved	-	-
31H	R/W	O	The digital gain (8bit: D[7..0])	0	-
32-37H			Reserved	-	
38H	R/W	O	The clamp level (8bit: D[7..0])	40	0 to 80
39H			Reserved	-	-
3AH	R/W	O	White Balance R gain (8bit: D[7..0])	0	0 to 255
3BH	R/W	O	White Balance B gain (8bit: D[7..0])	0	0 to 255
3CH	R/W	O	White Balance Gr gain (8bit: D[7..0])	0	0 to 255
3DH	R/W	O	White Balance Gb gain (8bit: D[7..0])	0	0 to 255
3E-46H			Reserved	-	
47H	R/W	O	HDR / Number of Slopes	1	
48-4AH			Reserved	-	
4BH	R/W	O	PGA (8bit: D[7..0])	0	
4C-55H			Reserved	-	
56H	R/W	O	Knee1 Point	1	
57H	R/W	O	Knee2 Point	1	
58-5AH			Reserved	-	
5BH	R/W		Vlow2 Volt	64	64 to 127
5CH	R/W		Vlow3 Volt	64	64 to 127
5D-67H			Reserved	-	
68H	R/W	O	Horizontal Flip	0	
78H	R/W	O	Test Pattern (8bit: D[7..0])		
79H	R/W	O	Image effect selection (8bit: D[7..0])		
7A-7FH			Reserved	-	
80H	R/W	O	EEPROM Control (8bit: D[7..0])		
81H	R/W	O	Factory Default Load (8bit: D[7..0])		
82-8FH			Reserved	-	

(888)687-6877
ELECTRONIC GROUP, INC
aegis-g2@aegiselect.com

Command No.	Read /Write	Save to EEPROM	Function	Initial Data	Data Range
90H	R/W	0	The start line of the variable partial scanning A (16bit: D[7..0])	0	0 to 3,068
91H	R/W	0	The start line of the variable partial scanning A (16bit: D[15..8])		
92H	R/W	0	The start line of the variable partial scanning B (16bit: D[7..0])	0	0 to 3,068
93H	R/W	0	The start line of the variable partial scanning B (16bit: D[15..8])		
94H	R/W	0	The start line of the variable partial scanning C (16bit: D[7..0])	0	0 to 3,068
95H	R/W	0	The start line of the variable partial scanning C (16bit: D[15..8])		
96H	R/W	0	The start line of the variable partial scanning D (16bit: D[7..0])	0	0 to 3,068
97H	R/W	0	The start line of the variable partial scanning D (16bit: D[15..8])		
98H	R/W	0	The start line of the variable partial scanning E (16bit: D[7..0])	0	0 to 3,068
99H	R/W	0	The start line of the variable partial scanning E (16bit: D[15..8])		
9AH	R/W	0	The start line of the variable partial scanning F (16bit: D[7..0])	0	0 to 3,068
9BH	R/W	0	The start line of the variable partial scanning F (16bit: D[15..8])		
9CH	R/W	0	The start line of the variable partial scanning G (16bit: D[7..0])	0	0 to 3,068
9DH	R/W	0	The start line of the variable partial scanning G (16bit: D[15..8])		
9EH	R/W	0	The start line of the variable partial scanning H (16bit: D[7..0])	0	0 to 3,068
9FH	R/W	0	The start line of the variable partial scanning H (16bit: D[15..8])		
A0H	R/W	0	The effective lines of the variable partial scanning A (16bit: D[7..0])	3072	4 to 3072
A1H	R/W	0	The effective lines of the variable partial scanning A (16bit: D[15..8])		
A2H	R/W	0	The effective lines of the variable partial scanning B (16bit: D[7..0])	0	0 to 3072
A3H	R/W	0	The effective lines of the variable partial scanning B (16bit: D[15..8])		
A4H	R/W	0	The effective lines of the variable partial scanning C (16bit: D[7..0])	0	0 to 3072
A5H	R/W	0	The effective lines of the variable partial scanning C (16bit: D[15..8])		
A6H	R/W	0	The effective lines of the variable partial scanning D (16bit: D[7..0])	0	0 to 3072
A7H	R/W	0	The effective lines of the variable partial scanning D (16bit: D[15..8])		
A8H	R/W	0	The effective lines of the variable partial scanning E (16bit: D[7..0])	0	0 to 3072
A9H	R/W	0	The effective lines of the variable partial scanning E (16bit: D[15..8])		
AAH	R/W	0	The effective lines of the variable partial scanning F (16bit: D[7..0])	0	0 to 3072
ABH	R/W	0	The effective lines of the variable partial scanning F (16bit: D[15..8])		
ACH	R/W	0	The effective lines of the variable partial scanning G (16bit: D[7..0])	0	0 to 3072
ADH	R/W	0	The effective lines of the variable partial scanning G (16bit: D[15..8])		
AEH	R/W	0	The effective lines of the variable partial scanning H (16bit: D[7..0])	0	0 to 3072
AFH	R/W	0	The effective lines of the variable partial scanning H (16bit: D[15..8])		

Aegis

(888)687-6877
 ELECTRONIC GROUP, INC
aegis-g2@aegiselect.com

Command No.	Read /Write	Save to EEPROM	Function	Initial Data	Data Range
B0H	R/W	0	The start Pixel of the variable partial scanning A (16bit: D[7..0])	0	0 to 4095
B1H	R/W	0	The start Pixel of the variable partial scanning A (16bit: D[15..8])		
B2H	R/W	0	The start Pixel of the variable partial scanning B (16bit: D[7..0])	0	0 to 4095
B3H	R/W	0	The start Pixel of the variable partial scanning B (16bit: D[15..8])		
B4H	R/W	0	The start Pixel of the variable partial scanning C (16bit: D[7..0])	0	0 to 4095
B5H	R/W	0	The start Pixel of the variable partial scanning C (16bit: D[15..8])		
B6H	R/W	0	The start Pixel of the variable partial scanning D (16bit: D[7..0])	0	0 to 4095
B7H	R/W	0	The start Pixel of the variable partial scanning D (16bit: D[15..8])		
B8H	R/W	0	The start Pixel of the variable partial scanning E (16bit: D[7..0])	0	0 to 4095
B9H	R/W	0	The start Pixel of the variable partial scanning E (16bit: D[15..8])		
BAH	R/W	0	The start Pixel of the variable partial scanning F (16bit: D[7..0])	0	0 to 4095
BBH	R/W	0	The start Pixel of the variable partial scanning F (16bit: D[15..8])		
BCH	R/W	0	The start Pixel of the variable partial scanning G (16bit: D[7..0])	0	0 to 4095
BDH	R/W	0	The start Pixel of the variable partial scanning G (16bit: D[15..8])		
BEH	R/W	0	The start Pixel of the variable partial scanning H (16bit: D[7..0])	0	0 to 4095
BFH	R/W	0	The start Pixel of the variable partial scanning H (16bit: D[15..8])		
C0H	R/W	0	The effective Pixel of the variable partial scanning A (16bit: D[7..0])	4096	0 to 4096
C1H	R/W	0	The effective Pixel of the variable partial scanning A (16bit: D[15..8])		
C2H	R/W	0	The effective Pixel of the variable partial scanning B (16bit: D[7..0])	0	0 to 4096
C3H	R/W	0	The effective Pixel of the variable partial scanning B (16bit: D[15..8])		
C4H	R/W	0	The effective Pixel of the variable partial scanning C (16bit: D[7..0])	0	0 to 4096
C5H	R/W	0	The effective Pixel of the variable partial scanning C (16bit: D[15..8])		
C6H	R/W	0	The effective Pixel of the variable partial scanning D (16bit: D[7..0])	0	0 to 4096
C7H	R/W	0	The effective Pixel of the variable partial scanning D (16bit: D[15..8])		
C8H	R/W	0	The effective Pixel of the variable partial scanning E (16bit: D[7..0])	0	0 to 4096
C9H	R/W	0	The effective Pixel of the variable partial scanning E (16bit: D[15..8])		
CAH	R/W	0	The effective Pixel of the variable partial scanning F (16bit: D[7..0])	0	0 to 4096
CBH	R/W	0	The effective Pixel of the variable partial scanning F (16bit: D[15..8])		
CCH	R/W	0	The effective Pixel of the variable partial scanning G (16bit: D[7..0])	0	0 to 4096
CDH	R/W	0	The effective Pixel of the variable partial scanning G (16bit: D[15..8])		
CEH	R/W	0	The effective Pixel of the variable partial scanning H (16bit: D[7..0])	0	0 to 4096
CFH	R/W	0	The effective Pixel of the variable partial scanning H (16bit: D[15..8])		
D0-DDH			Reserved	-	
DEH	R/W	0	Pixel Blemish Correction Mode1 (8bit: D[7..0])	1	
DFH	R/W	0	Pixel Blemish Correction Mode2 (8bit: D[15..8])	70H	
E0-E2H			Reserved	-	
E3H			FPN Correction Mode (8bit: D[7..0])	17	0 or 17
E4-EDH			Reserved	-	
EEH			Camera Operation Mode (16bit: D[7..0])	0	0 to 3
EFH			Camera Operation Mode (16bit: D[15..8])		or 16
F0-FFH			Reserved		

(888)687-6877
ELECTRONIC GROUP, INC
aegis-g2@aegiselect.com

6.4.2 Description of the camera control commands (The under line settings are the factory default settings)

Command No.	Command Descriptions								
10H: MOD1[7..0]	<p>[The camera function mode 1] Initial data: MOD1[7..0] = 01H Sets the camera function mode. D[7..0]</p> <table border="1"> <tr> <td>D7</td><td>D6</td><td>D5</td><td>D4</td><td>D3</td><td>D2</td><td>D1</td><td>D0</td> </tr> </table> <p>D7: No function Set always as "0" D6: Trigger polarity <u>0: Positive</u> 1: Negative D5: Trigger mode <u>0: Edge preset</u> 1: Pulse width D4 to D1: No function Sets always as "0000" D0: Exposure time unit <u>0: Line Unit</u> <u>1: usec Unit</u></p>	D7	D6	D5	D4	D3	D2	D1	D0
D7	D6	D5	D4	D3	D2	D1	D0		
11H: MOD2[7..0]	<p>[The camera function mode 2] Initial data : MOD2[7..0] = 08H Sets the camera function mode. D[7..0]</p> <table border="1"> <tr> <td>D7</td><td>D6</td><td>D5</td><td>D4</td><td>D3</td><td>D2</td><td>D1</td><td>D0</td> </tr> </table> <p>D7: No function Sets always as "0" D6 to D5: No function <u>00: 85MHz</u> 10: 42.5MHz 01,11: No function (Prohibited setting. Do not set these values) D4: No function Sets always as "0" D3: Function mode <u>0: Trigger mode</u> <u>1: Continuous mode</u> D2 to D0: No function Sets always as "000" * No video output without the trigger signal input while the camera works with the trigger mode.</p>	D7	D6	D5	D4	D3	D2	D1	D0
D7	D6	D5	D4	D3	D2	D1	D0		
12H: MOD3[7..0]	<p>[The camera function mode 3] Initial data: MOD3[7..0] = 50H Sets the camera function mode. D[7..0]</p> <table border="1"> <tr> <td>D7</td><td>D6</td><td>D5</td><td>D4</td><td>D3</td><td>D2</td><td>D1</td><td>D0</td> </tr> </table> <p>D7 to D6 Video out <u>00: 10bit</u> <u>01: 8bit</u> <u>10: 12bit , *12H</u> <u>11: No function</u> D5: Trigger signal input connector <u>0: Camera Link (CC1)</u> <u>1: Power/IO connector(No. 2 pin, SP4)</u> D4: Exposure start mode <u>0: Normal</u> <u>1: Horizontal Synchronization</u> D3 to D0: No function Sets always as "000"</p>	D7	D6	D5	D4	D3	D2	D1	D0
D7	D6	D5	D4	D3	D2	D1	D0		
14H: UART [7..0]	<p>[The communication mode] Initial data: UART[7..0] = 01H Sets the communication mode. D[7..0]</p> <table border="1"> <tr> <td>D7</td><td>D6</td><td>D5</td><td>D4</td><td>D3</td><td>D2</td><td>D1</td><td>D0</td> </tr> </table> <p>D7 to D2 No function D1 to D0: Communication mode</p>	D7	D6	D5	D4	D3	D2	D1	D0
D7	D6	D5	D4	D3	D2	D1	D0		

Command No.	Command Descriptions								
20H: SVR[7..0] 21H: SVR[15..8] 22H: SVR[23..16]	<p>[The exposure time of the electronic shutter] Initial data: SVR[23..0] = 1,536, Range: 1 to 16,777,215 Sets the preset shutter speed for electronic shutter.</p> <p>D[7..0]</p> <table border="1"> <tr> <td>D7</td> <td>D6</td> <td>D5</td> <td>D4</td> <td>D3</td> <td>D2</td> <td>D1</td> <td>D0</td> </tr> </table> <p>Case 10h.0 =0 (Exposure time on Usec unit)</p> <ul style="list-style-type: none"> • 10TAP Exposure time (shutter speed) = ((SVR[23..0] -1) x 258 + 1020) x 10 / 250 Unit: usec • 8,4,2TAP Exposure time (shutter speed) = ((SVR[23..0]-1) X 258 + 851) x 10 / 250 Unit: usec <p>*Minimum shutter speed with Pulse Width Trigger on Line unit is up to 41useconds</p> <ul style="list-style-type: none"> • 3TAP Exposure time (shutter speed) = ((SVR[23..0]-1) X 258 + 647) x 10 / 187.5 Unit: usec <p>*Minimum shutter speed with Pulse Width Trigger on Line unit is up to 42useconds</p> <p>10h.0=1 (Exposure time on Usec unit) Exposure time (shutter speed) = 1 X SVR[] Unit: usec *Minimum shutter speed on Usec unit is 10,8,4,2TAP up to 42useconds 3TAP up to 43useconds</p>	D7	D6	D5	D4	D3	D2	D1	D0
D7	D6	D5	D4	D3	D2	D1	D0		
28H: DLY[7..0]	<p>[The delay time for the trigger] Initial data: : DLY[7..0] = 0, Range: 0 to 255 Sets the delay time that is from the trigger signal input to start exposure. Delay time = 2us X DLY[7..0] (useconds)</p>								
31H: DGB[7..0]	<p>[The digital gain] Initial data: DGB[7..0] = 0 Video level = (Input video level - CLAMP[7..0]) X (1 + DGB[7..0] / 64) + CLAMP[7..0] CLAMP[7..0] : The clamp level (The value of the address 38H)</p>								
38H: CLAMP[7..0]	<p>[The clamp level] Initial data: CLAMP[7..0] = 40, Range: : 0 to 80 Sets the clamp level (The clamp level of the black signal). This value is as 10bit video image. When 8bit is selected, clamp level should be 1/4 of setting value.</p>								
3AH: WBR[7..0]	<p>[White Blance R Gain] Initial data: WBR[7..0] = 0, Range: 0to255 Set the Red gain on Bayer Video level = (Input video level - CLAMP[7..0]) X (1 + WBR[7..0] / 64) + CLAMP[7..0]</p>								
3BH: WBB[7..0]	<p>[White Blance B Gain] Initial data: WBB[7..0] = 0, Range: 0to255 Set the Blue gain on Bayer Video level = (Input video level - CLAMP[7..0]) X (1 + WBB[7..0] / 64) + CLAMP[7..0]</p>								
3CH: WBGR[7..0]	<p>[White Blance GR Gain] Initial data: WBGR[7..0] = 0, Range: 0to255 Set the Green gain on Bayer GR line Video level = (Input video level - CLAMP[7..0]) X (1 + WBGR[7..0] / 64) + CLAMP[7..0]</p>								
3DH: WBGB[7..0]	<p>[White Blance GB Gain] Initial data: WBGB[7..0] = 0, Range: 0to255 Set the Green gain on Bayer GB line Video level = (Input video level - CLAMP[7..0]) X (1 + WBGB[7..0] / 64) + CLAMP[7..0]</p>								

Command No.	Command Descriptions
90H: VASA[7..0] 91H: VASA[15..8]	[Vertical AOI Start Line AOI_A] Initial data: : VASA[15..0] = 0、 Range: 0 to 3,068 Sets Vertical AOI Start Line AOI_A. The value should be set 4 Lines each. (e.g. : 0、 4、 8、 to 3,068)
92H: VASB[7..0] 93H: VASB[15..8]	[Vertical AOI Start Line AOI_B] Initial data: : VASB[15..0] = 0、 Range: 0 to 3,068 Sets Vertical AOI Start Line AOI_B. Sets Vertical AOI Start Line AOI_A. The value should be set 4 Lines each. (e.g. : 0、 4、 8、 to 3,068)
94H: VASC[7..0] 95H: VASC[15..8]	[Vertical AOI Start Line AOI_C] Initial data: : VASC[15..0] = 0、 Range: 0 to 3,068 Sets Vertical AOI Start Line AOI_C. Sets Vertical AOI Start Line AOI_A. The value should be set 4 Lines each. (e.g. : 0、 4、 8、 to 3,068)
96H: VASD[7..0] 97H: VASD[15..8]	[Vertical AOI Start Line AOI_D] Initial data: : VASD[15..0] = 0、 Range: 0 to 3,068 Sets Vertical AOI Start Line AOI_D. Sets Vertical AOI Start Line AOI_A. The value should be set 4 Lines each. (e.g. : 0、 4、 8、 to 3,068)
98H: VASE[7..0] 99H: VASE[15..8]	[Vertical AOI Start Line AOI_E] Initial data: : VASE[15..0] = 0、 Range: 0 to 3,068 Sets Vertical AOI Start Line AOI_E. Sets Vertical AOI Start Line AOI_A. The value should be set 4 Lines each. (e.g. : 0、 4、 8、 to 3,068)
9AH: VASF[7..0] 9BH: VASF[15..8]	[Vertical AOI Start Line AOI_F] Initial data: : VASF[15..0] = 0、 Range: 0 to 3,068 Sets Vertical AOI Start Line AOI_F. Sets Vertical AOI Start Line AOI_A. The value should be set 4 Lines each. (e.g. : 0、 4、 8、 to 3,068)
9CH: VAG[7..0] 9DH: VAG[15..8]	[Vertical AOI Start Line AOI_G] Initial data: : VAG[15..0] = 0、 Range: 0 to 3,068 Sets Vertical AOI Start Line AOI_G. Sets Vertical AOI Start Line AOI_A. The value should be set 4 Lines each. (e.g. : 0、 4、 8、 to 3,068)
9EH: VASH[7..0] 9EH: VASH[15..8]	[Vertical AOI Start Line AOI_H] Initial data: : VASH[15..0] = 0、 Range: 0 to 3,068 Sets Vertical AOI Start Line AOI_H. Sets Vertical AOI Start Line AOI_A. The value should be set 4 Lines each. (e.g. : 0、 4、 8、 to 3,068)

(888)687-6877
 ELECTRONIC GROUP, INC
aegis-g2@aegiselect.com

Command No.	Command Descriptions
A0H: VAHA[7..0] A1H: VAHA[15..8]	[Vertical AOI Effective Line AOI_A] Initial data: VAHA[15..0] = 3,072、 Range: 4 to 3,072 Sets the number of the effective lines (image height) of the variable partial scanning. The value should be set 4 Lines each. The camera works with full scanning, when the total effective lines of the eight partial. (VAHA [] + VAHB[] + VAHC[] + VAHD[] + VAHE[] + VAHF[] + VAHG[] + VAHH[]) is greater than 3072.
A2H: VAHB[7..0] A3H: VAHB[15..8]	[Vertical AOI Effective Line AOI_B] Initial data: VAHB[15..0] = 0、 Range: 0 to 3,072 Sets the number of the effective lines (image height) of the variable partial scanning. The value should be set 4 Lines each. The camera works with full scanning, when the total effective lines of the eight partial. (VAHA [] + VAHB[] + VAHC[] + VAHD[] + VAHE[] + VAHF[] + VAHG[] + VAHH[]) is greater than 3072.
A4H: VAHC[7..0] A5H: VAHC[15..8]	[Vertical AOI Effective Line AOI_C] Initial data: VAHC[15..0] = 0、 Range: 0 to 3,072 Sets the number of the effective lines (image height) of the variable partial scanning. The value should be set 4 Lines each. The camera works with full scanning, when the total effective lines of the eight partial. (VAHA [] + VAHB[] + VAHC[] + VAHD[] + VAHE[] + VAHF[] + VAHG[] + VAHH[]) is greater than 3072.
A6H: VAHD[7..0] A7H: VAHD[15..8]	[Vertical AOI Effective Line AOI_D] Initial data: VAHD[15..0] = 0、 Range: 0 to 3,072 Sets the number of the effective lines (image height) of the variable partial scanning. The value should be set 4 Lines each. The camera works with full scanning, when the total effective lines of the eight partial. (VAHA [] + VAHB[] + VAHC[] + VAHD[] + VAHE[] + VAHF[] + VAHG[] + VAHH[]) is greater than 3072.
A8H: VAHE[7..0] A9H: VAHE[15..8]	[Vertical AOI Effective Line AOI_E] Initial data: VAHE[15..0] = 30、 Range: 0 to 3,072 Sets the number of the effective lines (image height) of the variable partial scanning. The value should be set 4 Lines each. The camera works with full scanning, when the total effective lines of the eight partial. (VAHA [] + VAHB[] + VAHC[] + VAHD[] + VAHE[] + VAHF[] + VAHG[] + VAHH[]) is greater than 3072.
AAH: VAHF[7..0] ABH: VAHF[15..8]	[Vertical AOI Effective Line AOI_F] Initial data: VAHF[15..0] = 0、 Range: 0 to 3,072 Sets the number of the effective lines (image height) of the variable partial scanning. The value should be set 4 Lines each. The camera works with full scanning, when the total effective lines of the eight partial. (VAHA [] + VAHB[] + VAHC[] + VAHD[] + VAHE[] + VAHF[] + VAHG[] + VAHH[]) is greater than 3072.
ACH: VAHG[7..0] ADH: VAHG[15..8]	[Vertical AOI Effective Line AOI_G] Initial data: VAHG[15..0] = 0、 Range: 0 to 3,072 Sets the number of the effective lines (image height) of the variable partial scanning. The value should be set 4 Lines each. The camera works with full scanning, when the total effective lines of the eight partial. (VAHA [] + VAHB[] + VAHC[] + VAHD[] + VAHE[] + VAHF[] + VAHG[] + VAHH[]) is greater than 3072.
AEH: VAHH[7..0] AFH: VAHH[15..8]	[Vertical AOI Effective Line AOI_H] Initial data: VAHH[15..0] = 0、 Range: 0 to 3,072 Sets the number of the effective lines (image height) of the variable partial scanning. The value should be set 4 Lines each. The camera works with full scanning, when the total effective lines of the eight partial. (VAHA [] + VAHB[] + VAHC[] + VAHD[] + VAHE[] + VAHF[] + VAHG[] + VAHH[]) is greater than 3072.

(888)687-6877
ELECTRONIC GROUP, INC
aegis-g2@aegiselect.com

Command No.	Command Descriptions
B0H: HASA[7..0] B1H: HASA[15..8]	[Horizontal AOI Start Pixel AOI_A] Initial data: HASA[15..0] = 0、 Range: 0 to 4,095 Sets Horizontal AOI Start Pixel AOI_A.
B2H: HASB[7..0] B3H: HASB[15..8]	[Horizontal AOI Start Pixel AOI_B] Initial data: HASB[15..0] = 0、 Range: 0 to 4,095 Sets Horizontal AOI Start Pixel AOI_B.
B4H: HASC[7..0] B5H: HASC[15..8]	[Horizontal AOI Start Pixel AOI_C] Initial data: HASC[15..0] = 0、 Range: 0 to 4,095 Sets Horizontal AOI Start Pixel AOI_C.
B6H: HASD[7..0] B7H: HASD[15..8]	[Horizontal AOI Start Pixel AOI_D] Initial data: HASD[15..0] = 0、 Range: 0 to 4,095 Sets Horizontal AOI Start Pixel AOI_D.
B8H: HASE[7..0] B9H: HASE[15..8]	[Horizontal AOI Start Pixel AOI_E] Initial data: HASE[15..0] = 0、 Range: 0 to 4,095 Sets Horizontal AOI Start Pixel AOI_E.
BAH: HASF[7..0] BBH: HASF[15..8]	[Horizontal AOI Start Pixel AOI_F] Initial data: HASF[15..0] = 0、 Range: 0 to 4,095 Sets Horizontal AOI Start Pixel AOI_F.
BCH: HASG[7..0] BDH: HASG[15..8]	[Horizontal AOI Start Pixel AOI_G] Initial data: HASG[15..0] = 0、 Range: 0 to 4,095 Sets Horizontal AOI Start Pixel AOI_G.
BEH: HASH[7..0] BFH: HASH[15..8]	[Horizontal AOI Start Pixel AOI_H] Initial data: HASH[15..0] = 0、 Range: : 0 to 4,095 Sets Horizontal AOI Start Pixel AOI_H.

 (888)687-6877

ELECTRONIC GROUP, INC
aegis-g2@aegiselect.com

Command No.	Command Descriptions
C0H: HAWA[7..0] C1H: HAWA[15..8]	[Horizontal AOI Effective Pixel AOI_A] Initial data: HAWA[15..0] = 4,096、 Range: 0 to 4,096 Sets the number of effective pixels (image width). The effective pixels is same as DVAL. Variable value depends on Tap number of CameraLink. When effective pixels (image width) is 0 or larger than horizontal pixels, Effective pixels (image width) = Horizontal pixels
C2H: HAWB[7..0] C3H: HAWB[15..8]	[Horizontal AOI Effective Pixel AOI_B] Initial data: HAWB[15..0] = 0、 Range: 0 to 4,096 Sets the number of effective pixels (image width). The effective pixels is same as DVAL. Variable value depends on Tap number of CameraLink. When effective pixels (image width) is 0 or larger than horizontal pixels, Effective pixels (image width) = Horizontal pixels
C4H: HAWC[7..0] C5H: HAWC[15..8]	[Horizontal AOI Effective Pixel AOI_C] Initial data: HAWC[15..0] = 0、 Range: 0 to 4,096 Sets the number of effective pixels (image width). The effective pixels is same as DVAL. Variable value depends on Tap number of CameraLink. When effective pixels (image width) is 0 or larger than horizontal pixels, Effective pixels (image width) = Horizontal pixels
C6H: HAWD[7..0] C7H: HAWD[15..8]	[Horizontal AOI Effective Pixel AOI_D] Initial data: HAWD[15..0] = 0、 Range: 0 to 4,096 Sets the number of effective pixels (image width). The effective pixels is same as DVAL. Variable value depends on Tap number of CameraLink. When effective pixels (image width) is 0 or larger than horizontal pixels, Effective pixels (image width) = Horizontal pixels
C8H: HAWE[7..0] C9H: HAWE[15..8]	[Horizontal AOI Effective Pixel AOI_E] Initial data: HAWE[15..0] = 0、 Range: 0 to 4,096 Sets the number of effective pixels (image width). The effective pixels is same as DVAL. Variable value depends on Tap number of CameraLink. When effective pixels (image width) is 0 or larger than horizontal pixels, Effective pixels (image width) = Horizontal pixels
CAH: HAWF[7..0] CBH: HAWF[15..8]	[Horizontal AOI Effective Pixel AOI_F] Initial data: HAWF[15..0] = 0、 Range: 0 to 4,096 Sets the number of effective pixels (image width). The effective pixels is same as DVAL. Variable value depends on Tap number of CameraLink. When effective pixels (image width) is 0 or larger than horizontal pixels, Effective pixels (image width) = Horizontal pixels
CCH: HAWG[7..0] CDH: HAWAG15..8]	[Horizontal AOI Effective Pixel AOI_G] Initial data: HAWG[15..0] = 0、 Range: 0 to 4,096 Sets the number of effective pixels (image width). The effective pixels is same as DVAL. Variable value depends on Tap number of CameraLink. When effective pixels (image width) is 0 or larger than horizontal pixels, Effective pixels (image width) = Horizontal pixels
CEH: HAWH[7..0] CFH: HAWH[15..8]	[Horizontal AOI Effective Pixel AOI_H] Initial data: HAWH[15..0] = 0、 Range: 0 to 4,096 Sets the number of effective pixels (image width). The effective pixels is same as DVAL. Variable value depends on Tap number of CameraLink. When effective pixels (image width) is 0 or larger than horizontal pixels, Effective pixels (image width) = Horizontal pixels

(888)687-6877
 ELECTRONIC GROUP, INC
aegis-g2@aegiselect.com

Command No.	Command Descriptions								
DEH: DEF_M[7..0]	<p>[Pixel defect correction mode1] Initial data: DEF_M [7..0] = 1 Sets the pixel defect correction. As for the x-y coordinate of defect pixel, please refer to the Device Code:3AH</p> <table border="1"> <tr> <td>D7</td><td>D6</td><td>D5</td><td>D4</td><td>D3</td><td>D2</td><td>D1</td><td>D0</td> </tr> </table> <p>D7 to D4: Upper Address 0 to 9 D3 to D2: No Function Always set as "00" D1: Highlight the corrected pixel 0: <u>Disable</u> 1: <u>Enable</u> D0: Pixel Defect Correction 0: <u>Disable</u> 1: <u>Enable</u></p> <p>When Highlight the corrected pixel is Enable, corrected pixel appeared with highlight. ※D7 to D4 is Device Code : to set the X-Y coordinate of defect pixel with 3AH.</p>	D7	D6	D5	D4	D3	D2	D1	D0
D7	D6	D5	D4	D3	D2	D1	D0		
DFH: DEF_M2[7..0]	<p>[Pixel defect correction mode 2] Initial data : DEF_M2[7..0] = 70H Sets the artificial effect with pixel defect correction.</p> <table border="1"> <tr> <td>D7</td><td>D6</td><td>D5</td><td>D4</td><td>D3</td><td>D2</td><td>D1</td><td>D0</td> </tr> </table> <p>D7: No Function Always set as "0" D6: AOI 0: <u>Disable</u> 1: <u>Enable</u> D5: Vertical Flip 0: <u>Disable</u> 1: <u>Enable</u> D4: Horizontal Flip 0: <u>Disable</u> 1: <u>Enable</u> D3 to D0: No Function Always set as "0000"</p> <p>※As for the x-y coordinate of defect pixel, please refer to the Device Code:3AH</p>	D7	D6	D5	D4	D3	D2	D1	D0
D7	D6	D5	D4	D3	D2	D1	D0		
E3H: FPN[7..0]	<p>[FPN Correction Mode] Initial data: FPN[7..0] = 1 Sets the FPN Correction (※FPN : Fixed Pattern Noise)</p> <table border="1"> <tr> <td>D7</td><td>D6</td><td>D5</td><td>D4</td><td>D3</td><td>D2</td><td>D1</td><td>D0</td> </tr> </table> <p>D7 to D1: No Function Always set as "0000000" D0: FPN Correction Mode 0: <u>Disable</u> 1: <u>Enable</u></p>	D7	D6	D5	D4	D3	D2	D1	D0
D7	D6	D5	D4	D3	D2	D1	D0		
EEH: MOD6[7..0] EFH MOD6[15..8]	<p>[The camera function mode] Initial data: MOD6 [7..0] = 0 Sets the camera TAP number for each setting</p> <p>D15 to D0: TAP Number</p> <p>0: 2 TAP 1: 4 TAP 2: 8 TAP 3: 10 TAP 4-15: No function 16: 3 TAP More than 17: No function</p>								

(888)687-6877
ELECTRONIC GROUP, INC
aegis-g2@aegiselect.com

6.4.3 Camera Control Command list (Device Code:3AH)

The actual 256points of Pixel Blemish Correction (PB Correction) Values are stored on this address.

600points

The data size of each Command No. is 1 Byte(8bit)

"EEPROM" on the table shows the access on EEPROM

(○: can be saved on EEPROM, ×: can not be saved on EEPROM)

At the shipping time, defect pixel were corrected and stored the information into EEPROM for each camera. When the rest of point still exist, FFFFh will be stored as initial data on X,Y Point. User can use these parameters

These values will be initialized as saved EEPROM data when camera turned on.

Device Code : 3AH (Device Code 00H DEh[7..4] = 0)

Command No.	R/W	EEPROM	Function	Initial Data	Data Range
00H	R/W	○	X1 point of PB Correction (16bit : D[7..0])	FFFFh (PB Correction OFF)	0 to 4095
01H	R/W	○	X1 point of PB Correction (16bit : D[15..8])		
02H	R/W	○	Y1 point of PB Correction (16bit : D[7..0])	FFFFh (PB Correction OFF)	0 to 3071
03H	R/W	○	Y1 point of PB Correction (16bit : D[15..8])		
to					
FCH	R/W	○	X64 point of PB Correction (16bit : D[7..0])	FFFFh (PB Correction OFF)	0 to 4095
FDH	R/W	○	X64 point of PB Correction (16bit : D[15..8])		
FEH	R/W	○	Y64 point of PB Correction (16bit : D[7..0])	FFFFh (PB Correction OFF)	0 to 3071
FFH	R/W	○	Y64 point of PB Correction (16bit : D[15..8])		

Device Code : 3AH (Device Code 00H DEh[7..4] = 1)

Command No.	R/W	EEPROM	Function	Initial Data	Data Range
00H	R/W	○	X65 point of PB Correction (16bit : D[7..0])	FFFFh (PB Correction OFF)	0 to 4095
01H	R/W	○	X65 point of PB Correction (16bit : D[15..8])		
02H	R/W	○	Y65 point of PB Correction (16bit : D[7..0])	FFFFh (PB Correction OFF)	0 to 3071
03H	R/W	○	Y65 point of PB Correction (16bit : D[15..8])		
to					
FCH	R/W	○	X128 point of PB Correction (16bit : D[7..0])	FFFFh (PB Correction OFF)	0 to 4095
FDH	R/W	○	X128 point of PB Correction (16bit : D[15..8])		
FEH	R/W	○	Y128 point of PB Correction (16bit : D[7..0])	FFFFh (PB Correction OFF)	0 to 3071
FFH	R/W	○	Y128 point of PB Correction (16bit : D[15..8])		

(888)687-6877
 ELECTRONIC GROUP, INC
aegis-g2@aegiselect.com

Device Code : 3AH (Device Code 00H DEh[7..4] = 2)

Command No.	R/W	EEPROM	Function	Initial Data	Data Range
00H	R/W	○	X129 point of PB Correction (16bit : D[7..0])	FFFFh	0 to 4095
01H	R/W	○	X129 point of PB Correction (16bit : D[15..8])	(PB Correction OFF)	
02H	R/W	○	Y129 point of PB Correction (16bit : D[7..0])	FFFFh	0 to 3071
03H	R/W	○	Y129 point of PB Correction (16bit : D[15..8])	(PB Correction OFF)	
to					
1CH	R/W	○	X192 point of PB Correction (16bit : D[7..0])	FFFFh	0 to 4095
1DH	R/W	○	X192 point of PB Correction (16bit : D[15..8])	(PB Correction OFF)	
1EH	R/W	○	Y192 point of PB Correction (16bit : D[7..0])	FFFFh	0 to 3071
1FH	R/W	○	Y192 point of PB Correction (16bit : D[15..8])	(PB Correction OFF)	

Device Code : 3AH (Device Code 00H DEh[7..4] = 3)

Command No.	R/W	EEPROM	Function	Initial Data	Data Range
00H	R/W	○	X193 point of PB Correction (16bit : D[7..0])	FFFFh	0 to 4095
01H	R/W	○	X193 point of PB Correction (16bit : D[15..8])	(PB Correction OFF)	
02H	R/W	○	Y193 point of PB Correction (16bit : D[7..0])	FFFFh	0 to 3071
03H	R/W	○	Y193 point of PB Correction (16bit : D[15..8])	(PB Correction OFF)	
to					
FCH	R/W	○	X256 point of PB Correction (16bit : D[7..0])	FFFFh	0 to 4095
FDH	R/W	○	X256 point of PB Correction (16bit : D[15..8])	(PB Correction OFF)	
FEH	R/W	○	Y256 point of PB Correction (16bit : D[7..0])	FFFFh	0 to 3071
FFH	R/W	○	Y256 point of PB Correction (16bit : D[15..8])	(PB Correction OFF)	

Device Code : 3AH (Device Code 00H DEh[7..4] = 4)

Command No.	R/W	EEPROM	Function	Initial Data	Data Range
00H	R/W	○	X193 point of PB Correction (16bit : D[7..0])	FFFFh	0 to 4095
01H	R/W	○	X193 point of PB Correction (16bit : D[15..8])	(PB Correction OFF)	
02H	R/W	○	Y193 point of PB Correction (16bit : D[7..0])	FFFFh	0 to 3071
03H	R/W	○	Y193 point of PB Correction (16bit : D[15..8])	(PB Correction OFF)	
to					
FCH	R/W	○	X256 point of PB Correction (16bit : D[7..0])	FFFFh	0 to 4095
FDH	R/W	○	X256 point of PB Correction (16bit : D[15..8])	(PB Correction OFF)	
FEH	R/W	○	Y256 point of PB Correction (16bit : D[7..0])	FFFFh	0 to 3071
FFH	R/W	○	Y256 point of PB Correction (16bit : D[15..8])	(PB Correction OFF)	

(888)687-6877
ELECTRONIC GROUP, INC
aegis-g2@aegiselect.com

Device Code : 3AH (Code 00H DEh[7..4] = 5)

Command No.	R/W	EEPROM	Function	Initial Data	Data Range
00H	R/W	○	X321 point of PB Correction (16bit : D[7..0])	FFFFh	0 to 4095
01H	R/W	○	X321 point of PB Correction (16bit : D[15..8])	(PB Correction OFF)	
02H	R/W	○	X321 point of PB Correction (16bit : D[7..0])	FFFFh	0 to 3071
03H	R/W	○	X321 point of PB Correction (16bit : D[15..8])	(PB Correction OFF)	
FCH	R/W	○	X384 point of PB Correction (16bit : D[7..0])	FFFFh	0 to 4095
FDH	R/W	○	X384 point of PB Correction (16bit : D[15..8])	(PB Correction OFF)	
FEH	R/W	○	X384 point of PB Correction (16bit : D[7..0])	FFFFh	0 to 3071
FFH	R/W	○	X384 point of PB Correction (16bit : D[15..8])	(PB Correction OFF)	

Device Code : 3AH (Device Code 00H DEh[7..4] = 6)

Command No.	R/W	EEPROM	Function	Initial Data	Data Range
00H	R/W	○	X389 point of PB Correction (16bit : D[7..0])	FFFFh	0 to 4095
01H	R/W	○	X389 point of PB Correction (16bit : D[15..8])	(PB Correction OFF)	
02H	R/W	○	X389 point of PB Correction (16bit : D[7..0])	FFFFh	0 to 3071
03H	R/W	○	X389 point of PB Correction (16bit : D[15..8])	(PB Correction OFF)	
FCH	R/W	○	X448 point of PB Correction (16bit : D[7..0])	FFFFh	0 to 4095
FDH	R/W	○	X448 point of PB Correction (16bit : D[15..8])	(PB Correction OFF)	
FEH	R/W	○	X448 point of PB Correction (16bit : D[7..0])	FFFFh	0 to 3071
FFH	R/W	○	X448 point of PB Correction (16bit : D[15..8])	(PB Correction OFF)	

Device Code : 3AH (Device Code 00H DEh[7..4] = 7)

Command No.	R/W	EEPROM	Function	Initial Data	Data Range
00H	R/W	○	X449 point of PB Correction (16bit : D[7..0])	FFFFh	0 to 4095
01H	R/W	○	X449 point of PB Correction (16bit : D[15..8])	(PB Correction OFF)	
02H	R/W	○	X449 point of PB Correction (16bit : D[7..0])	FFFFh	0 to 3071
03H	R/W	○	X449 point of PB Correction (16bit : D[15..8])	(PB Correction OFF)	
FCH	R/W	○	X512 point of PB Correction (16bit : D[7..0])	FFFFh	0 to 4095
FDH	R/W	○	X512 point of PB Correction (16bit : D[15..8])	(PB Correction OFF)	
FEH	R/W	○	X512 point of PB Correction (16bit : D[7..0])	FFFFh	0 to 3071
FFH	R/W	○	X512 point of PB Correction (16bit : D[15..8])	(PB Correction OFF)	

(888)687-6877
ELECTRONIC GROUP, INC
aegis-g2@aegiselect.com

Device Code : 3AH (Device Code 00H DEh[7..4] = 8)

Command No.	R/W	EEPROM	Function	Initial Data	Data Range
00H	R/W	○	X513 point of PB Correction (16bit : D[7..0])	FFFFh	0 to 4095
01H	R/W	○	X513 point of PB Correction (16bit : D[15..8])	(PB Correction OFF)	
02H	R/W	○	X513 point of PB Correction (16bit : D[7..0])	FFFFh	0 to 3071
03H	R/W	○	X513 point of PB Correction (16bit : D[15..8])	(PB Correction OFF)	
~					
FCH	R/W	○	X576 point of PB Correction (16bit : D[7..0])	FFFFh	0 to 4095
FDH	R/W	○	X576 point of PB Correction (16bit : D[15..8])	(PB Correction OFF)	
FEH	R/W	○	X576 point of PB Correction (16bit : D[7..0])	FFFFh	0 to 3071
FFH	R/W	○	X576 point of PB Correction	(PB Correction OFF)	

Device Code : 3AH (Device Code 00H DEh[7..4] = 9)

Command No.	R/W	EEPROM	Function	Initial Data	Data Range
00H	R/W	○	X577 point of PB Correction (16bit : D[7..0])	FFFFh	0 to 4095
01H	R/W	○	X577 point of PB Correction (16bit : D[15..8])		
02H	R/W	○	X577 point of PB Correction (16bit : D[7..0])	FFFFh	0 to 3071
03H	R/W	○	X577 point of PB Correction (16bit : D[15..8])		
~					
5CH	R/W	○	X600 point of PB Correction (16bit : D[7..0])	FFFFh	0 to 4095
5DH	R/W	○	X600 point of PB Correction (16bit : D[15..8])		
5EH	R/W	○	X600 point of PB Correction (16bit : D[7..0])	FFFFh	0 to 3071
5FH	R/W	○	X600 point of PB Correction (16bit : D[15..8])		

Aegis Electronic Group, Inc.

(888)687-6877
 ELECTRONIC GROUP, INC
aegis-g2@aegiselect.com

Sequence for the command saves to the EEPROM

Please use below sequence for the command saves to the EEPROM

- 1) Set "1" to the 80H.0 for the accept "write control to the EEPROM".
- 2) Send the command and the save data with the EEPROM access command, which is set "1" for the page selection.
- 3) The camera send back the one of the below receiving code after write EEPROM.
 - 01H: OK
 - 10H: EEPROM write error
- 4) 80H.0 is changed to "0" automatically after write EEPROM.

Note.1) DO NOT saves to the EEPROM when 80H.0 is "0".

Note.2) When save the multiple sequence command to the EEPROM, all data save to the EEPROM by one operation from 1) to 4).

Example of the multiple sequence command: "10H, 11H, 12H and 13H" or "22H, 23H and 24H".

Note.3) When save the multiple command data, which is not sequence command, to the EEPROM, it is necessary to operate the number of times from 1) to 4).

Example of the multiple command: "10H, 13H, 19H and 1BH" or "20H, 23H and 25H".

Aegis Electronic Group, Inc.

Aegis (888)687-6877
ELECTRONIC GROUP, INC
aegis-g2@aegiselect.com

8 Control Software

8.1 Summary

After installing the control software and launch the CLCtrl2.exe, main window appears as below.

Menu
As for the detail, please refer to the next page.

Camera Setting Parameters
As for the detail, please refer to the next chapter **SOFTWARE FUNCTION(STANDARD)**.

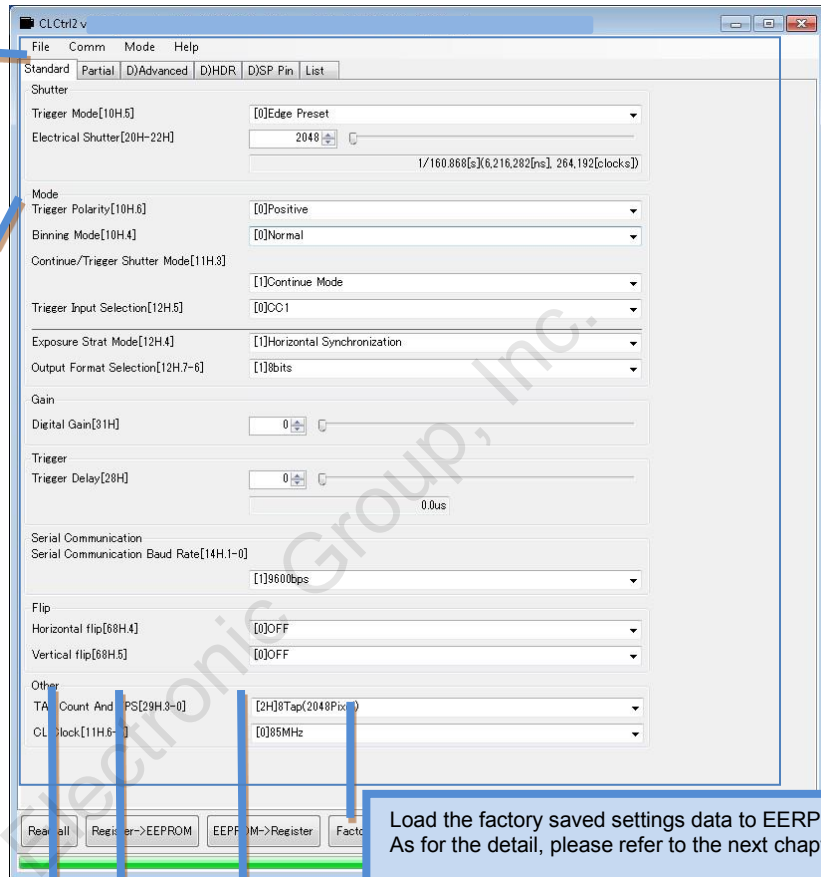

Load the factory saved settings data to EERPOM .
As for the detail, please refer to the next chapter **COMM**.

Load the previously saved settings data from EERPOM to Register.
As for the detail, please refer to the next chapter **COMM**.

Save
As for

Read the ca
As for the d

Aegis (888)687-6877
ELECTRONIC GROUP, INC
aegis-g2@aegiselect.com

8.1.1 File

Open[From File to Register]

Open the camera setting file (.i2c).

Save as[From Register to File]

Save the current camera setting data on the register to the PC as i2c file.

Open[From File to EEPROM]

Open the camera setting file (.i2c) that is read at power on.

Save as[From EEPROM to File]

Save the camera setting data on EEPROM to the PC as i2c file.

Quit

Exit the control software.

8.1.2 Comm

Port Setting

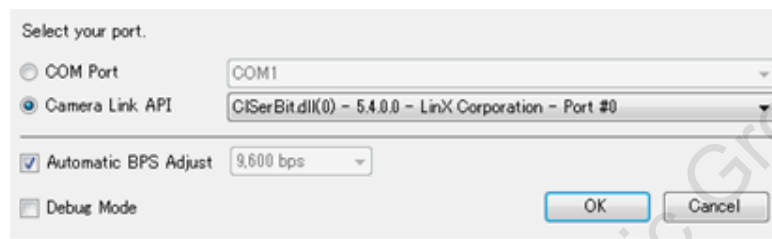

[Select your port]

COM port

When the Graber Board support COM port, Please select this comand.

Camera Link API

When the Graber Board supports Camera Link API, Please select this comand.

[Automatic BPS Adjust]

Select the serial communication speed automatically. When un-checked the box, communication speed can be selected.

[Debug Mode]

Basically un-checked the box, when checked the box, transfer data can be monitored through 3rd party software.

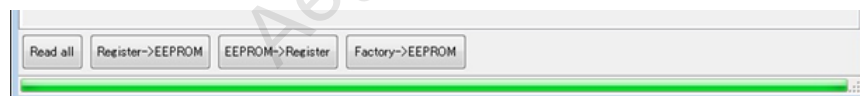

Read all

Read the setting of all data from camera register. This setting data on the register cannot be saved without saving the EEPROM(**Registe** -----)

Register -> EEPROM

Save the register data into the EEPROM on the c

EEPROM -> Register

Read the EEPROM data into the register. When

Factory -> EEPROM

Restore the factory setting data from EEPROM t

8.1.3 Mode

Language

Select the language from English, Japanese.

(888)687-6877
ELECTRONIC GROUP, INC
aegis-g2@aegiselect.com

8.1.4 Help

Advanced Operation

When password(sentechcamera) is input, additional functions appear for power user. SP Pin tab can be used.

Version Information

Software information window appear.

8.2 Software Function(Standard)

This tab has basic camera function. the number(like [10H.5]) beside of the function is register address. When direct register access is needed. Please refer to the [6.THE COMMUNICATION PROTOCOL SPECIFICATIONS.](#)

8.2.1 Shutter

Trigger

Mode

Edge Preset The camera exposure starts at the rising (or falling) edge of the trigger pulse. Exposure duration time is preset.

Pulse Width The camera exposure starts at the rising (or falling)edge of the trigger pulse and stops at the falling(or rising) edge of the trigger pulse.

As for the detail of Trigger Mode, please refer to the [5.CAMERA FUNCTION MODES.](#)

Electrical Shutter

Effectrical shutter setting can be set through the slide ba or set through the actual register value. Actual exposure time appears on the bottom of the slide bar.

As for the detail of exposure time setting, please refer to the[6.THE COMMUNICATION PROTOCOL SPECIFICATIONS.](#)

(888)687-6877
ELECTRONIC GROUP, INC
aegis-g2@aegiselect.com

8.2.2 Mode

Mode	
Trigger Polarity[10H.6]	[0]Positive
Binning Mode[10H.4]	[0]Normal
Continue/Trigger Shutter Mode[11H.3]	[1]Continue Mode
Trigger Input Selection[12H.5]	[0]CC1
Exposure Strat Mode[12H.4]	[1]Horizontal Synchronization
Output Format Selection[12H.7-6]	[1]8bits

Trigger Polarity
Positive Positive signal

is available as Trigger
Negative Negative signal is available as Trigger

Binning Mode

Normal Disable the binning
Binning Enable the binning. As for the actual procedure, please refer to the **Binning[2AH.5-4], Sub[2AH.1-0]**. Averaged pixel data make decreasing the noise level. As for the detail of setting, please refer to the **8.2.6.OTHER**.

Continue/Trigger Shutter Mode

Continue Mode Obtaining the image from the camera automatically. The trigger is generated inside of the camera continuously.

Trigger Shutter Mode Obtaining the image from the external trigger timing. When this mode is selected, **Edge Preset, Pulse Width** on the [Trigger Mode] are available.

As for the detail of Continue Mode, Trigger Shutter Mode, please refer to the **5.CAMERA FUNCTION MODES**.

Trigger Input Selection

CC1: Trigger signal input from camera link connector on pin CC1.

SP4: Trigger signal input from I/O port. As for the detail, please refer to the **9.1.USING THE TRIGGER SIGNAL THROUGH 6PIN**.

Exposure Start Mode

Normal : Exposure is going to start after trigger input. The exposure can start during the video out from the camera with horizontal noises.

Horizontal Synchronization The exposure can start during the video out from the camera without horizontal noises. The maximum delay to start exposure from the trigger inputs in 1H.

Output Format Selection. Video output bit can be selected from 8/10/12 bit. Video output bit is different for each mode. As for the relation of mode to video output, please refer to the **4.2**.

Aegis (888)687-6877
ELECTRONIC GROUP, INC
aegis-g2@aegiselect.com

8.2.3 Gain

Gain	
Digital Gain[31H]	0

Digital Gain

The value of digital gain.As for the detail of gain calucuration, please refer to the [31H](#).

Trigger

Trigger	
Trigger Delay[28H]	0
	0.0us

Trigger

Delay

The delay time for the trigger.. As for the detail of delay time calculation, please refer to the [28H](#).

8.2.4 Serial Communication

Serial Communication	
Serial Communication Baud Rate[14H.1-0]	[1]9600bps

Serial Communication Baud Rate

Baud rate can be selected.

8.2.5 Flip

Flip	
Horizontal flip[68H.4]	[0]OFF
Vertical flip[68H.5]	[0]OFF

Horizontal flip

OFF Normal image
ON Horizontal Mirror image

Vertical flip

OFF Normal image
ON Vertical Mirror image

8.2.6 Other

Other	
TAP Count And FPS[29H.3-0]	[2H]8Tap(2048Pixel)
CL Clock[11H.6-5]	[0]85MHz

And FPS

TAP number can be selected by frame rate, Ca please refer to the [4.2](#).

⋮

(888)687-6877
ELECTRONIC GROUP, INC
aegis-g2@aegiselect.com

8.3 Software Function (Partial)

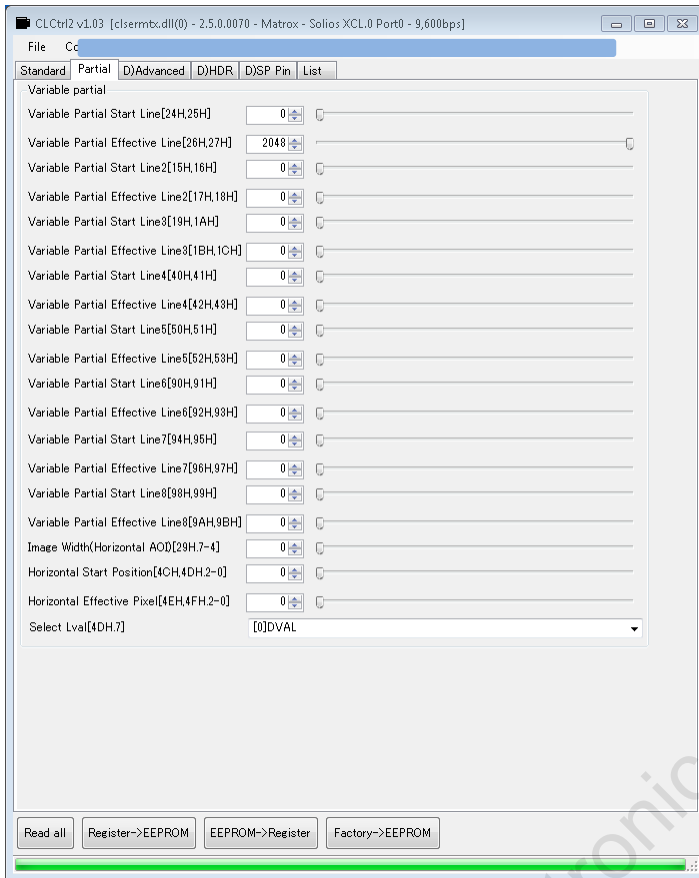

Variable partial

Partial scan can be set. As for the detail please refer to [6.THE COMMUNICATION PROTOCOL SPECIFICATIONS.](#)

8.4 Software Function Advanced)

This tab is used for factory setting. Please do not use this tab.

8.5 Software Function (HDR)

This tab uses for the power user to control the Gamma deeply. Do not use the color model.

8.6 Software Function (SP Pin)

External trigger can be used. As for the detail, please refer to the [9.1. USING THE TRIGGER SIGNAL THROUGH 6PIN.](#)

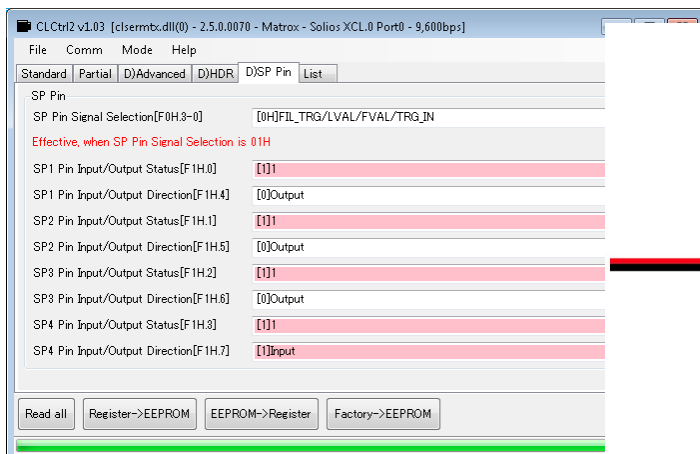

Aegis (888)687-6877
 ELECTRONIC GROUP, INC
 aegis-g2@aegiselect.com

9 Actual Camera Setting & Technical Notes

9.1 Using the Trigger Signal through 6pin

1. Select the "[0]Trigger Shutter Mode(Long Exposure)" on Contiue/Trigger Shutter Mode Selection at Standard tab through the control software(CLCtrl2).
2. Select the "[0H] FIL_TRG/LVAL/FVAL_TRG_IN" on SP Pin Signal Selection at SP_Pin tab.
3. Input the trigger signal through Pin2. As for using the software, please refer to the 7.

CONTROL Software.

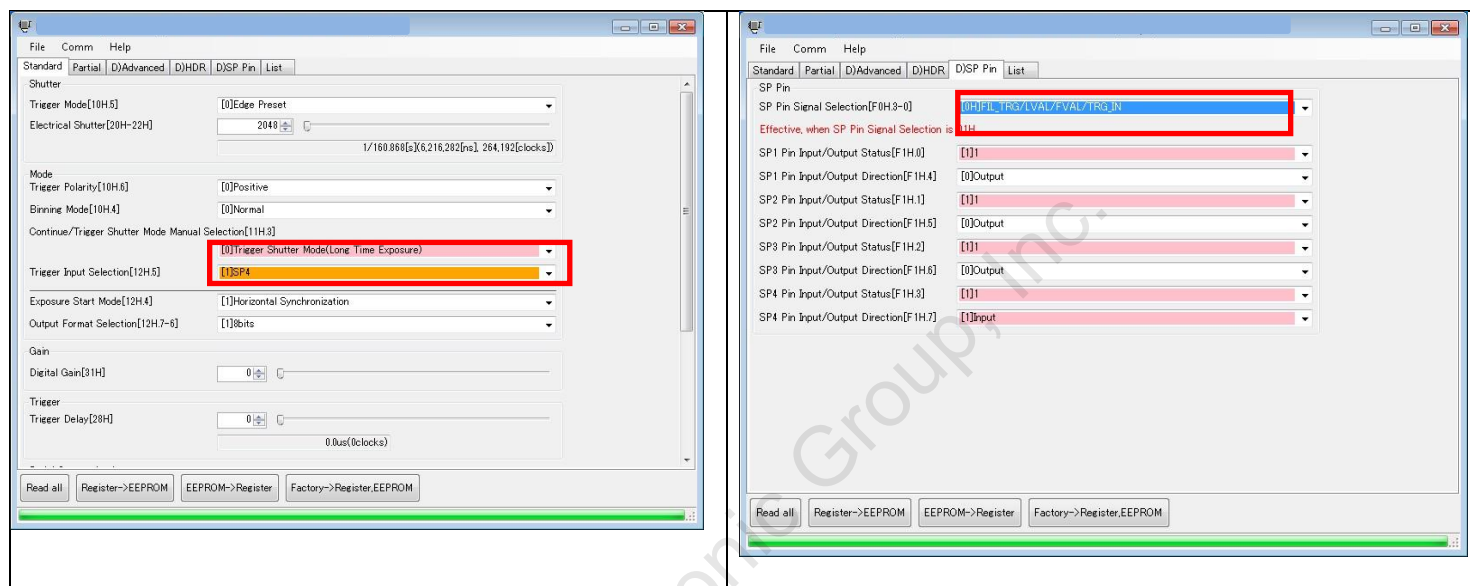

SP Pin Signal Selection Table

Pin No	5	4	3	2
Addr=F0	SP1	SP2	SP3	SP4
0	AfterTrigger FILTER	LVAL	FVAL	Trigger Input
1	F1h.0	F1h.1	F1h.2	F1h.3
2	After Trigger FILTER	HIGH in exposure	LOW in exposure	Trigger Input
7	LVAL	CC1	HIGH in Exposure	FVAL
Others	Reserved			

(888)687-6877
 ELECTRONIC GROUP, INC
aegis-g2@aegiselect.com

10 Revision History

Revisions

Rev	Date	Changes	Note
00	2014/01/20	Released as Production model	
01	2014/07/01	Revised Company name Support 10,8,4,3,2TAP model Revised Aluminum (AC) to Aluminum alloy Revised ROI information	
02	2014/09/03	Revised Formula on Shutter Speed(20H)	
03	2014/10/06	Revised Information on 11H,4CH,4DH,56H,57H,5BH,5CH,A2-AFH,EEH,DEH	
04	2014/11/28	Revised Minimum scene illumination and Shutter speed	
05	2014/12/12	Revised Power Consumption on Base Configuration	
06	2015/01/20	Revised Noise level, description on 12bit output, and arranged form on "Description of the camera control commands"	
07	2015/10/05	Revised Horizontal Blanking Timing	
08	2015/11/19	Revised Standard compliancy	
09	2017/06/21	Revised: Added Product Precautions, Product Warranty	
10	2017/07/03	Revised: Change the name of company	
11	2017/07/28	Revised: Added Mount information on Naming Method	

Aegis Electronic Group, Inc.

Aegis (888)687-6877
ELECTRONIC GROUP, INC
aegis-g2@aegiselect.com

Aegis Electronic Group, Inc.

Aegis (888)687-6877
ELECTRONIC GROUP, INC
aegis-g2@aegiselect.com