

GigE Vision

Color / Monochrome CMOS PoE Camera

STC-SBA503POE (5M / Monochrome)

STC-SCA503POE (5M / Color)

Product Specifications and User's Guide

Aegis Electronic Group, Inc.

OMRON SENTECH CO., LTD.

Table of Contents

| | | |
|----------|--|-----------|
| 1 | Product Precautions | 7 |
| 2 | Warranty | 7 |
| 3 | Introduction | 8 |
| 3.1 | Features | 8 |
| 3.2 | Product Number Naming Method | 8 |
| 4 | Specifications | 9 |
| 4.1 | Electronic Specifications..... | 9 |
| 4.2 | Spectral Sensitivity Characteristics | 11 |
| 4.2.1 | STC-SBA503POE | 11 |
| 4.2.2 | STC-SCA503POE | 11 |
| 4.2.3 | IR Cut Filter (STC-SCA503POE) | 12 |
| 4.3 | Mechanical Specifications..... | 13 |
| 4.4 | Environmental Specifications | 13 |
| 5 | Connector Specifications | 14 |
| 5.1 | RJ45 Connector..... | 14 |
| 5.2 | Power and Control Signal Connector..... | 15 |
| 5.2.1 | Equivalent Circuit for the Input Pin of the I/O Connector..... | 17 |
| 5.2.2 | Typical Input Circuit..... | 18 |
| 5.2.3 | Typical Output Circuit..... | 19 |
| 5.2.4 | Input and Output Signal Timing (Hardware Trigger)..... | 20 |
| 5.2.5 | Input and Output Signal Timing (Software Trigger)..... | 21 |
| 6 | Dimensions | 22 |
| 6.1 | STC-SBA503POE..... | 22 |
| 6.2 | STC-SCA503POE..... | 23 |
| 7 | Sensor information | 24 |

| | | |
|----------|--|-----------|
| 7.1 | Pixel Transferring Image..... | 24 |
| 8 | Camera Operational Modes | 25 |
| 8.1 | Normal Mode (TriggerMode = Off)..... | 25 |
| 8.2 | Pulse width trigger mode (ExposureMode = TriggerWidth) | 25 |
| 8.2.1 | Timing..... | 25 |
| 8.2.2 | Exposure Timing with the Positive Polarity Trigger Signal..... | 26 |
| 8.2.3 | Exposure Timing with the Negative Polarity Trigger Signal | 26 |
| 8.3 | Edge Preset Trigger Mode (ExposureMode = Timed)..... | 27 |
| 8.3.1 | Timing..... | 27 |
| 8.3.2 | Exposure Timing with the Positive Polarity Trigger Signal..... | 28 |
| 8.3.3 | Exposure Timing with the Negative Polarity Trigger signal..... | 28 |
| 8.4 | Edge Preset Trigger Mode (Trigger Input While the Image Is Out)..... | 29 |
| 8.4.1 | Timing..... | 29 |
| 8.5 | CMOS Rest Type..... | 30 |
| 9 | Camera Functions | 31 |
| 9.1 | ROI (Region of Interest) | 31 |
| 9.1.1 | ROI (1 region)..... | 31 |
| 9.2 | Pixel Format..... | 33 |
| 9.3 | Binning..... | 33 |
| 9.4 | Decimation (Skipping)..... | 34 |
| 9.5 | Image Flip..... | 35 |
| 9.6 | Gain | 37 |
| 9.6.1 | Analog gain | 37 |
| 9.6.2 | Digital gain | 37 |
| 9.7 | Black level..... | 37 |
| 9.8 | ALC (Auto Light Control)..... | 38 |
| 9.8.1 | ALC control method..... | 39 |
| 9.8.2 | AGC (Auto Gain Control)..... | 39 |
| 9.8.3 | Auto shutter | 40 |
| 9.8.4 | ALC settings procedure | 40 |
| 9.9 | White balance (Only available for the color cameras) | 41 |
| 9.9.1 | White balance control methods | 41 |

| | | |
|-----------|--|-----------|
| 9.9.2 | OFF | 42 |
| 9.9.3 | Auto white balance | 42 |
| 9.9.4 | Push to set white balance | 42 |
| 9.9.5 | Preset white balance1 to 3 | 43 |
| 9.9.6 | White balance calculate area setting | 44 |
| 9.10 | Gamma correction..... | 45 |
| 9.10.1 | Gamma table writing..... | 45 |
| 9.11 | Save and load the camera setting data | 46 |
| 9.11.1 | The camera settings saving | 46 |
| 9.11.2 | The camera settings loading..... | 47 |
| 9.11.3 | The camera settings loading when the camere power is on. | 47 |
| 9.11.4 | The camera settings initialization..... | 47 |
| 9.12 | Trigger | 48 |
| 9.12.1 | Trigger signal processing procedure | 48 |
| 9.13 | The camera settings (GenICam parameters) control with SDK..... | 49 |
| 9.13.1 | Integer type parameter control | 49 |
| 9.13.2 | Float type parameter control..... | 49 |
| 9.13.3 | Enumeration type parameter control | 49 |
| 9.13.4 | String type paramter control..... | 50 |
| 9.13.5 | Boolean type parameter control | 50 |
| 9.13.6 | Command type paramter control..... | 50 |
| 9.14 | GenICam Command List..... | 51 |
| 9.14.1 | DeviceControl | 51 |
| 9.14.2 | ImageFormatControl..... | 51 |
| 9.14.3 | AcquisitionControl | 52 |
| 9.14.4 | DigitalIOControl | 52 |
| 9.14.5 | CounterAndTimerControl..... | 53 |
| 9.14.6 | EventControl | 53 |
| 9.14.7 | AnalogControl..... | 53 |
| 9.14.8 | TransportLayerControl | 54 |
| 9.14.9 | UserSetControl | 55 |
| 9.14.10 | IPEngine | 55 |
| 9.14.11 | SpecialFeatures | 56 |
| 10 | Revision History | 58 |

Precautions for safe use

Please read carefully this "Precautions for safe use" before use the camera. Then the camera uses correctly with agreeing with below notes.

In this "Precautions for safe use", notes divides into "Warning" and "Caution" to use the camera safety and prevent to harm and damage.

| | |
|----------------|---|
| Warning | This shows, assumption for possibility of serious accident leading death or serious injury if ignore this note and camera uses incorrectly. |
| Caution | This shows, assumption for possibility of bear the damage or physical damage if ignore this note and camera uses incorrectly. |

About Graphic symbols



This symbol shows general prohibition.







This symbol shows completion or instruction.

[Environment / condition]









| | |
|--|--|
| Warning | |
| Do not use flammable or explosiveness atmospheres. This will cause of personal injury or fire. | Do not use for "safety for human body" related usage. This camera is designed for use "do not harm human body immediately" if by any chance the camera has malfunction. |
| Caution | |
| Use and store under specified environmental conditions (Vibration, shock, temperature, humidity) in the specifications for this camera. This will cause of fire or damage the camera. | |

[Installation and cable wiring]



| | |
|---|---|
| Warning | |
| Do not use with out of power voltage range that is specified in the specifications for this camera. This will cause of fire, electrification or malfunction. | Do not wrong wiring. This will cause of fire or malfunction. |

|  Caution | |
|---|--|
|  The camera housing is not connecting to 0 V line of camera inside circuit. There is a risk of short circuit between camera inside circuit and frame ground through other devices. This will cause of malfunction. |  It is necessary to wiring and mounting that is specified in the specifications for this camera. This will cause of fire or malfunction. |
|  It is necessary to wiring with turn off the camera. This will cause of electrification or malfunction. |  It is necessary to mounting the camera without stress for the cable. This will case of electrification or fire. |



[Usage instruction]

|  Warning | |
|--|---|
|  Do not touch the terminal and PCB board While turn on the camera. This will cause of electrification or accident caused by malfunction. |  Do not put combustibles near the camera. This will cause of fire. |
|  Do not use without usage that is specified in the specifications for this camera. This will cause of personal injury or malfunction. |  Do not push metals including screw driver into radiation holes. This will cause of electrification or malfunction. |
|  Caution | |
|  Do not push contamination into opening of the camera. This will cause of electrification or malfunction. |  Do not block the radiation holes. This will cause of fire due to increase the camera inside temperature. |

[Maintenance]

|  Caution | |
|--|---|
|  Do not disassemble or repair the camera. This will cause of fire, electrification or malfunction. |  It is turn off the camera when maintaining or inspecting the camera. This will cause of electrification. |

[Disposal]

|  Caution | |
|---|--|
|  It is necessary to dispose as industrial waste. | |

1 Product Precautions

- Do not give shock to the camera.
 - Do not haul or damage the camera cable.
 - Do not wrap the camera with any material while using the camera. This will cause the internal camera temperature to increase.
 - When the camera moving or using the place that temperature difference is extreme, countermeasure for dew condensation (heat removal / cold removal) is necessary.
 - While the camera is not using, keep the lens cap on the camera to prevent dust or contamination from getting in the sensor or filter and scratching or damaging it.
- Do not keep the camera under the following conditions.
- In wet, moist, high humidity or dusty place
 - Under direct sunlight
 - In extreme high or low temperature place
 - Near an object that releases a strong magnetic or electric field
 - Place with strong vibrations
- Apply the power that satisfies the specified in specifications for the camera.
 - The defective pixels may appear due to the sensor characteristics.
 - Use below recommend materials (or equivalent materials) to clean the surface of glass.
 - Air dust: Non Freon air duster (NAKABAYASHI Co., LTD.)
 - Alcohol: Propan-2-ol (SAN'EI KAKO Co., LTD.)
 - Non-woven: nikowipe clean room (NKB)
 - Use a soft cloth to clean the camera.

2 Warranty

■ Warranty period

One year after delivery (However, the camera had malfunction with camera uses correctly)

In below case for a fee even within warranty period.

- The malfunction caused by incorrect usage, incorrect modify or repair.
- The malfunction caused by external shock including the camera dropping after delivery the camera.
- The malfunction caused by fire, earthquake, flood disaster, thunderbolt struck, other natural disaster or wrong voltage.

■ Warranty coverage

Exchange or repair the malfunction camera if the malfunction is occurred by our responsibility.

“Warranty” mean is warranty for the delivered camera itself. Please accept the induction damage by the camera malfunction is not included.

3 Introduction

This document describes the specification of the following cameras:

STC-SBA503POE / STC-SCA503POE

3.1 Features

- Support PoE (Power over Ethernet Support)
- Maximum Frame Rate (Full Scanning): 14 fps @ 5M 8bits
- CMOS (Rolling Shutter / Global Reset)
- Defective Pixel Correction up to 64 points
- 8bits, 10bits or 12bits output

3.2 Product Number Naming Method

STC-SxA503POE

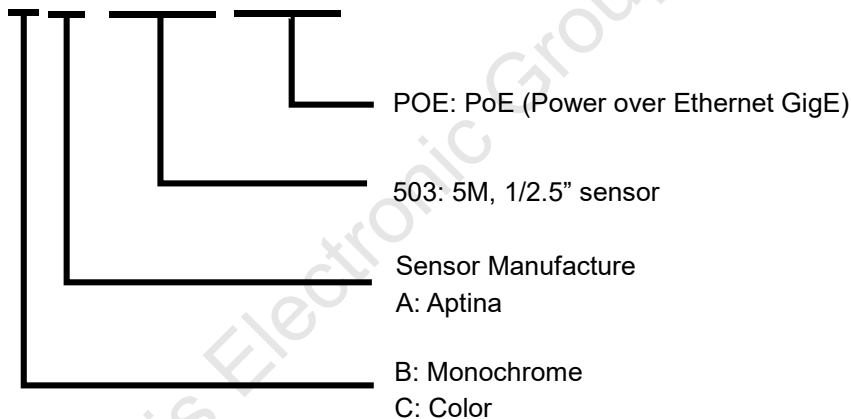

4 Specifications

4.1 Electronic Specifications

| Model Number | | STC-SBA503POE | STC-SCA503POE |
|--|-------------------------------|--|--|
| Image Sensor | | 1/2.5" 5M Progressive Monochrome CMOS (Aptina:MT9P031) | 1/2.5" 5M Progressive Color CMOS (Aptina:MT9P031) |
| Shutter Type | | Global Reset Release / Rolling Shutter | |
| Active Picture Elements | | 2,592 (H) x 1,944 (V) | |
| Cell Size | | 2.2 (H) x 2.2 (V) μ m | |
| Sync Method | | External trigger (Hardware / Software) / Free run | |
| Maximum Frame Rate (at Full scanning) | 8bits output | 14 fps | |
| | 10bits output | 11 fps | |
| | 10bits Packed output | 14 fps | |
| | 12bits output | 11 fps | |
| | 12bits Packed output | 14 fps | |
| ADC bit depth | | 10bits / 12bits | |
| Image Output Format | | Mono8 / Mono10 / Mono10Packed, / Mono12 / Mono12Packed | BayerRG8 / BayerRG10 / BayerRG10Packed / BayerRG12 / BayerRG12Packed |
| Noise Level | 8bits output | Less than 3 digits (Gain 0 dB) | |
| | 10bits / 10bits Packed output | Less than 13 digits (Gain 0 dB) | |
| | 12bits / 12bits Packed output | Less than 52 digits (Gain 0 dB) | |
| Minimum Scene Illumination | | 0.1 Lux at F1.2 (Gain Max) | 16 Lux at F1.2 (Gain Max) |
| Exposure Time | Free run | 32 μ seconds to 16.777 seconds (Default: 71,118.0 μseconds) | |
| | Edge Preset Trigger | | |
| | Pulse Width Trigger | 32 μ seconds to Non-limit seconds | |
| Gain | Analog | 0 to 7.51 dB (Default: 0 dB) | |
| | Digital (Sensor) | x1 to x6 (Default: x1) | |
| | Digital (FPGA) | x1 to x3 (Default: x1) | |
| Gamma | | Gamma 1.0 (Factory default) or unloadable gamma table (Default:1) | |
| ROI | | Horizontal: 32 to 2,592 pixels / Vertical: 32 to 1,944 lines (Default: 2,592 x 1,944) Adjustable steps for image size: 8 pixels in horizontal direction / 2 lines in vertical direction Adjustable steps for offset: 8 pixels in horizontal direction / 2 lines in vertical direction | |
| Multi ROIs | | N/A | |
| Binning | | H:1/2 / V:1/2, 1/4 / Off | |
| Decimation(Skipping) | | H 1/2, 1/3, 1/4, 1/5, 1/6, 1/7, Off / V 1/2, 1/3, 1/4, 1/5, 1/6, 1/7, Off | |
| Flip Image | | Horizontal / Vertical / Horizontal-Vertical / Off | N/A |
| Pixel Blemish Correction | | Up to 64 points (Default: ON) | |
| Auto Image Control | Auto Exposure | Support | Support |
| | Auto Gain (AGC) | Support | Support |
| | Auto White Balance | N/A | Support |
| Operational Mode | | Edge Preset Trigger / Pulse Width Trigger / Free run | |
| Communication | | UART communication through Ethernet port | |
| Interface | | IEEE802.3 (1000BASE-T) | |
| Protocol | | GigE Vision 1.2 GenICam 1.4 | |

Default: **Bold**

| Model Number | | STC-SBA503POE | STC-SCA503POE |
|--------------|-------------------|---|---------------|
| I/O | | One opt-isolated input and two open collector outputs (+3.3 V) | |
| Power | Input Voltage | +10.8 to +26.4 Vdc (IO Connector) or Power Over Ethernet (IEEE802.3af compliance) | |
| | Power Consumption | +12 Vdc: Less than 3.0 W / Power Over Ethernet: Less than 3.0 W | |

Precautions

(*1) The horizontal and vertical can be set individually for binning and decimation functions.
The combination of binning and decimation function is defined.

(*3) The binning and decimation function cannot use simultaneously.

Aegis Electronic Group, Inc.

4.2 Spectral Sensitivity Characteristics

4.2.1 STC-SBA503POE

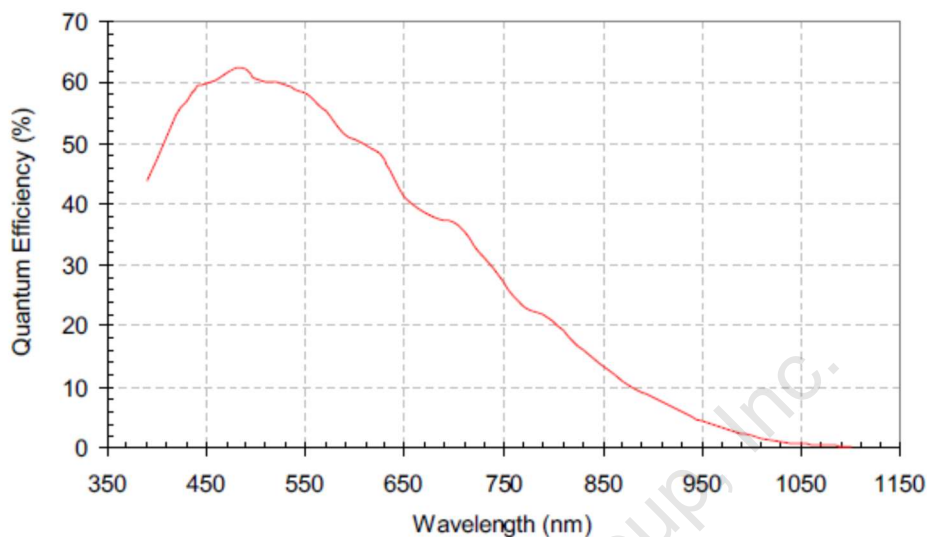

4.2.2 STC-SCA503POE

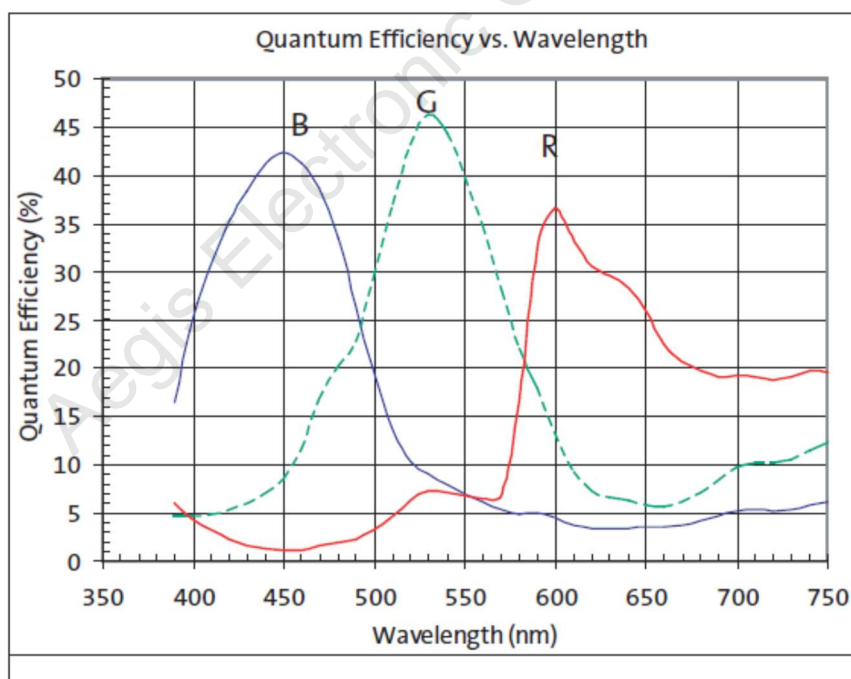

4.2.3 IR Cut Filter (STC-SCA503POE)

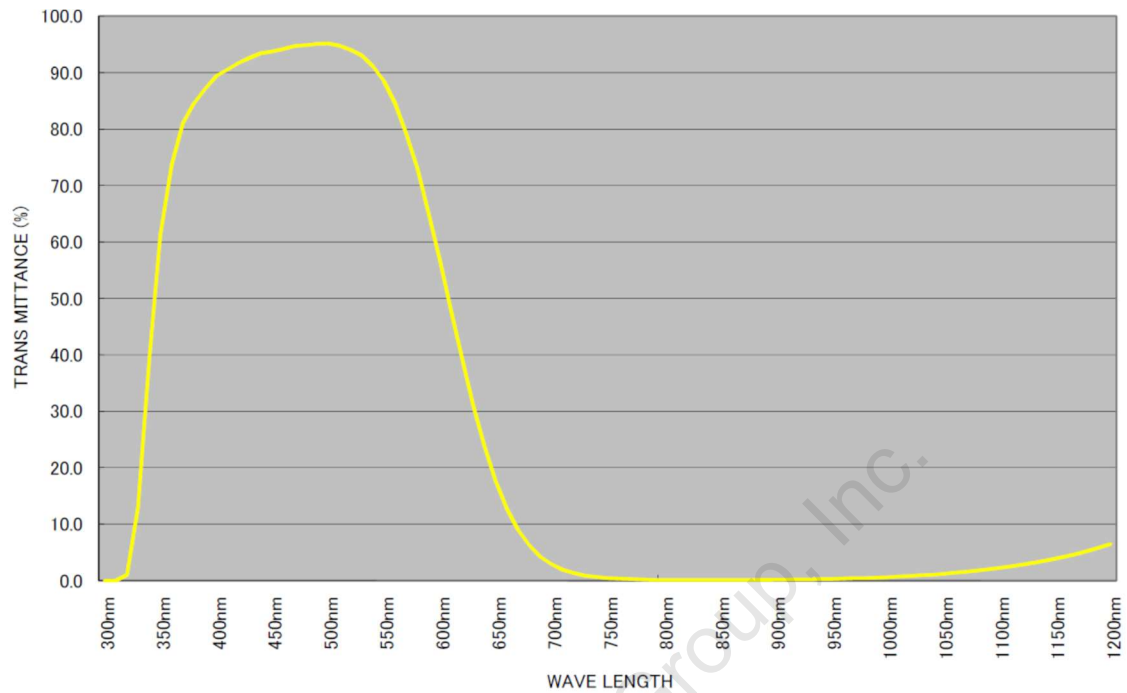

4.3 Mechanical Specifications

| Model Number | STC-SBA503POE | STC-SCA503POE |
|-------------------------|---|---------------|
| Dimensions | 35 (W) x 35 (H) x 53.5 (D) mm (*1) | |
| Optical Filter | No Optical Filter | IR Cut Filter |
| Optical Center Accuracy | Positional accuracy in Horizontal and Vertical directions: +/- 0.3 mm Rotational accuracy of Horizontal and Vertical: +/- 1.5 deg. | |
| Material | Aluminum (AC) | |
| Lens Mount | C mount | |
| Connectors | RJ45 connector Power- I/O connector: HR10A-7R-6PB (Hirose) or equivalent | |
| Camera Mount Screws | Two 1/4" Tripod screw holes: (One on each top and bottom plate) Twelve M4 screws holes: (Four on each top and bottom plate) | |
| Weight | Approximately 97 g | |

(*1) Excluding connectors

4.4 Environmental Specifications

| Model Number | | STC-SBA503POE | STC-SCA503POE |
|------------------------------------|--------------|--|---------------|
| Operational Temperature / Humidity | Minimum | Environmental Temperature: -5 deg. C, Environmental Humidity: 0 to 85 %RH (No condensation) | |
| | Maximum (*1) | Camera housing temperature (top plate) shall not exceed +65 deg. C (This corresponds to an environmental temperature of approximately +40 deg. C), Environmental Humidity: 0 to 85 %RH (No condensation) | |
| Storage Temperature / Humidity | | Environmental Temperature: -30 to +65 deg. C, Environmental Humidity: 0 to 85 %RH (No condensation) | |
| Vibration | | 20 Hz to 200 Hz to 20 Hz (5 min. / cycle), acceleration 10 G, XYZ 3 directions 30 min. each | |
| Shock | | Acceleration 38 G, half amplitude 6 mseconds, XYZ 3 directions 3 times each | |
| Standard Compliancy | | EMS: EN61000-6-2, EMI: EN55011 | |
| RoHS | | RoHS Compliance | |

(*1) When the camera using under the condition that exceeds +40 deg. C environmental temperature, please insure the camera installs with the appropriate heat dissipation to keep the housing temperature less than +65 deg. C. If camera has a mounted lens and a tripod with an aluminum plate, this could decrease the camera housing temperature for heat dissipation.

Taking these steps will maintain the heat rating of the electronic components of the camera.

Upper side of camera

Measuring point

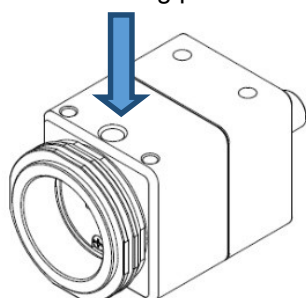

5 Connector Specifications

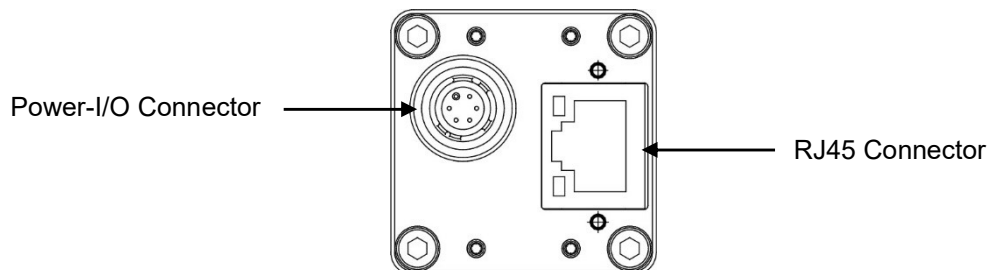

5.1 RJ45 Connector

This product is PoE compliant. Please supply power (+10.8 to +26.4 Vdc) through the power-I/O connector when using a non-PoE-compliant NIC.

Pin Assignment

| Pin No. | Signal Name |
|---------|-------------|
| 1 | TA+ |
| 2 | TA- |
| 3 | TB+ |
| 4 | TC+ |
| 5 | TC- |
| 6 | TB- |
| 7 | TD+ |
| 8 | TD- |

LED

| Green LED | Yellow LED | Status |
|-----------------|-----------------------|---------------------|
| Green Light ON | Yellow Light ON | Power ON(1GB NIC) |
| Green Light OFF | Yellow Light OFF | Power ON(100MB NIC) |
| Green Light ON | Yellow Light Blinking | 1Gb Transferring |
| Light OFF | Yellow Light Blinking | 100 Mb Transferring |

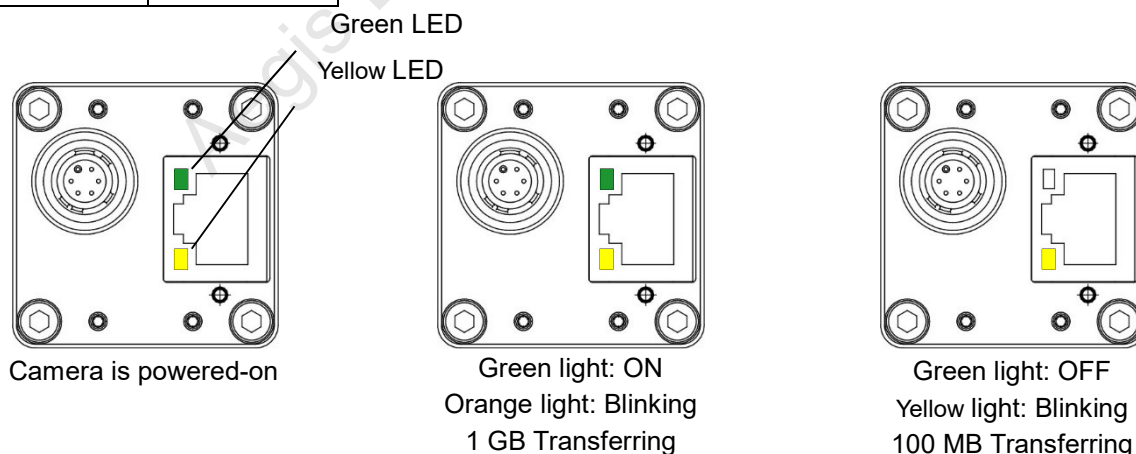

Please use a 1GB supported NIC, Network Switcher and LAN cable. Check that the NIC and Network Switcher being used is "1GB transferring".

5.2 Power and Control Signal Connector

- HR10A-7R-6PB (Hirose) or equivalent
- This connector is for the power supply (12 Vdc) and input /output signals.
- Use HR10A-7P-6S (Hirose) or equivalent for the cable side.

Pin assignment

| Pin No. | Signal Name | IN / OUT | Voltage |
|---------|------------------------------|----------|--|
| 1 | GND | IN | 0 V |
| 2 | I/O-1 | OUT | +3.3 V Open Collector |
| 3 | I/O-2 | OUT | +3.3 V Open Collector |
| 4 | TRG_In- (Opt. Isolated -) | IN | Low: Smaller than +1.0 V High: +3.0 to +26.4 V |
| 5 | TRG_In+ (Opt. Isolated +) | IN | * potential difference between TRG_In- and TRG_In+ |
| 6 | POWER IN | IN | +10.8 to +26.4 Vdc |

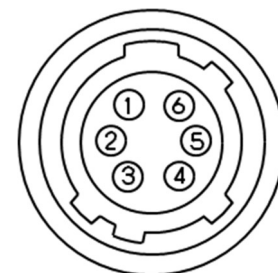

Configuration of I/O-1(Pin No.2) and I/O-2(Pin No.3)

Output pin can be assigned through register setting or GenICam Command.

| GenICam command |
|---|
| I/O-1 (Pin No.2) / I/O-2 (Pin No.3) |
| 1) FrameTriggerWait (initial setting for I/O-1) |
| 2) UserOutput |
| 3) ExposureActive (initial setting for I/O-2) |
| 4) TriggerAuxiliary |
| 5) TriggerInternal |
| 6) SensorReadOut |
| 7) StrobeSignal |

1) FrameTriggerWait

The user can check the camera condition (camera exposure and image output processing by the trigger signal with this FrameTriggerWait signal).

This signal is LOW for the period from the trigger input signal to the image output.

2) UserOutput

The status of the UserOutput signal can change with the "UserOutputValue".

3) ExposureActive

The user can check the exposure time with the ExposureActive signal.

4) TriggerAuxiliary

The TriggerAuxiliary signal is the input trigger signal.

5) TriggerInternal

The TriggerInternal signal is the input trigger signal with the trigger delay time.

6) SensorReadOut

The SensorReadOut signal is the FVAL signal, which is the image output period of the time.

7) StrobeSignal

The StrobeSignal signal is the strobe control signal.

Aegis Electronic Group, Inc.

5.2.1 Equivalent Circuit for the Input Pin of the I/O Connector

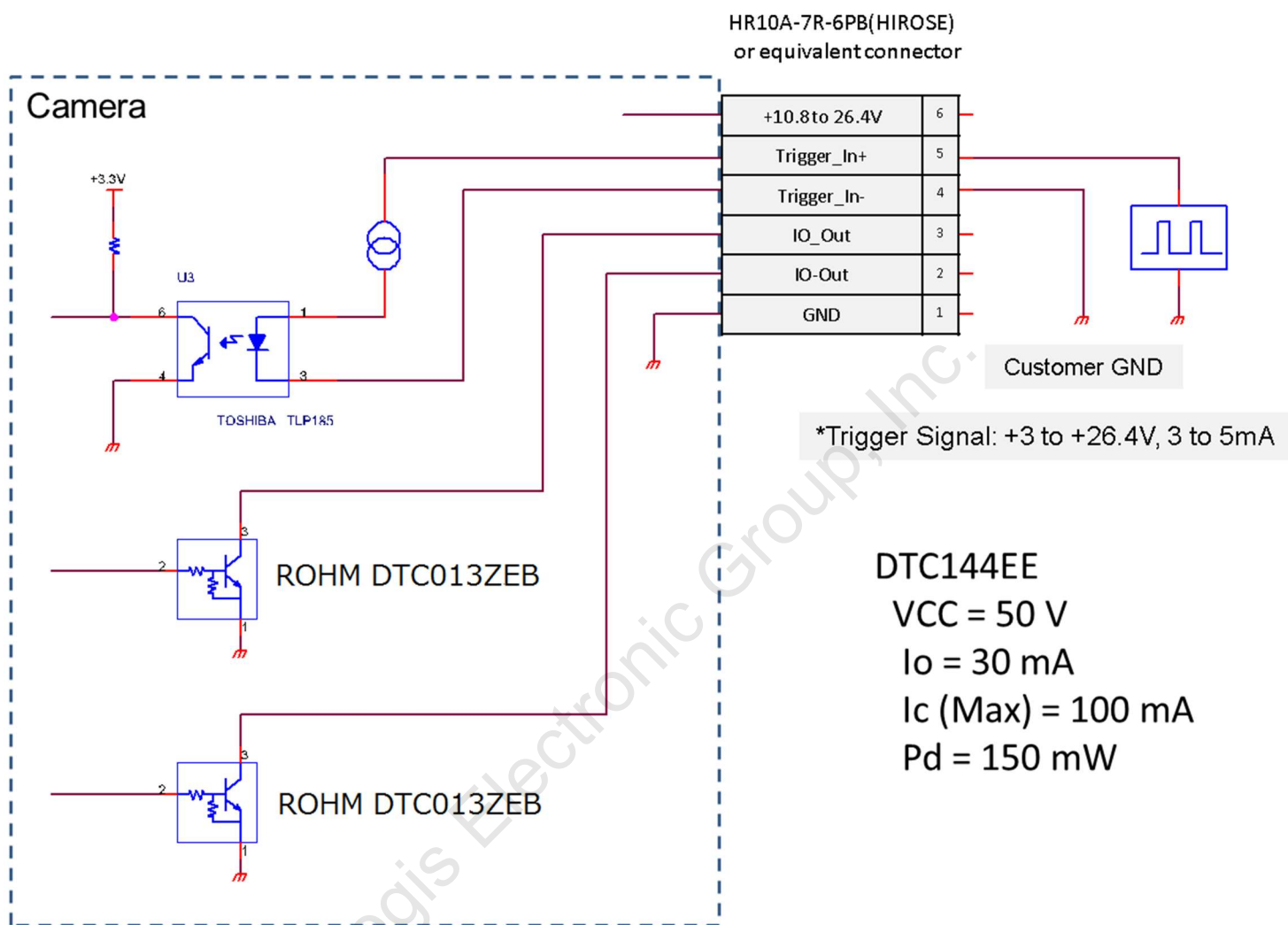

5.2.2 Typical Input Circuit

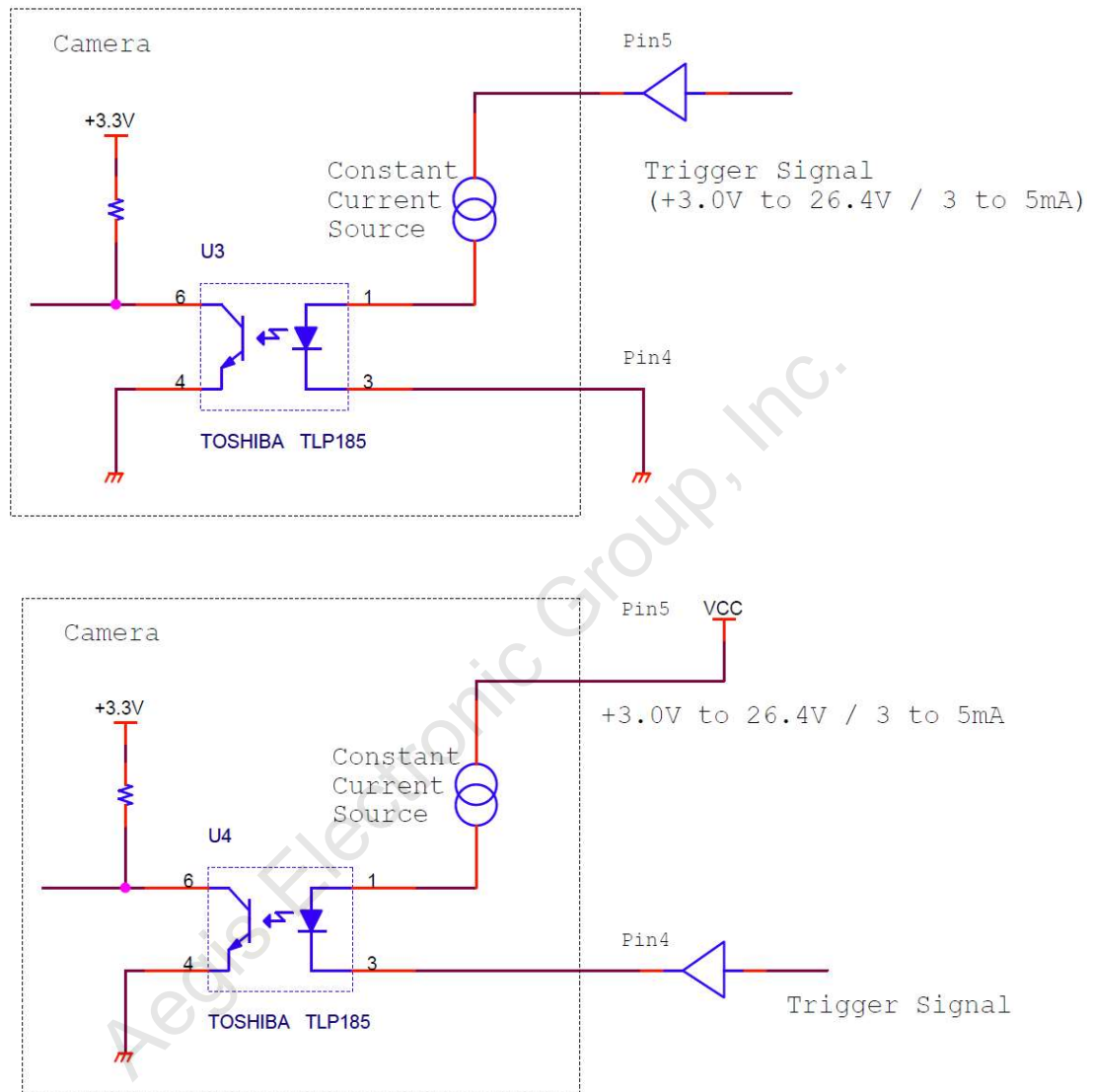

5.2.3 Typical Output Circuit

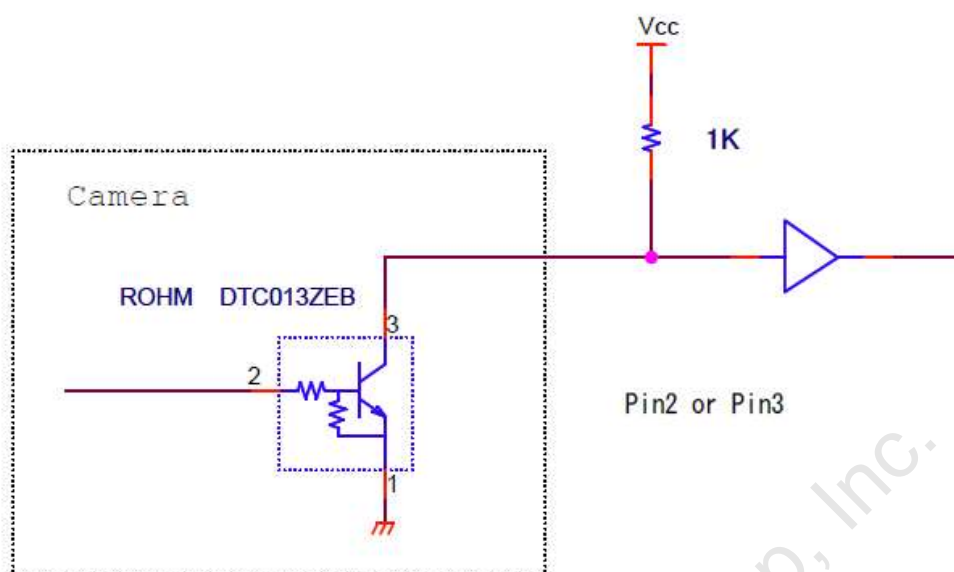

Note:
Value of Vcc and
Pull up register can be
set within the spec of
transistor.

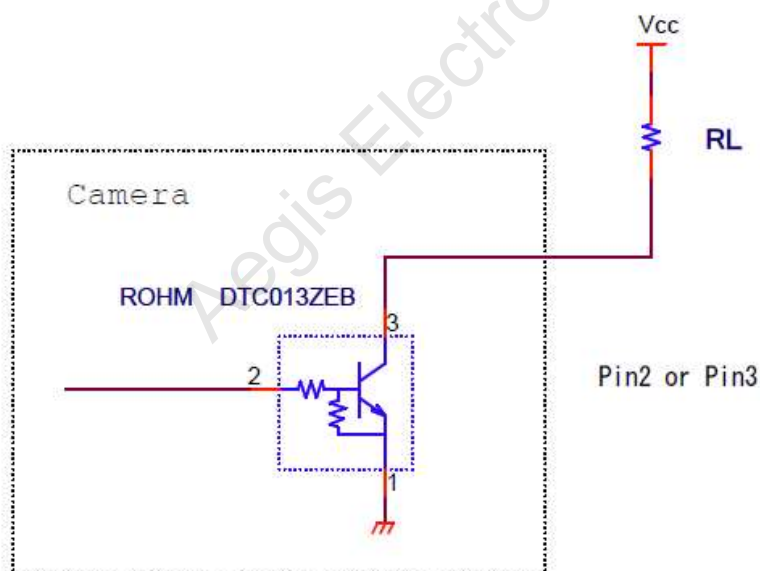

5.2.4 Input and Output Signal Timing (Hardware Trigger)
 Case of "External Hardware Trigger", "Positive Edge Trigger", "Edge Preset Exposure",

Camera internal processing

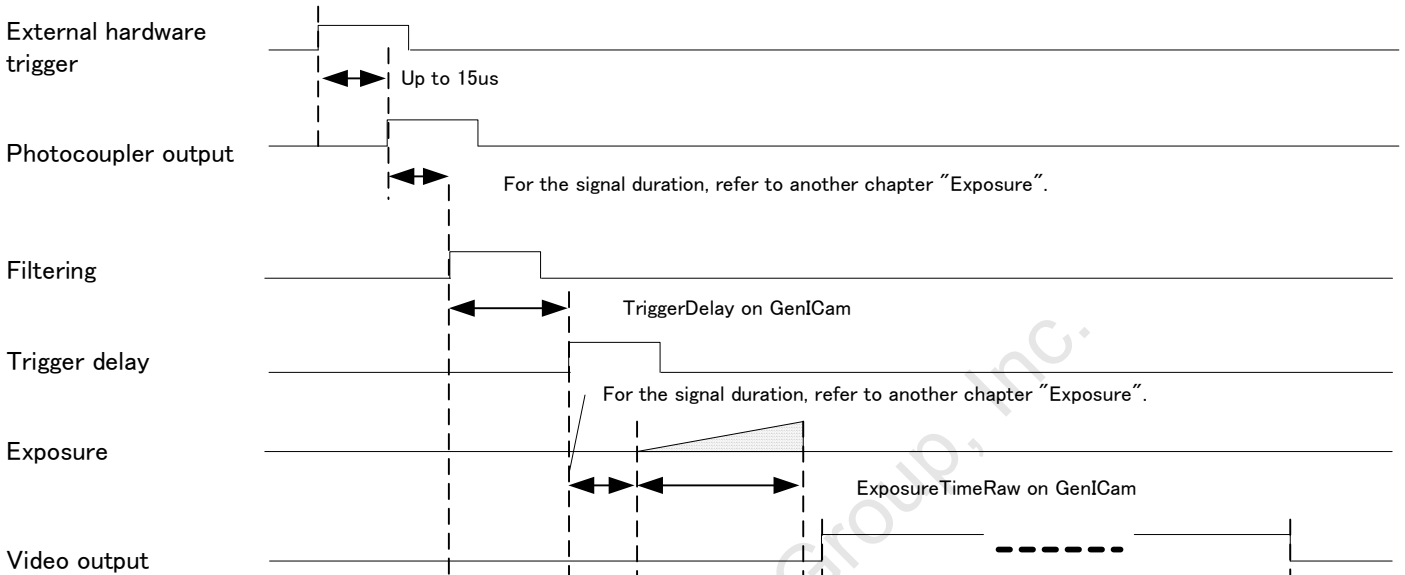

Output Signal

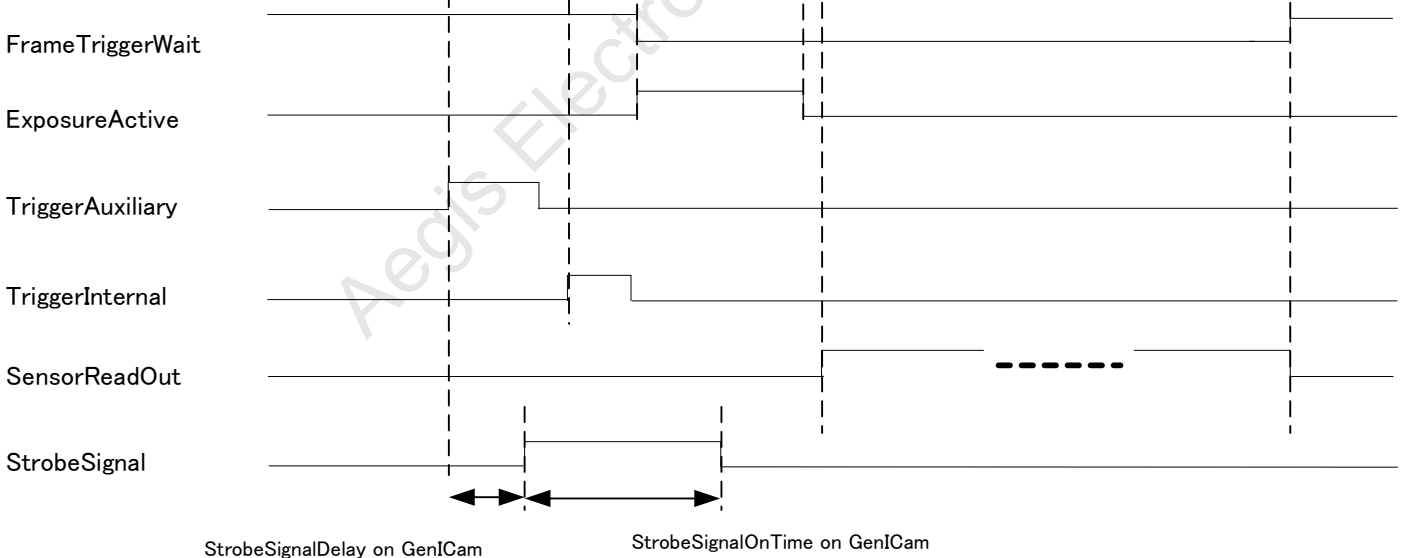

5.2.5 Input and Output Signal Timing (Software Trigger)
 Case of "Software Trigger", "Positive Edge Trigger", "Edge Preset Exposure",

Camera internal processing

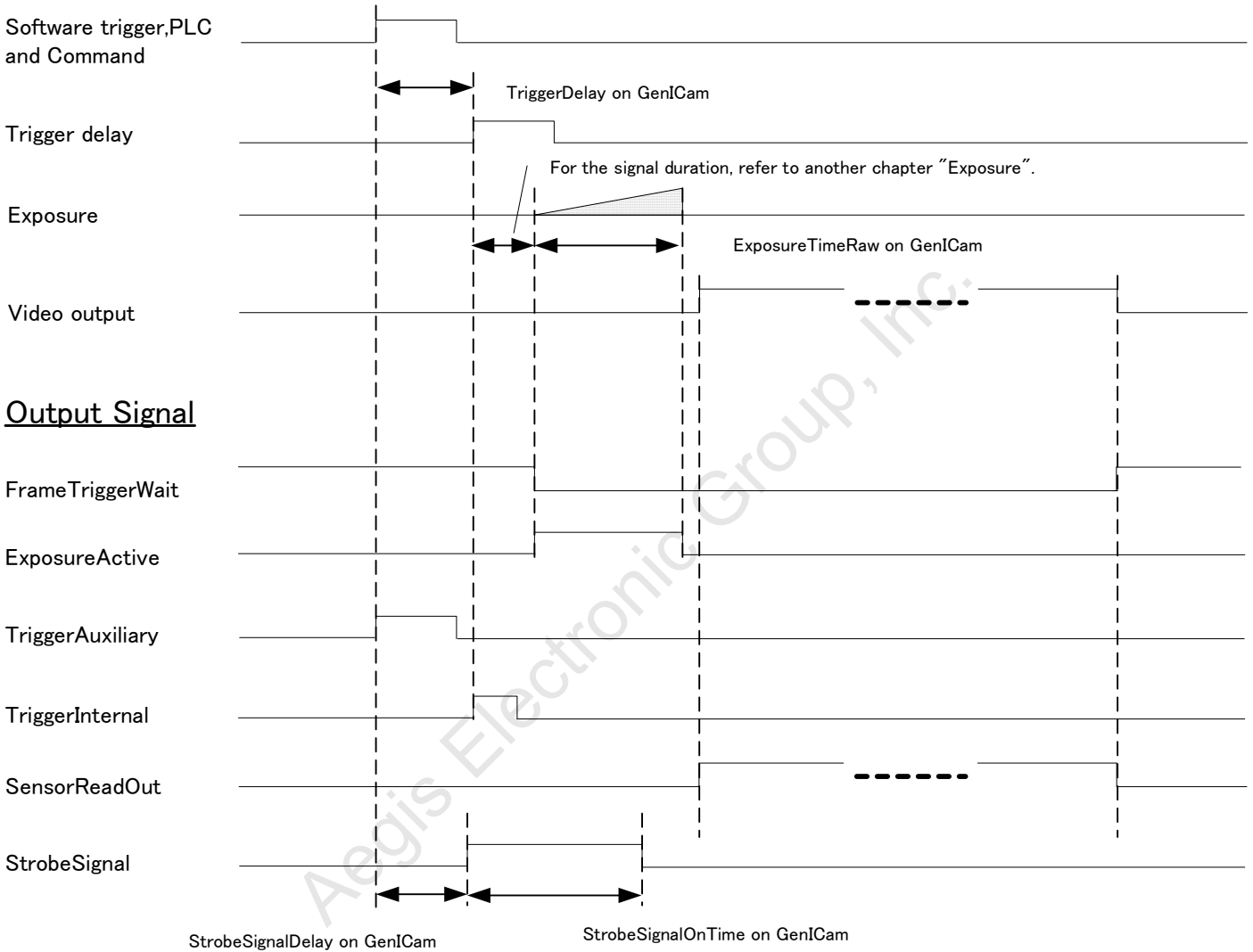

6 Dimensions

6.1 STC-SBA503POE

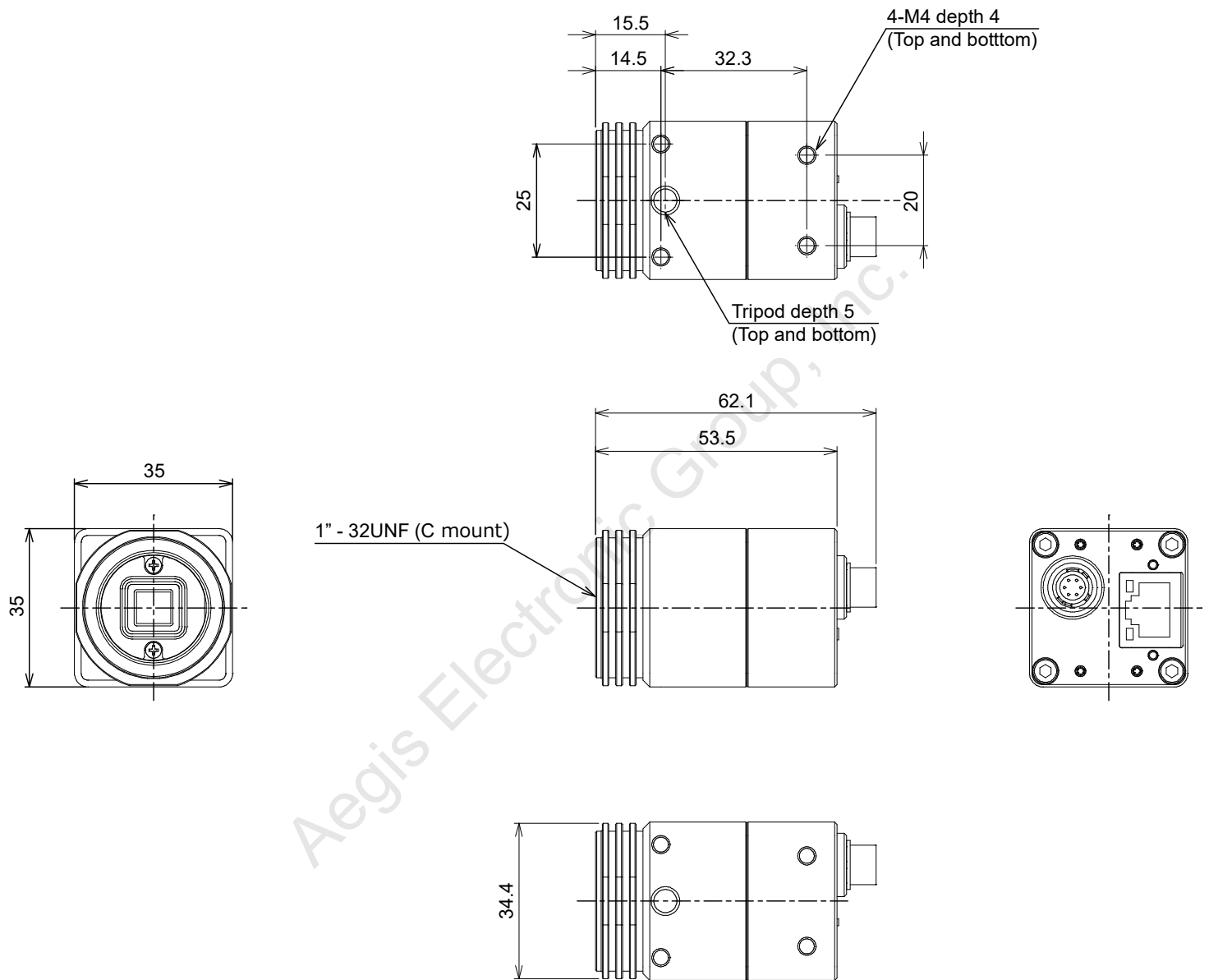

Unit: mm

6.2 STC-SCA503POE

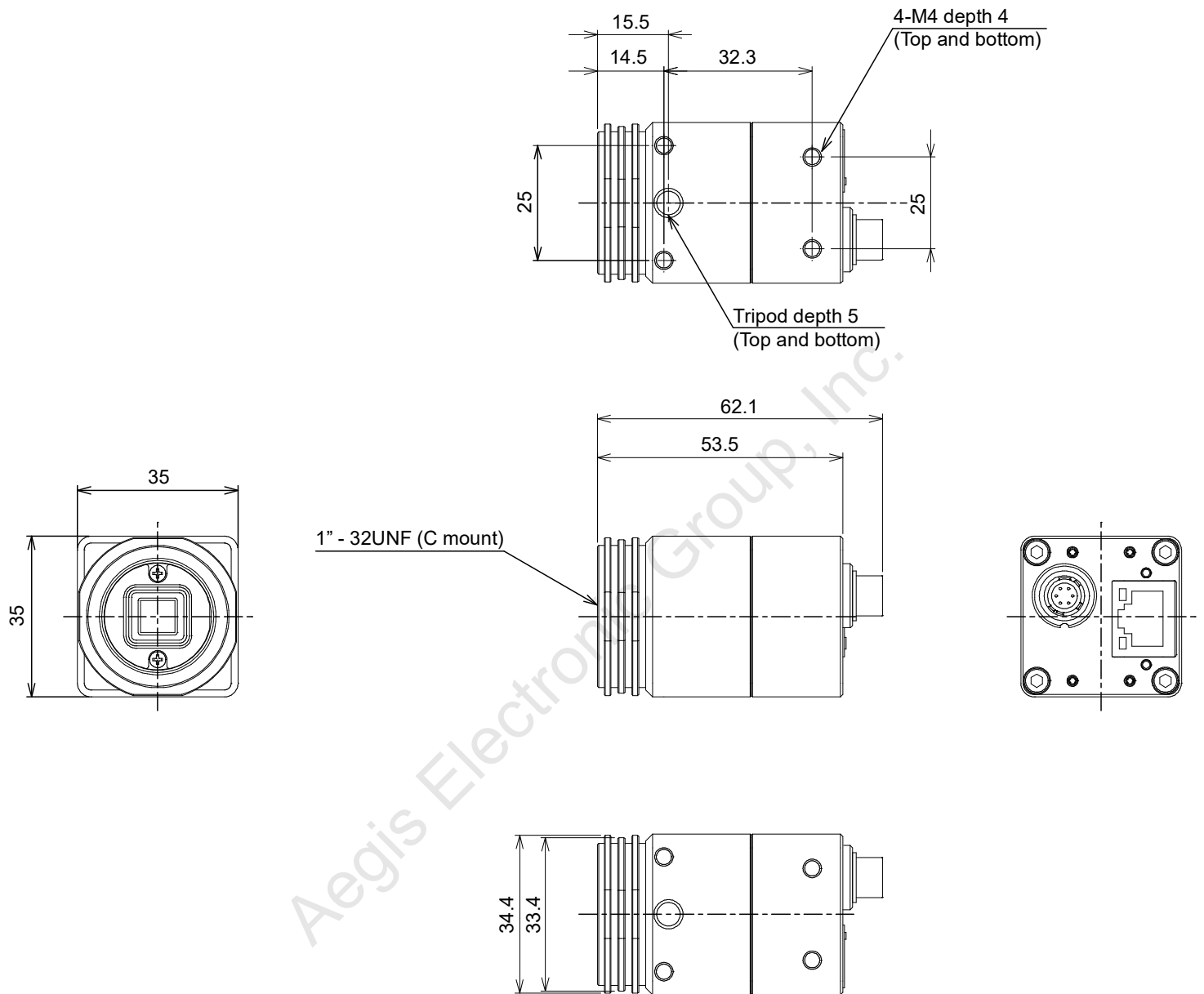

Unit: mm

7 Sensor information

7.1 Pixel Transferring Image

STC- SBA503POE (Monochrome)

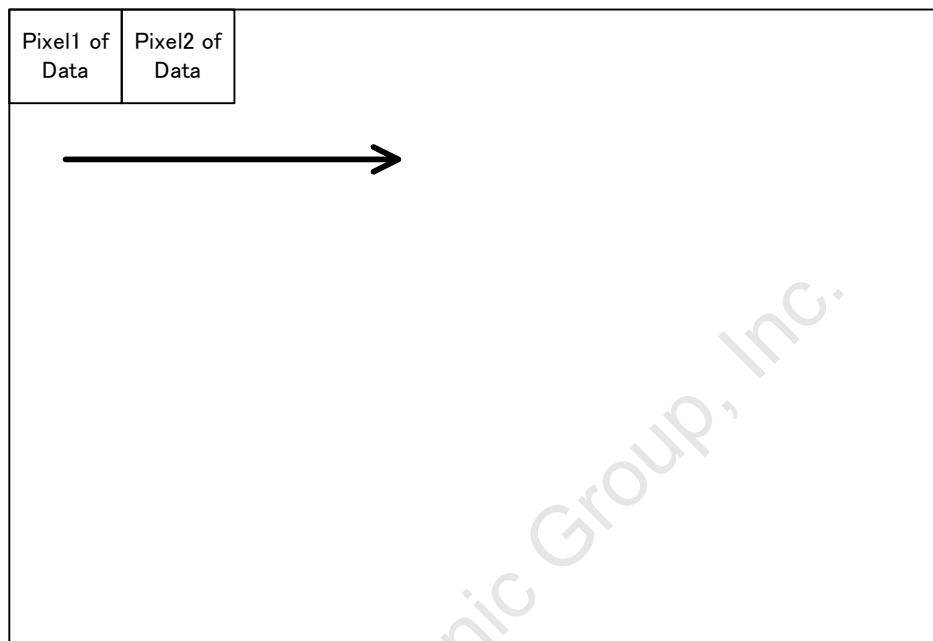

Pixel (n) of Data: nth pixel being transferred

STC- SCA503POE (Color)

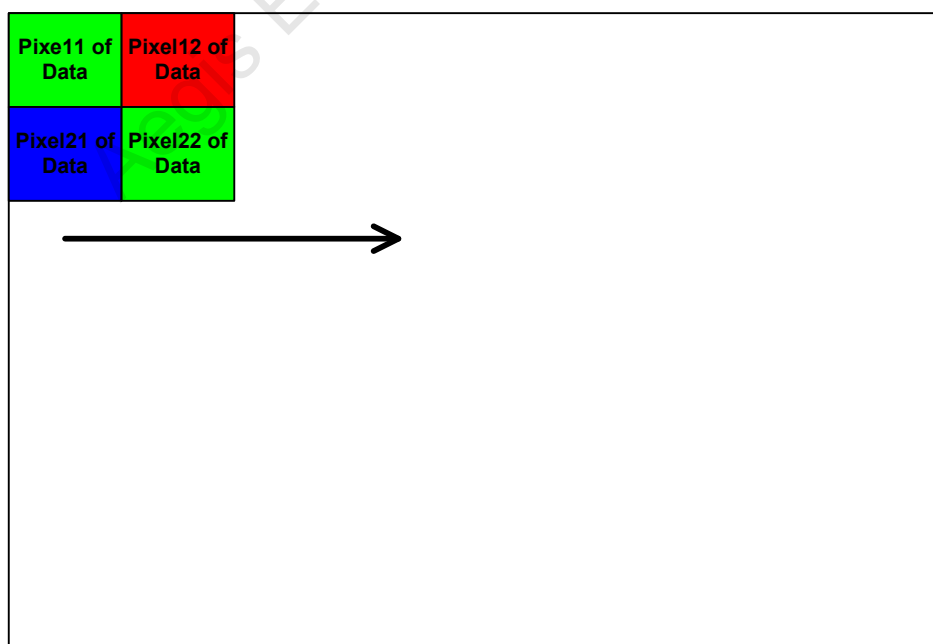

Pixel (m, n) of Data: nth pixel of the mth line being transferred

8 Camera Operational Modes

8.1 Normal Mode (TriggerMode = Off)

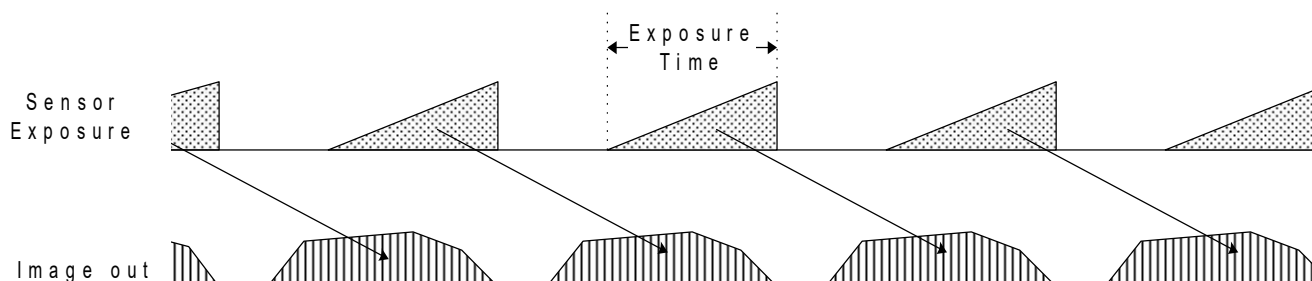

8.2 Pulse width trigger mode (ExposureMode = TriggerWidth)

In this trigger mode with positive polarity, the camera exposure starts at the rising edge of the trigger pulse and stops at the falling edge of the trigger pulse. Therefore, if positive polarity exposure is selected, the exposure periods are the high states of the trigger pulse.

*Note: When set TriggerMode = Off under TriggerMode = On, ExposureMode = TriggerWidth, please set ExposureMode = Timed at first, and after that set TriggerMode = Off.

8.2.1 Timing

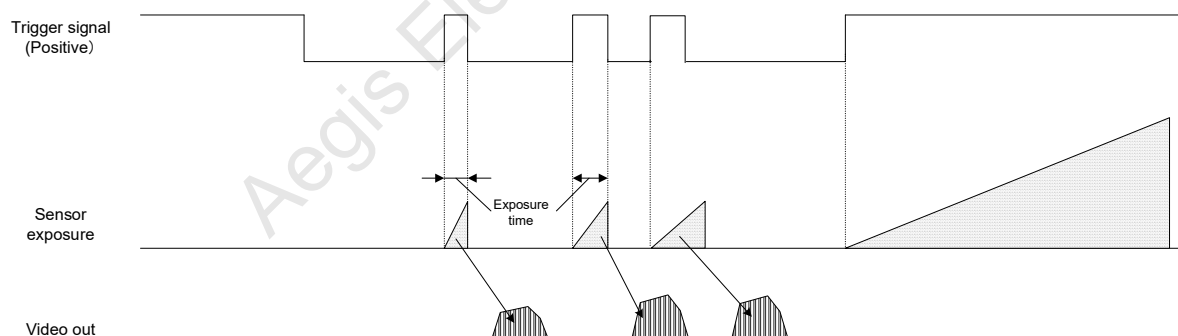

Note 1: The exposure time is set by active pulse duration of trigger signal.

8.2.2 Exposure Timing with the Positive Polarity Trigger Signal

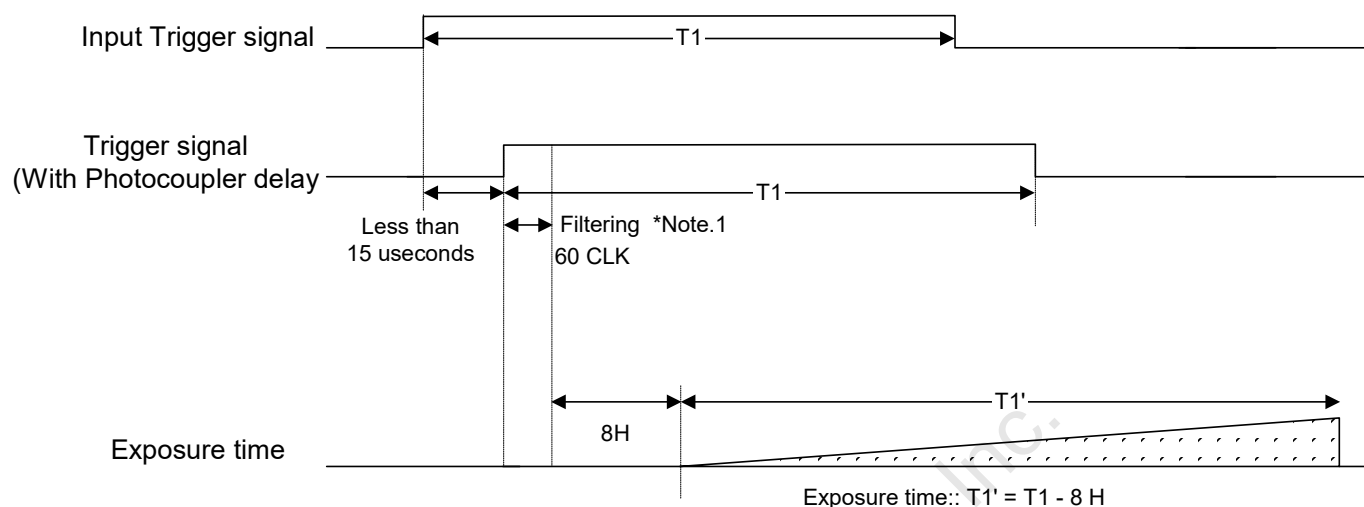

Note 1: The trigger signal will be removed by the filtering if the pulse width of the input trigger signal is less than 60 CLK. Please input a trigger signal with more than 61 CLK pulse width.

Note 2: The exposure will start 8H after the rising edge of the trigger signal.

8.2.3 Exposure Timing with the Negative Polarity Trigger Signal

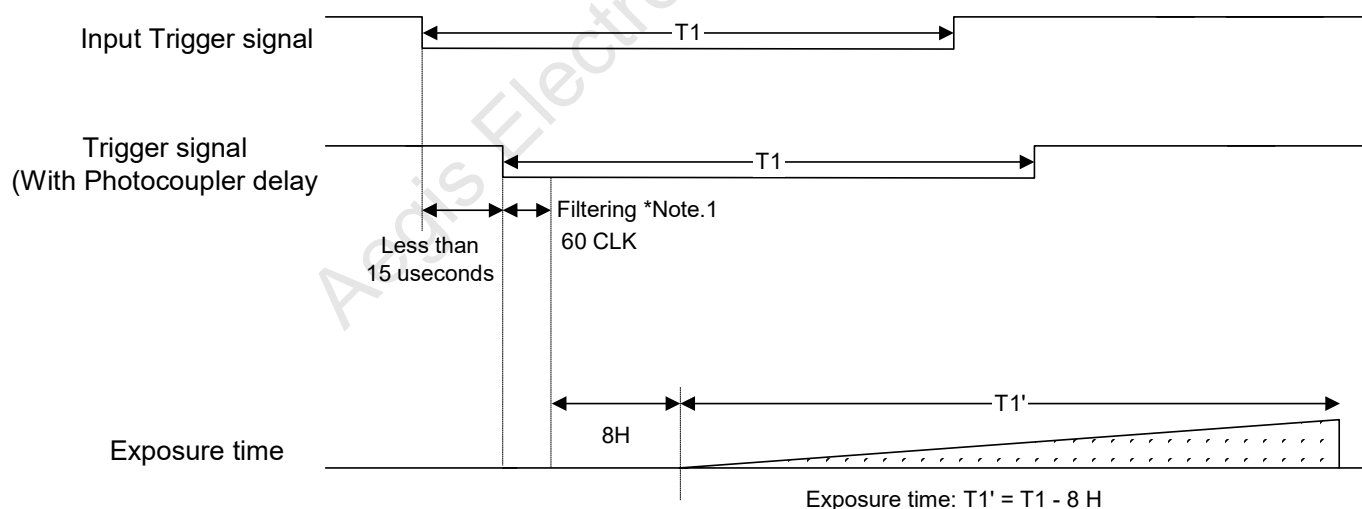

Note 1: The trigger signal will be removed by the filtering if the pulse width of the input trigger signal is less than 60 CLK. Please input a trigger signal with more than 61 CLK pulse width.

Note 2: The exposure will start 8H after the rising edge of the trigger signal.

8.3 Edge Preset Trigger Mode (ExposureMode = Timed)

In this “edge preset trigger mode”, the camera exposure starts at the rising edge of the trigger signal like the “pulse width trigger mode” in the previous sections. However, in this mode, the exposure duration time is based on the preset value stored by the camera setting communication.

8.3.1 Timing

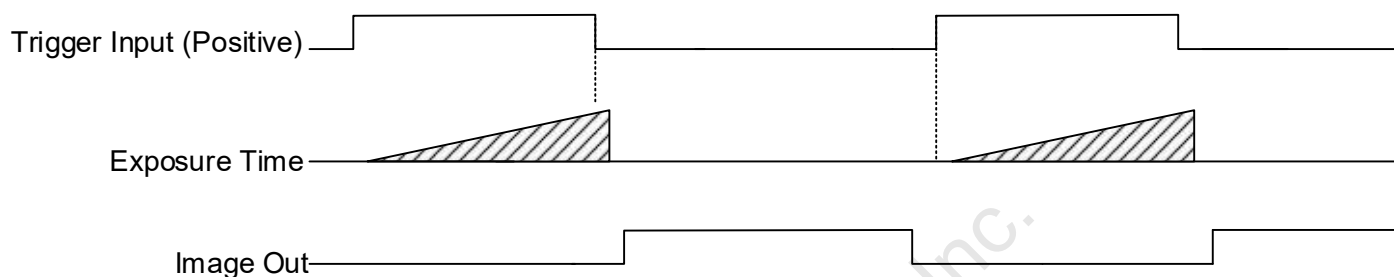

Note 1: The exposure time is set by the preset electronic shutter speed.

8.3.2 Exposure Timing with the Positive Polarity Trigger Signal

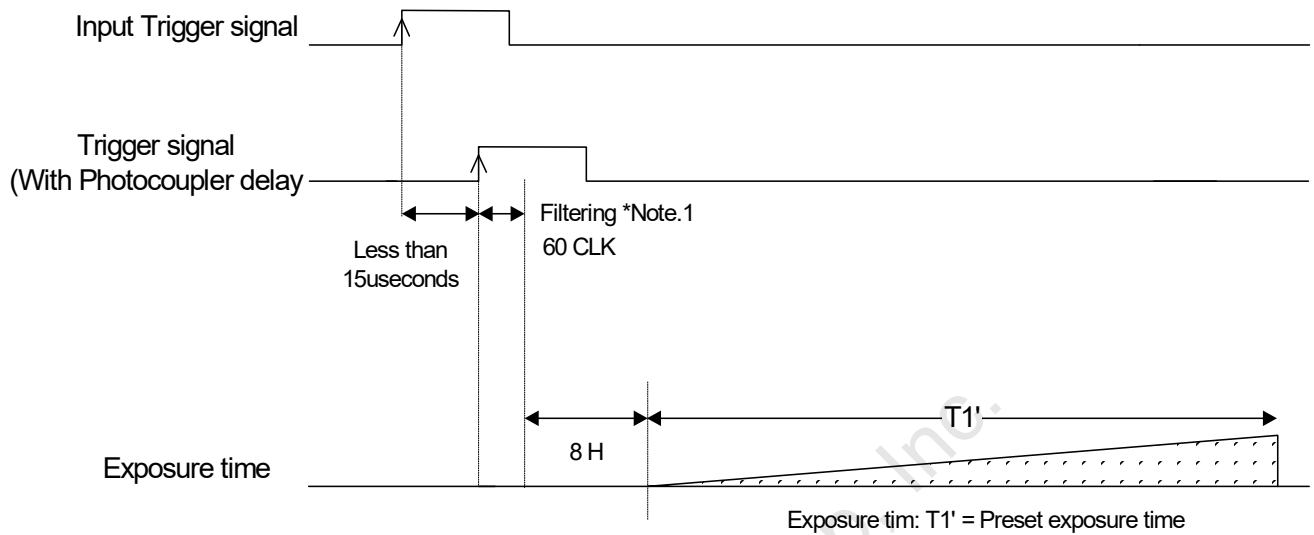

Note 1: The trigger signal will be removed by the filtering if the pulse width of the input trigger signal is less than 60 CLK.
Please input a trigger signal with more than 61 CLK pulse width.

Note 2: The exposure will start 8H after the rising edge of the trigger signal.

8.3.3 Exposure Timing with the Negative Polarity Trigger signal

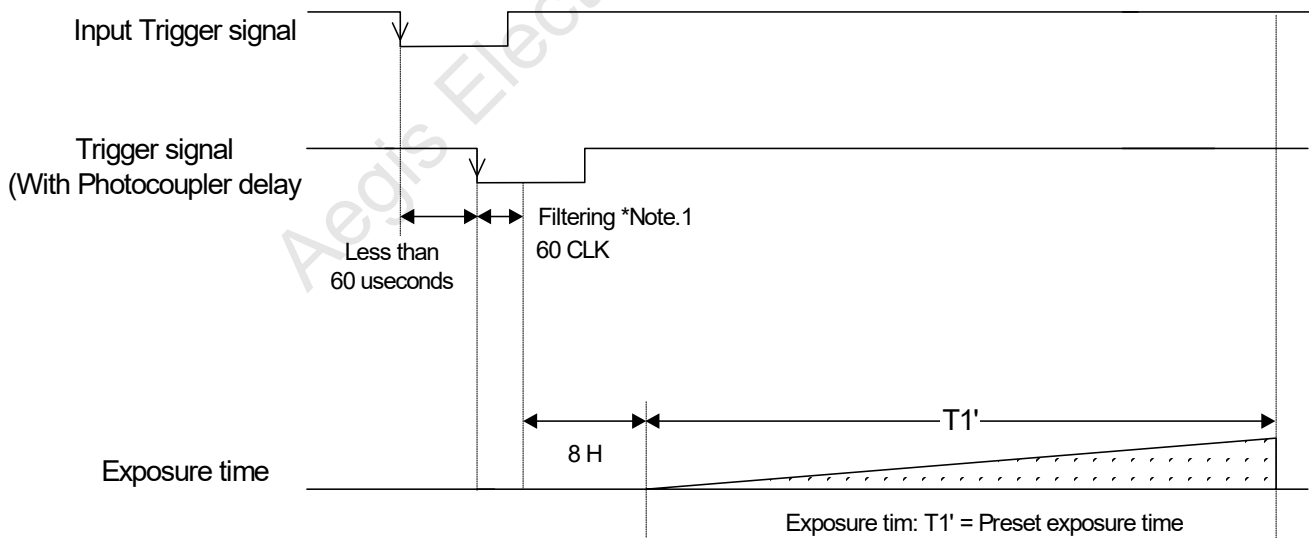

Note 1: The trigger signal will be removed by the filtering if the pulse width of the input trigger signal is less than 60 CLK.
Please input a trigger signal with more than 61 CLK pulse width.

Note 2: The exposure will start 8H after the rising edge of the trigger signal.

8.4 Edge Preset Trigger Mode (Trigger Input While the Image Is Out)

In this trigger mode, the camera exposure starts at the rising edge of the trigger pulse.

If trigger signal input is required while the image is out, then it is necessary to disable the trigger signal mask with the communication.

To avoid generating additional noise on the image, it is necessary to set the “H reset” at the exposure start mode.

8.4.1 Timing

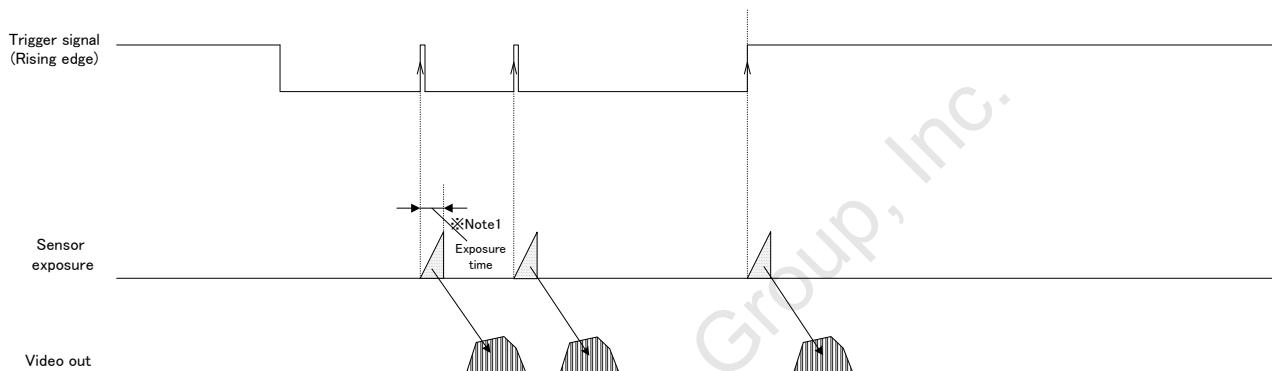

Note 1: The exposure time is set by the preset electronic shutter speed.

8.5 CMOS Rest Type

With this camera, you can select the sensor exposure type as either "Electronic Rolling Shutter (ERS)" or "Global Reset Release (GRR)". When GRR is used under low light, the exposure at the bottom portion of image is longer than the exposure at the upper portion, so it becomes brighter.

ERS(for Edge Preset)

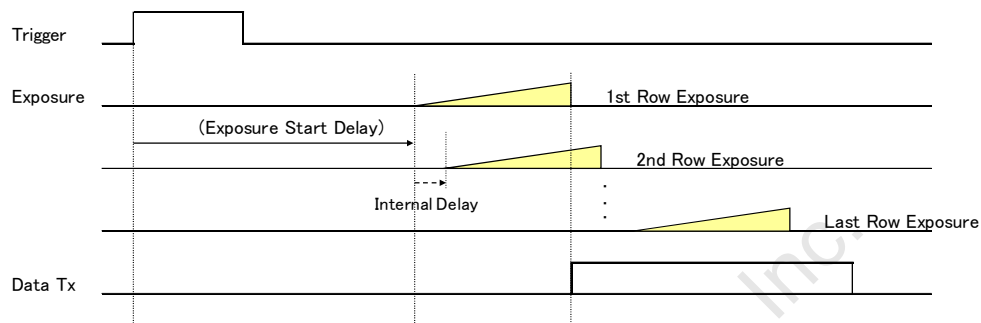

GRR(for EdgePreset) Note:This function works on Trigger-mode

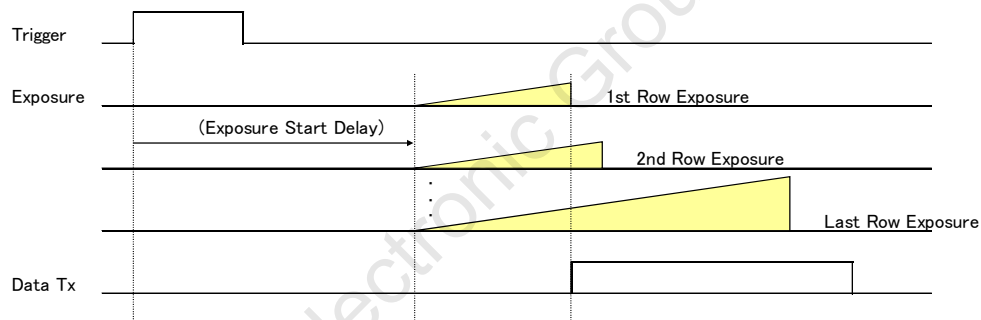

*Note1: When changing this CMOS reset type, please set the free-run mode (TriggerMode = Off) at first. If not, image may not come up.

9 Camera Functions

9.1 ROI (Region of Interest)

The specified area of the image can output from the camera with ROI function.

The frame rate is increased when the height is reduced.

The frame rate does not increase when the width is reduced.

9.1.1 ROI (1 region)

GenICam paramters

| | | |
|---------|--------------|--|
| Width | Integer type | Width of the output image (pixels) (Width + OffsetX) should not exceeded maximum width. |
| Height | Integer type | Height of the output image (lines) (Height + OffsetY) should not exceeded maximum height. |
| OffsetX | Integer type | Horizontal (pixel) offset Default: 0, Adjustable steps: 8 pixels |
| OffsetY | Integer type | Vertical offset for the output image (lines). Default: 0, Adjustable steps: 2 liens |

The ROI area settings are below:

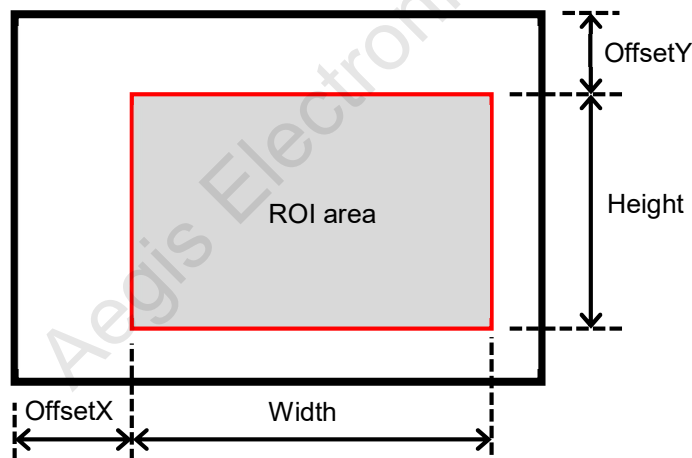

Width / Height setting range

| | | STC-SBA503POE STC-SCA503POE |
|--------|------------------|--------------------------------|
| Width | Range | 32 to 2,592 pixels |
| | Default | 2,592 pixels |
| | Adjustment steps | 8 pixels |
| Height | Range | 32 to 1,944 lines |
| | Default | 1,944 lines |
| | Adjustment steps | 2 lines |

Aegis Electronic Group, Inc.

9.2 Pixel Format

The image format from camera can be set on the Pixel Format.

GenICam Parameters

| | | |
|-------------|-------------------|--------------|
| PixelFormat | IEnumeration Type | Pixel Format |
|-------------|-------------------|--------------|

The following chart shows the available Pixel Formats on the camera:

| Output Bit | Pixel Format | |
|---------------|-------------------|-----------------|
| | Monochrome Camera | Color Camera |
| 8bits | Mono8 | BayerRG8 |
| 10bits | Mono10 | BayerRG10 |
| 10bits Packed | Mono10Packed | BayerRG10Packed |
| 12bits | Mono12 | BayerRG12 |
| 12bits Packed | Mono12Packed | BayerRG12Packed |
| RGB8 Packed | N/A | RGB8Packed |

Each format specified on GenICam PFNC (Pixel Format Naming Convention).

9.3 Binning

Binning OFF: BinningVertical = 1, BinningHorizontal = 1

A full resolution (2,592 x 1,944) images are output. The default frame rate is 14 fps

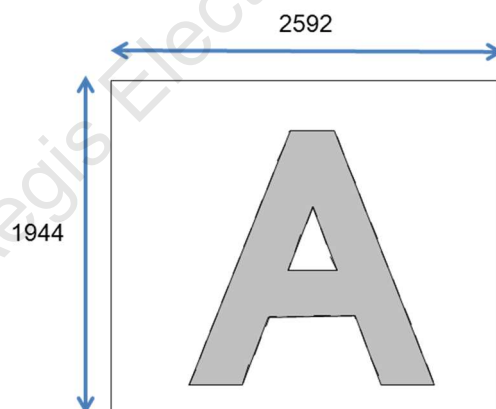

Binning Vertical 1/2: BinningVertical = 2, BinningHorizontal = 1

The width is full resolution, and approximately 1/2 of the height of the "Normal" image is output (2,592 x 972).

The image becomes the center portion of the "Binning" image. The Binning's frame rate is about 23 fps

*Note: Sensitivity may not increase on Vertical.

2592

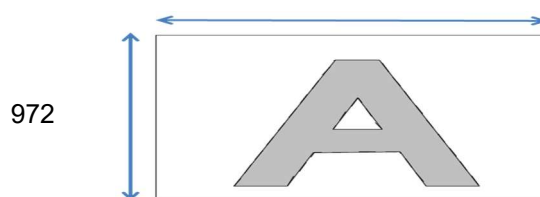

Binning Vertical 1/4: BinningVertical = 4, BinningHorizontal = 1

The width is full resolution, and approximately 1/4 of the height of the "Normal" image is output (2,592 x 486).

The image becomes the center portion of the "Binning" image. The Binning's frame rate is about 35 fps

*Note: Sensitivity may not increase on Vertical.

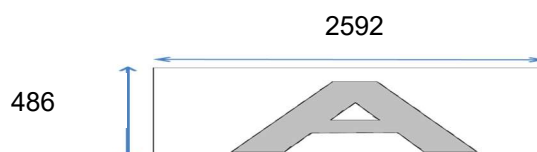

Horizontal Binnig

Added the beside pixel value are outputted on horizontal direction.

*Note:Sensitivity may increase on Horizontal.

| Resolution | fps | Setting |
|---------------|------------|--|
| 1,296 x 1,944 | Approx. 23 | BinningVertical = 1, BinningHorizontal = 2 |

9.4 Decimation (Skipping)

Vertical Decimation (Skipping)

Decimated vertical line images are output.

| Resolution | fps | Setting |
|-------------|------------|------------------------|
| 2,592 x 972 | Approx. 28 | DecimationVertical = 2 |
| 2,592 x 648 | Approx. 42 | DecimationVertical = 3 |
| 2,592 x 486 | Approx. 55 | DecimationVertical = 4 |
| 2,592 x 388 | Approx. 69 | DecimationVertical = 5 |
| 2,592 x 324 | Approx. 82 | DecimationVertical = 6 |
| 2,592 x 276 | Approx. 96 | DecimationVertical = 7 |

Horizontal Decimation (Skipping)

Decimated horizontal pixels are output.

| Resolution | fps | Setting |
|---------------|------------|--------------------------|
| 1,296 x 1,944 | Approx. 22 | DecimationHorizontal = 2 |
| 864 x 1,944 | Approx. 28 | DecimationHorizontal = 3 |
| 648 x 1,944 | Approx. 32 | DecimationHorizontal = 4 |
| 512 x 1,944 | Approx. 35 | DecimationHorizontal = 5 |
| 432 x 1,944 | Approx. 37 | DecimationHorizontal = 6 |
| 368 x 1,944 | Approx. 39 | DecimationHorizontal = 7 |

*Note1: When Horizontal/Vertical Binning are selected, capable Decimation (Skipping) numbers exist.

e.g.)

BinningHorizontal = 2 => DecimationHorizontal = 2 #1,3,4,5,6,7 cannot be selected
 BinningVertical = 2 => DecimationVertical = 2 #1,3,4,5,6,7 cannot be selected

9.5 Image Flip

Flip the image through ReverseX and ReverseY.

GenICam Parameters

| | | |
|----------|---------------|---|
| ReverseX | IBoolean Type | Switch ON / OFF at Horizontal False: Horizontal Flip Off, True: Horizontal Flip On. Default: False |
| ReverseY | IBoolean Type | Switch ON / OFF at Vertical False: Vertical Flip Off, True: Vertical Flip On. Default: False |

Reverse X(Off), Y(Off)

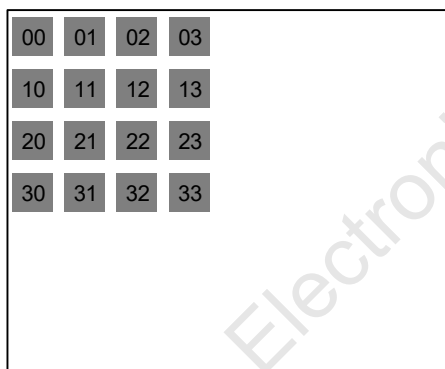

Reverse X(Off), Y(On)

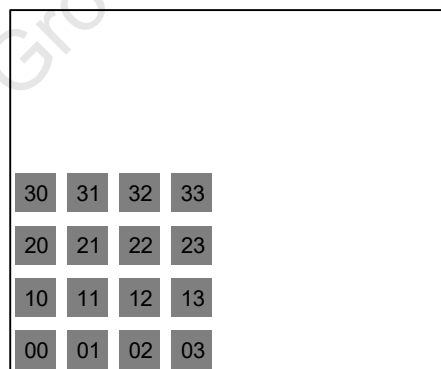

Reverse X(On), Y(Off)

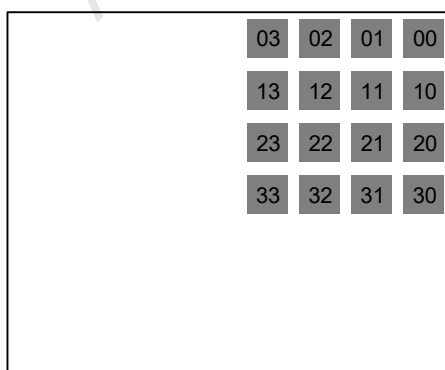

Reverse X(On), Y(On)

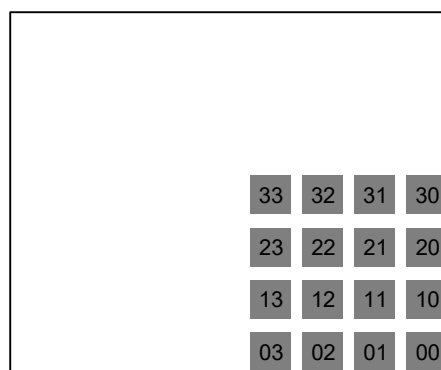

Reverse X(Off), Y(Off)

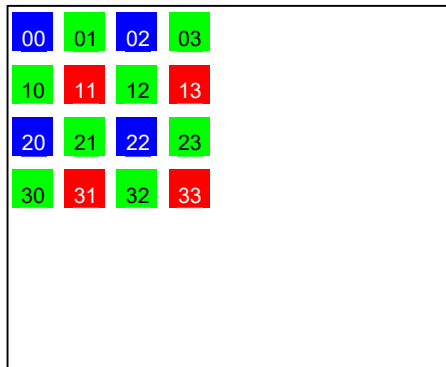

Reverse X(Off), Y(On)

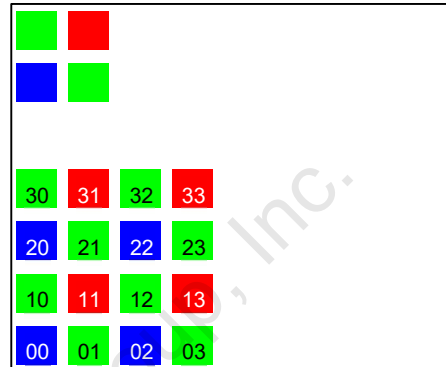

Reverse X(On), Y(Off)

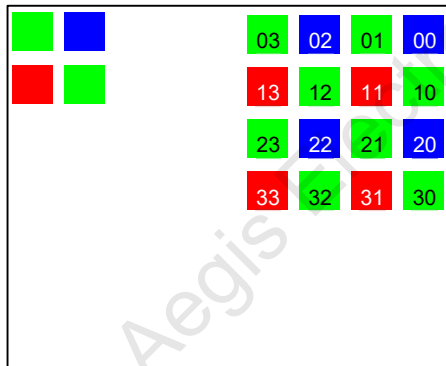

Reverse X(On), Y(On)

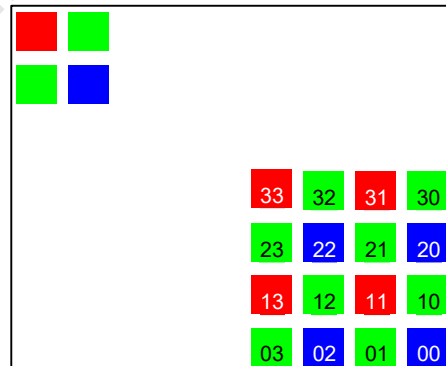

9.6 Gain

The analog gain and the digital gain are available for the gain control.

9.6.1 Analog gain

This parameter sets the analog gain.

GenICam parameter

| | | |
|------|------------|--|
| Gain | Float type | Analog gain. Range: 0 to 40, Default: 0 |
|------|------------|--|

Analog gain formula

$$\text{Gain (dB)} = \text{Gain} / 10$$

9.6.2 Digital gain

This parameter sets the digital gain.

GenICam parameter

| | | |
|-------------|--------------|--|
| DigitalGain | Integer type | Digital gain. Range: 0 to 255, Default: 0 |
|-------------|--------------|--|

Digital gain formula

$$\text{Gain (xtimes)} = 1 + (\text{DigitalGain} / 128)$$

9.7 Black level

This parameter sets the black level (the clamp level for the black signal).

The bottom of the signal is clamped at this setting level. The signal does not become below this level.

GenICam parameter

| | | |
|------------|------------|---|
| BlackLevel | Float type | Black level. Range: 0 to 20, Default: 31 |
|------------|------------|---|

Black level formula

$$\text{At 12bits output: Black level (grayscale)} = \text{BlackLevel} * 4$$

$$\text{At 10bits output: Black level (grayscale)} = \text{BlackLevel}$$

$$\text{At 8bits output: Black level (grayscale)} = \text{BlackLevel} / 4$$

9.8 ALC (Auto Light Control)

ALC function has two control methods, which is AGC (Auto Gain Control) and the auto shutter. The AGC and the auto shutter sets up individually.

The camera parameters are adjusted to the brightness of the image is maintained with the target brightness automatically with the ALC function.

GenICam parameters (for AGC and auto shutter)

| | | |
|--|--------------|---|
| TargetBrightness | Integer type | Target brightness. Range: 0 to 255, Default: 128 |
| ACL_Peak_Average | Integer type | Importance ratio for the brightness peak at ALC control. Range: 0 to 255, Default: 0 |
| ALCWeight1 ALCWeight2 ALCWeight3 ALCWeight4 ALCWeight5 ALCWeight6 ALCWeight7 ALCWeight8 ALCWeight9 | Integer type | Weight. Range: 0 to 15, Default: 1 * Set 10 on ALCWeight5 only Sets the weight for each weight area. |
| ALCWindowV1 ALCWindowV2 ALCWindowV3 ALCWindowV4 | Integer type | Vertical positions for the frame of the weight area. Range: 0 to 1,943 Default: V1 (32), V2 (680), V3 (1,264), V4 (1,912) |
| ALCWindowH1 ALCWindowH2 ALCWindowH3 ALCWindowH4 | Integer type | Horizontal positions for the frame of the weight area. Range: 0 to 2,591 Default: H1 (36), H2 (900), H3 (1,692), H4 (2,556) |

Target brightness (TargetBrightness) formula

At 12bits output: Target brightness (grayscale) = TargetBrightness * 16

At 10bits output: Target brightness (grayscale) = TargetBrightness * 4

At 8bits output: Target brightness (grayscale) = TargetBrightness

About the importance ratio for the brightens peak at ALC control (ACL Peak Average)

When 0 sets, Average: 100%, Peak: 0%. The ALC control with the brightness average.

When 255 sets, Average: 0%, Peak: 100%. The ALC control with the brightness peak.

When 128 sets, Average: 50%, Peak: 50%.

9.8.1 ALC control method

The ALC control with the weight area1 to 9.

The weight area setting parameters are in below:

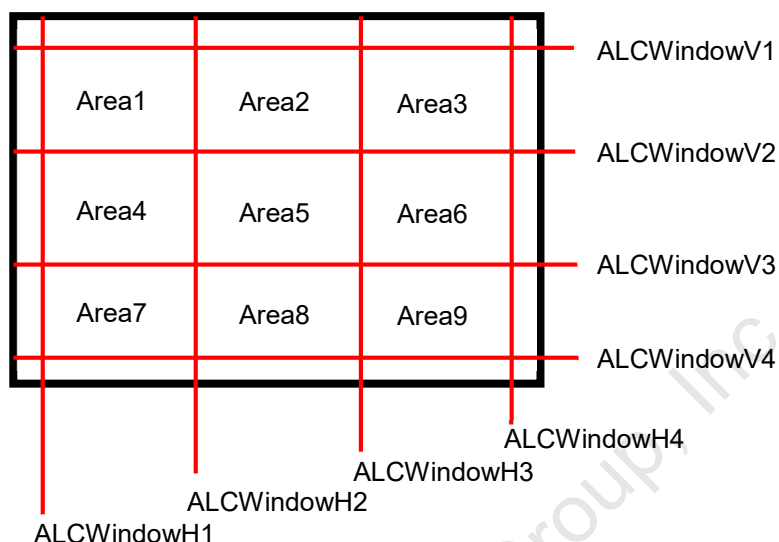

The brightness average and peak calculate for each weight area.

The target brightness comparison value calculates with "ALC_Peak_Average", the brightness average and peak then compare with the target brightness to define the necessary brightness control (to dark or to bright).

The brightness of the image maintains to the "TargetBrightness" with the AGC and the auto shutter functions.

If AGC and the auto shutter are ON for the ALC control, the auto shutter function maintains the brightness first. The AGC function maintains the brightness if the brightness cannot maintain to the TargetBrightness with the auto shutter.

9.8.2 AGC (Auto Gain Contorl)

The brightness of the image maintains to the target brightness with the gain automatically.

If the brightness of the image is the darker than the target brightness, the gain increases up to AGCRange.

If the brightness of the image is the brighter than the target brightness, the gain decreases.

GenlCam parameters

| | | |
|----------|------------------|---|
| GainAuto | Enumeration type | AGC ON / OFF selection Selection: ON (Continuous) or OFF (Off). Default: OFF |
| AGCRange | Integer type | Maximum gain. Range: 8 to 40, Default: 40 This is the maximum gain for AGC. |

9.8.3 Auto shutter

The brightness of the image maintains to the target brightness with the shutter automatically.

If the brightness of the image is the darker than the target brightness, the exposure time extends up to Max_ShutterTime.

If the brightness of the image is the brighter than the target brightness, the exposure time becomes shorter up to Min_ShutterTime.

GenICam parameters

| | | |
|-----------------|------------------|---|
| ExposureAuto | Enumeration type | Auto shutter ON / OFF selection ON (Continuous), OFF (Off). Default: OFF |
| Min_ShutterTime | Integer type | Minimum exposure time (μsecond). Range: 32 to 1,000,719 Default: 32 |
| Max_ShutterTime | Integer type | Maximum exposure time (μsecond). Range: 32 to 1,000,719 Default: 71,108 |

9.8.4 ALC settings procedure

ALC settings procedure

1. Sets ALCWeight1 to 9.
2. Sets ALCWindowV1 to 4.
3. Sets ALCWindowH1 to 4.
4. Sets TargetBrightness.
5. Sets ACL_Peak_Average.
6. Sets AGCRange if AGC is using.
7. Sets Min_ShutterTime, if the auto shutter is using.
8. Sets Max_ShutterTime, if the auto shutter is using.
9. Sets "Continuous" at GainAuto, if AGC is using.
10. Sets "Continuous" at ExposureAuto, if the auto shutter is using.

9.9 White balance (Only available for the color cameras)

The color compensates with the gain adjustment each color.

The gain for each color has to adjust with the flat white target to the each color has the same brightness.

The white balance control methods are the listed in the below:

OFF

Auto white balance

Push to set white balance

Preset1 to 3

9.9.1 White balance control methods

GenICam parameters

| | | |
|-------------------------|------------------|--|
| BalanceWhiteAuto | Enumeration type | White balance control method selection. Default: off |
| BalanceRatioSelector | Enumeration type | White balance control target color selection. |
| BalanceRatio | Float type | Color gain setting for the color selects at BalanceRatioSelector |
| YThreshold | Integer type | The brightness threshold to use the pixel for the auto white balance control. Default: 0, Range: 0 to 4,095 |
| BalanceRatio_R_Once | Integer type | R white balance gain for OFF and push to set white balance. Default: 0 |
| BalanceRatio_Gr_Once | Integer type | GR white balance gain for OFF and push to set white balance. Default: 0 |
| BalanceRatio_B_Once | Integer type | R white balance gain for OFF and push to set white balance. Default: 0 |
| BalanceRatio_Gb_Once | Integer type | Gb white balance gain for OFF and push to set white balance. Default: 0 |
| BalanceRatio_R_Preset1 | Integer type | R white balance gain for preset1. Default: 0 |
| BalanceRatio_Gr_Preset1 | Integer type | Gr white balance gain for preset1. Default: 0 |
| BalanceRatio_B_Preset1 | Integer type | B white balance gain for preset1. Default: 0 |
| BalanceRatio_Gb_Preset1 | Integer type | Gb white balance gain for preset1. Default: 0 |
| BalanceRatio_R_Preset2 | Integer type | R white balance gain for preset2. Default: 0 |
| BalanceRatio_Gr_Preset2 | Integer type | Gr white balance gain for preset2. Default: 0 |
| BalanceRatio_B_Preset2 | Integer type | B white balance gain for preset2. Default: 0 |
| BalanceRatio_Gb_Preset2 | Integer type | Gr white balance gain for preset2. Default: 0 |

GenICam parameters

| | | |
|-------------------------|--------------|--|
| BalanceRatio_R_Preset3 | Integer type | R white balance gain for preset3. Default: 0 |
| BalanceRatio_Gr_Preset3 | Integer type | Gr white balance gain for preset3. Default: 0 |
| BalanceRatio_B_Preset3 | Integer type | B white balance gain for preset3. Default: 0 |
| BalanceRatio_Gb_Preset3 | Integer type | Gb white balance gain for preset3. Default: 0 |

9.9.2 OFF

The white balance with BalanceRatio_X_Once (X: R, Gr, B or Gb)

If the white balance process is not necessary, please sets 0 for BalanceRatio_X_Once (X: R, Gr, B or Gb)

White balance "OFF" setting procedure

1. Sets Off at BalanceWhiteAuto.

9.9.3 Auto white balance

The optimized white balance gain calculates each frame for the auto white balance.

Auto white balance setting procedure

1. Sets Continuous at BalanceWhiteAuto.

9.9.4 Push to set white balance

The white balance gain adjusts once after select this white balance then set to Balance_X_Once (X: R, Gr, B or Gb)

Sets OFF at BalanceWhiteAuto automatically after set Balance_X_Once.

Push to set white balance setting procedure

1. Sets the flat white target.
2. Sets Once at BalanceWhiteAuto.

9.9.5 Preset white balance1 to 3

The camera has three preset manual white balance.

Presets saving area

Preset1: BalanceRatio_R_Preset1, BalanceRatio_Gr_Preset1,

BalanceRatio_B_Preset1, BalanceRatio_Gb_Preset1

Preset2: BalanceRatio_R_Preset2, BalanceRatio_Gr_Preset2,

BalanceRatio_B_Preset2, BalanceRatio_Gb_Preset2

Preset3: BalanceRatio_R_Preset3, BalanceRatio_Gr_Preset3,

BalanceRatio_B_Preset3, BalanceRatio_Gb_Preset3

Preset white balance setting procedure

1. Sets the white balance gain for the preset1, 2 or 3. (X: 1 to 3)

(BalanceRatio_R_PresetX, BalanceRatio_Gr_PresetX, BalanceRatio_B_PresetX, BalanceRatio_Gb_PresetX)

2. Sets PresetX (X: 1 to 3) at BalanceWhiteAuto.

Aegis Electronic Group, Inc.

9.9.6 White balance calculate area setting

The white balance gain calculation area is changeable.

GenICam parameters

| | | |
|----------------------------|------------------|---|
| WB_WindowMode | Enumeration type | White balance gain calculation area selection Full screen (Off), Specified area (On). Default: Full screen |
| WB_WindowV1 WB_WindowV2 | Integer type | Vertical frame position for the specified area. Range: 0 to 1,943 Default: V1 (0), V2 (1,943) |
| WB_WindowH1 WB_WindowH2 | Integer type | Horizontal frame position for the specified area. Range: 0 to 2,591 Default: H1 (0), H2 (2,591) |

The brightness threshold for the white balance gain calculate pixel (YThreshold)

Threshold (grayscale) = YThreshold

12bits process in the camera.

The white balance calculation area settings are below:

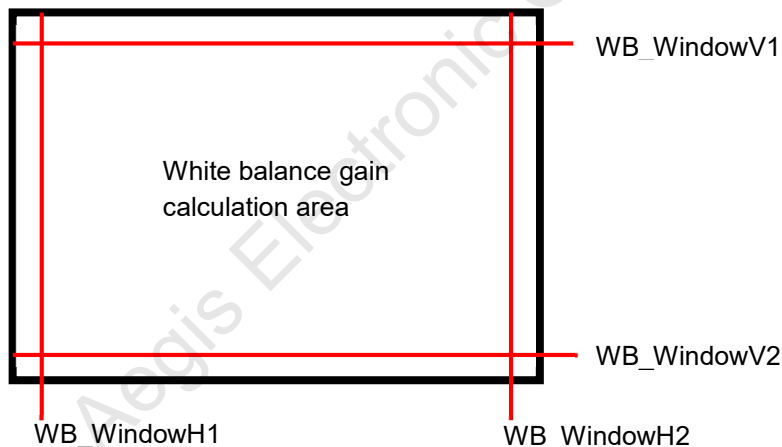

9.10 Gamma correction

The gamma correction is the gamma = 1.0 or the gamma table control.

GenICam parameters

| | | |
|-----------------|------------------|--|
| GammaMode | Enumeration type | Gamma correction selection Gamma = 1.0 (Off), Gamm table control (On). Default: Gamma = 1.0 |
| ReloadGammaData | Command type | Gamma table loading from ROM to RAM |

Gamma table loading procedure (ReloadGammaData)

1. Executes ReloadGammaData.

9.10.1 Gamma table writing

It is necessary to use the virtual com port communication (eBUS SDK: PvSerialPort class) to write the gamma table to the camera. The gamma table cannot write the camera with GenICam parameter.
Please refer the other document for the details of the gamma table writing.

Aegis Electronic Group, Inc.

9.11 Save and load the camera setting data

The camera has the camera setting including the factory default, load function.
The camera has below two camera settings.

Default: The factory default data (This data cannot change)

UserSet1: Changeable data

These camera settings load to the register in the RAM on the camera.

The camera settings saving and loading is controllable with "UserSetSelector" and "UserSetDefaultSelector" parameters, and "UserSetLoad" and "UserSetSave" commands in UserSetControl category of GenICam.

The details of the parameters and the functions are in the table below:

GenICam parameters

| | | |
|------------------------|------------------|--|
| UserSetSelector | Enumeration type | Select "Default" or "UserSet1" UserSetLoad or UserSetSave process for the selected data. |
| UserSetDefaultSelector | Enumeration type | Select which settings ("Default or UserSet1") load automatically when the camera power is on. Selection saves automatically. |
| UserSetLoad | Command type | The camera settings load from ROM to the register in RAM. |
| UserSetSave | Command type | The camera settings at the register in RAM save to ROM. |

9.11.1 The camera settings saving

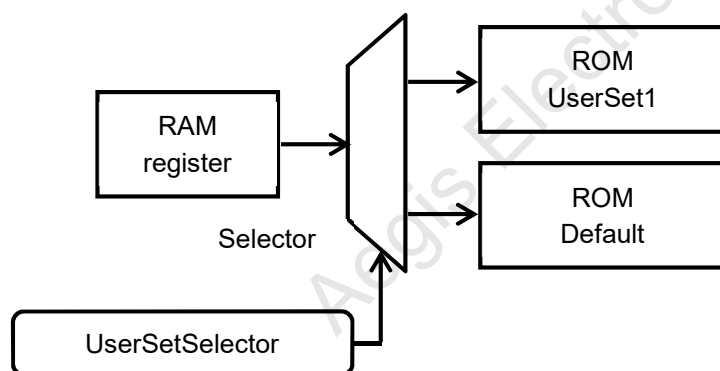

When UserSetSave is executing, the camera settings in the register at RAM, save to ROM that is selected at UserSetSelector

Caution:
UserSetSave command is only available when "UserSet1" is selected at UserSetSelector

The camera settings saving procedure

1. Selects "UserSet1" at UserSetSelector.
2. Executes UserSetSave.

9.11.2 The camera settings loading

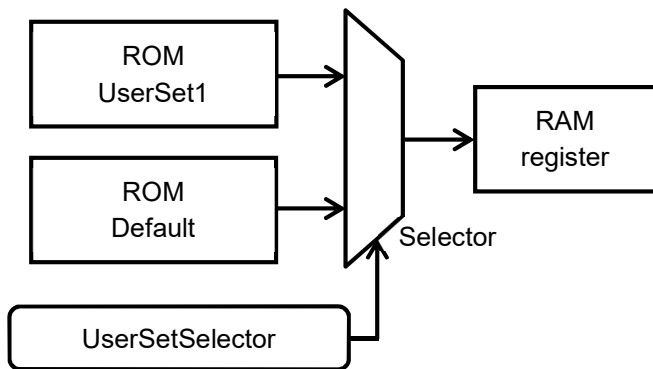

When UserSetLoad is executing, the camera settings load from the selected ROM to the register at RAM.

The camera settings loading procedure

1. Selects "UserSet1" or "Default" at UserSetSelector.
2. Executes UserSetLoad.

9.11.3 The camera settings loading when the camera power is on.

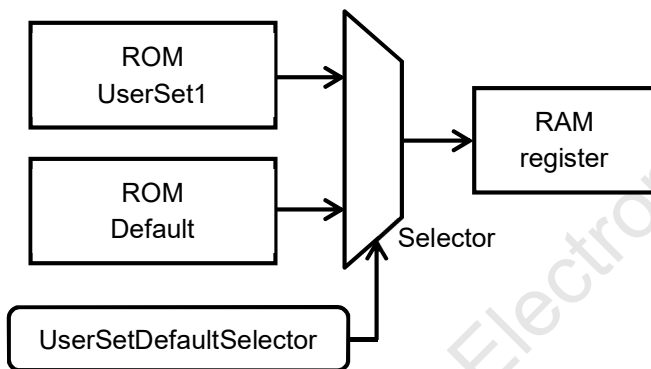

When the camera power is on, the camera settings load from the selected ROM to the register at RAM.

The camera settings loading setting for the camera power is on

1. Selects "UserSet1" or "Default" at UserSetDefaultSelector.

9.11.4 The camera settings initialization

Please follow the below procedure for the camera settings put back to the factory default. The settings of UserSet1 are overwrite with the settings of "Default".

The camera settings initialization procedure

1. Selects "Default" at UserSetSelector.
2. Executes UserSetLoad.
3. Selects "UserSet1" at UserSetSelector.
4. Executes UserSetSave.

9.12 Trigger

9.12.1 Trigger signal processing procedure

The camera internal process for the external hardware trigger signal or the software trigger signal input is below:

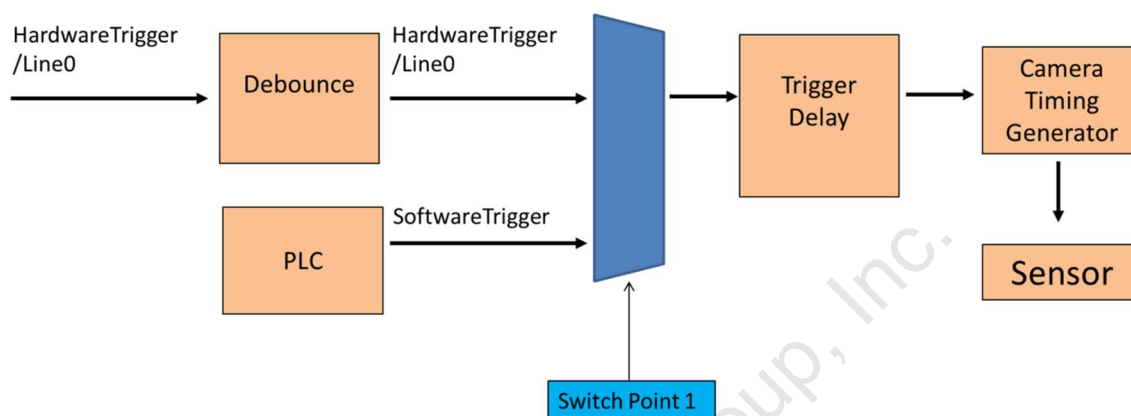

The trigger signal is selectable by the register accesses or the GenICam commands.

Switching point 1: Select the trigger signal setting for GenICam

Sets Software at TriggerSource for the software trigger signal input.

Sets Hardware at TriggerSource for the hardware =Hardware on GenICam

TriggerSource=Line0 on GenICam

9.13 The camera settings (GenICam parameters) control with SDK

GenICam parameters are controllable with the eBUS SDK.
Please refer eBUS SDK API help file for the details.

9.13.1 Integer type parameter control

Integer type parameter such as "Width" control.

e.g. Width writing

```
[C++]    PvDevice.GetGenParameters()->SetIntegerValue( "Width", 256 );
[C#]     PvDevice.GenParameters.SetIntegerValue( "Width", 256 );
```

e.g. Width reading

```
[C++]    PvDevice.GetGenParameters()->GetIntegerValue( "Width", &intValue );
[C#]     intValue = PvDevice.GenParameters.GetIntegerValue( "Width" );
```

9.13.2 Float type parameter control

Float type parameter such as "AcquisitionFrameRate" control.

e.g. AcquisitionFrameRate writing

```
[C++]    PvDevice.GetGenParameters()->SetFloatValue( "AcquisitionFrameRate", 33.3 );
[C#]     PvDevice.GenParameters.SetFloatValue( "AcquisitionFrameRate", 33.3 );
```

e.g. AcquisitionFrameRate reading

```
[C++]    PvDevice.GetGenParameters()->GetFloatValue( "AcquisitionFrameRate", &doubleValue );
[C#]     doubleValue = PvDevice.GenParameters.GetFloatValue( "AcquisitionFrameRate" );
```

9.13.3 Enumeration type parameter control

Enumeration type parameter such as "BalanceWhiteAuto" control.

e.g. BalanceWhiteAuto writing

```
[C++]    PvDevice.GetGenParameters()->SetEnumValue( "BalanceWhiteAuto", "Continuous" );
[C#]     PvDevice.GenParameters.SetEnumValue( "BalanceWhiteAuto", "Continuous" );
```

e.g. BalanceWhiteAuto reading

```
[C++]    PvDevice.GetGenParameters()->GetEnumValue( "BalanceWhiteAuto", &PvStringValue );
[C#]     stringValue = PvDevice.GenParameters.GetEnumValueAsString( "BalanceWhiteAuto" );
```

9.13.4 String type parameter control

String type parameter such as "DeviceModelName" control.

e.g. DeviceModelName writing (DeviceModelName cannot overwrite)

```
[C++]    PvDevice.GetGenParameters()->SetString( "DeviceModelName", "STC-SB33POE" );
[C#]     PvDevice.GenParameters.SetStringValue( "DeviceModelName", "STC-SB33POE" );
```

e.g. DeviceModelName reading

```
[C++]    PvDevice.GetGenParameters()->GetString( "DeviceModelName", &PvStringValue );
[C#]     stringValue = PvDevice.GenParameters.GetStringValue( "DeviceModelName" );
```

9.13.5 Boolean type parameter control

Boolean type parameter such as "LineInverter0" control.

e.g. LineInverter0 writing

```
[C++]    PvDevice.GetGenParameters()->SetBooleanValue( "LineInverter0", true );
[C#]     PvDevice.GenParameters.SetBooleanValue( "LineInverter0", true );
```

e.g. LineInverter0 reading

```
[C++]    PvDevice.GetGenParameters()->GetBooleanValue( "LineInverter0", &boolValue );
[C#]     boolValue = PvDevice.GenParameters. GetBooleanValue( "LineInverter0" );
```

9.13.6 Command type parameter control

Command type parameter such as "TriggerSoftware"

e.g. TriggerSoftware generating

```
[C++]    PvDevice.GetGenParameters()->ExecuteCommand( "TriggerSoftware" );
[C#]     PvDevice.GenParameters.ExexuteCommand( "TriggerSoftware" );
```

9.14 GenICam Command List

9.14.1 DeviceControl

| Name | Description |
|------------------------|--|
| DeviceVendorName | Name of the manufacturer of the device. |
| DeviceModelName | Model of the device. |
| DeviceManufacturerInfo | Manufacturer information about the device. |
| DeviceVersion | Version of the device. |
| DeviceID | Device's serial number. |
| DeviceUserID | User-programmable device identifier. |
| DeviceScanType | Scan type of the sensor of the device. |
| DeviceTemperature | Device temperature in degrees Celsius (C). |
| DeviceReset | Reset the device to its power up state. |

9.14.2 ImageFormatControl

| Name | Description |
|------------------------|--|
| SensorDigitizationTaps | Number of digitized samples outputted simultaneously by the camera A/D conversion stage. |
| Width | Width of the image provided by the device (in pixels). |
| Height | Height of the image provided by the device (in pixels). |
| SensorShutterMode | Sets the shutter mode of the device. |
| DecimationHorizontal | Horizontal sub-sampling of the image. This reduces the horizontal resolution (width) of the image by the specified horizontal decimation factor. |
| DecimationVertical | Vertical sub-sampling of the image. This reduces the vertical resolution (height) of the image by the specified vertical decimation factor. |
| RegionSelector | Selects the Region of interest to control. The RegionSelector feature allows devices that are able to extract multiple regions out of an image, to configure the features of those individual regions independently. |
| ReverseX | This feature is used to flip horizontally the image sent by the device. The AOI is applied after the flipping. |
| ReverseY | This feature is used to flip vertically the image sent by the device. The AOI is applied after the flipping. |
| PixelFormat | Format of the pixels provided by the device. It represents all the information provided by PixelCoding, PixelSize, PixelColorFilter combined in a single feature. |
| PixelCoding | Coding of the pixels in the image, Raw gives the data in the native format of the sensor. |
| PixelSize | Total size in bits of a pixel of the image. |
| PixelColorFilter | Type of color filter that is applied to the image. |
| TestImageSelector | Selects the type of test image that is sent by the camera. |
| OffsetX | Horizontal offset from the origin to the region of interest (in pixels). |
| OffsetY | Vertical offset from the origin to the region of interest (in pixels). |

9.14.3 AcquisitionControl

| Name | Description |
|-----------------------|--|
| AcquisitionMode | Sets the acquisition mode of the device. It defines mainly the number of frames to capture during an acquisition and the way the acquisition stops. |
| AcquisitionStart | Starts the Acquisition of the device. The number of frames captured is specified by AcquisitionMode. |
| AcquisitionStop | Stops the Acquisition of the device at the end of the current Frame. It is mainly used when AcquisitionMode is Continuous but can be used in any acquisition mode. |
| AcquisitionFrameCount | Number of frames to acquire in MultiFrame Acquisition mode. |
| AcquisitionFrameRate | Controls the acquisition rate (in Hertz) at which the frames are captured. |
| TriggerSelector | Selects the type of trigger to configure. |
| TriggerMode | Controls if the selected trigger is active. |
| TriggerSoftware | Generates an internal trigger. TriggerSource must be set to Software. |
| TriggerSource | Specifies the internal signal or physical input Line to use as the trigger source. The selected trigger must have its TriggerMode set to On. |
| TriggerActivation | Specifies the activation mode of the trigger. |
| TriggerDelay | Specifies the delay in microseconds (us) to apply after the trigger reception before activating it. |
| ExposureMode | Sets the operation mode of the Exposure (or shutter). |
| ExposureTime | Sets the Exposure time when ExposureMode is Timed and ExposureAuto is Off. This controls the duration where the photosensitive cells are exposed to light. |
| ExposureTimeAbs | Sets the Exposure time when ExposureMode is Timed and ExposureAuto is Off. This controls the duration where the photosensitive cells are exposed to light. |
| ExposureTimeRaw | Sets the Exposure time when ExposureMode is Timed and ExposureAuto is Off. This controls the duration where the photosensitive cells are exposed to light. |
| ExposureAuto | Sets the automatic exposure mode when ExposureMode is Timed. The exact algorithm used to implement this control is device-specific. |

9.14.4 DigitalIOControl

| Name | Description |
|--------------------|--|
| LineDebounceTime | Sets the value of the input line debouncer time. |
| LineSource0 | Set the output signals from the power / IO connector. |
| LineSource1 | Set the output signals from the power / IO connector. |
| UserOutputValue0 | Sets the value of the bit selected by LineSource0. |
| UserOutputValue1 | Sets the value of the bit selected by LineSource1. |
| StrobeSignalDelay | Specifies the delay in microseconds (us) to apply the trigger reception before activating strobe signal. |
| StrobeSignalOnTime | Specifies the strobe signal active time in microseconds (us). |
| LineInverter0 | Controls the inversion of the signal of the selected output line of LineSource0. |
| LineInverter1 | Controls the inversion of the signal of the selected output line of LineSource1. |

9.14.5 CounterAndTimerControl

| Name | Description |
|-----------------------------|---|
| CounterSelector | Selects which Counter to configure. |
| CounterEventSource | Select the events that will be the source to increment the Counter. |
| CounterDecrementEventSource | Selects the event that decrements the counter. |
| CounterResetSource | Selects the signals that will be the source to reset the Counter. |
| CounterResetActivation | Selects the Activation mode of the Counter Reset Source signal. |
| CounterValue | Reads or writes the current value of the selected Counter. |
| CounterDuration | Sets the duration (or number of events) before the CounterEnd event is generated. |
| CounterStatus | Returns the current status of the Counter. |
| CounterTriggerSource | Selects the source to start the Counter. |
| TimerSelector | Selects which Timer to configure. |
| TimerDurationRaw | It sets the duration in device-specific unit of the Timer pulse. |
| TimerDelayRaw | It sets the duration in device-specific unit of the delay to apply after the reception of a trigger before start the Timer. |
| TimerTriggerSource | Selects the source of the trigger to start the Timer. |
| TimerTriggerActivation | Selects the activation mode of the trigger to start the Timer. |
| TimerGranularityFactor | Controls the granularity of the TimerDurationRaw and TimerDelayRaw features (in increments of up to 30 nseconds). |
| TimerPeriod | Returns the period, in ns, of the selected timer. |
| TimerFrequency | Returns the frequency, in Hertz, of the selected timer. |

9.14.6 EventControl

| Name | Description |
|-----------------------------|--|
| PLC | Category that contains the PLC event features. |
| IPEngineCamHeadSerialComLog | Category that contains the IP engine to camera head serial communication log event features. |
| EventSelector | Selects which Event to signal to the host application. |
| EventNotification | Activate or deactivate the notification to the host application of the occurrence of the selected Event. |

9.14.7 AnalogControl

| Name | Description |
|--------------------|--|
| GainSelector | Selects which Gain is controlled by the various Gain features. |
| Gain | Controls the selected gain as an absolute physical value. This is an amplification factor applied to the video signal. |
| GainRaw | Controls the selected gain as an absolute physical value. This is an amplification factor applied to the video signal. |
| GainAbs | Controls the selected gain as an absolute physical value. This is an amplification factor applied to the video signal. |
| GainAuto | Sets the automatic gain control (AGC) mode. The exact algorithm used to implement AGC is device-specific. |
| BlackLevelSelector | Selects which Black Level is controlled by the various Black Level features. |
| BlackLevel | Controls the black level as an absolute physical value. This represents a DC offset applied to the video signal. |

9.14.8 TransportLayerControl

| Name | Description |
|-------------------------------------|--|
| PayloadSize | Provides the number of bytes transferred for each image or chunk on the stream channel. |
| GevVersionMajor | Major version of the specification. |
| GevVersionMinor | Minor version of the specification. |
| GevVDeviceModelsBigEndian | Endianess of the device registers. |
| GevDeviceClass | Returns the class of the device. |
| GevDeviceModeCharacterSet | Character set used by all strings of the bootstrap registers. |
| GevInterfaceSelector | Selects which physical network interface to control. |
| GevMACAddress | MAC address of the network interface. |
| GevSupportedOptionSelector | Selects the GEV option to interrogate for existing support. |
| GevSupportedOption | Returns if the selected GEV option is supported. |
| GevCurrentIPConfigurationLLA | Controls whether the Link Local Address IP configuration scheme is activated on the given network interface. |
| GevCurrentIPConfigurationDHCP | Controls whether the DHCP IP configuration scheme is activated on the given network interface. |
| GevCurrentIPConfigurationPersistent | Controls whether the Persistent IP configuration scheme is activated on the given network interface. |
| GevCurrentIPAddress | Reports the IP address for the given network interface. |
| GevCurrentSubnetMask | Reports the subnet mask of the given network interface. |
| GevCurrentDefaultGateway | Reports the default gateway IP address to be used on the given network interface. |
| GevIPConfigurationStatus | Reports the current IP configuration status. |
| GevFirstURL | Indicates the first URL to the XML device description file. |
| GevSecondURL | Indicates the second URL to the XML device description file. |
| GevNumberOfInterface | Indicates the number of physical network interfaces supported by this device. |
| GevPersistentIPAddress | Controls the Persistent IP address for this network interface. |
| GevPersistentSubnetMask | Controls the Persistent subnet mask associated with the Persistent IP address on this network interface. |
| GevPersistentDefaultGateway | Controls the Persistent default gateway for this network interface. |
| GevMessageChannelCount | Indicates the number of message channels supported by this device. |
| GevStreamChannelCount | Indicates the number of stream channels supported by this devices. |
| GevHeartbeatTimeout | Controls the current heartbeat timeout in milliseconds. |
| GevTimestampCounterSelector | Selects the source counter for GigE Vision timestamps. |
| GevTimestampSetSource | Selects the signal that sets the counter to GevTimestampValueAtSet. |
| GevTimestampSetActivation | Selects the activation mode for the counter set source signal. |
| GevTimestampValueAtSet | Controls the value to be set in the counter when the set event occurs. |
| GevTimestampResetSource | Selects the signal that resets the counter (to 0). |
| GevTimestampResetActivation | Selects the activation mode for the counter reset source signal. |
| GevTimestampTickFrequency | Indicates the number of timestamp ticks in 1 second (frequency in Hz). |
| GevTimestampControlLatch | Latches the current timestamp counter into GevTimestampValue. |
| GevTimestampControlSet | Sets the counter to GevTimestampValueAtSet. |
| GevTimestampControlReset | Rests the timestamp counter to 0. |
| GevTimestampValue | Returns the latched 64-bits value of the timestamp counter. |
| GevCCP | Controls the device access privilege of an application. |
| GevMCPHostPort | Controls the port to which the device must send message. |
| GevMCDA | Controls the destination IP address for the message channel. |

| Name | Description |
|-------------------------|---|
| GevMCTT | Provides the transmission timeout value in milliseconds. |
| GevMCRC | Controls the number of retransmissions allowed when a message channel message time out. |
| GevMCSP | This feature indicates the source port for the message channel. |
| GevStreamChanelSelector | Selects the stream channel to control. |
| GevSCPDirection | Reports the direction of the stream channel. |
| GevSCPInterfaceIndex | Index of network interface to use. |
| GevSCPHostPort | Controls the port of the selected channel to which a GVSP transmitter must send data stream or the port from which a GVSP receiver may receive data stream. |
| GevSCPFireTestPacket | Sends a test packet. |
| GevSCPSPDoNotFragment | The state of this feature is copied into the "do not fragment" bit of IP header of each stream packet. |
| GevSCPSPBigEndian | Endianess of multi-bytes pixel data for this stream. |
| GevSCPSPPacketSize | Specifies the stream packet size, in bytes, to send on the selected channel for a GVSP transmitter or specifies the maximum packet size supported by a GVSP receiver. |
| GevSCPD | Controls the delay (in timestamp counter unit) to insert between each packet for this stream channel. |
| GevSCDA | Controls the destination IP address of the selected stream channel to which a GVSP transmitter must send data stream or this destination IP address from which a GVSP receiver may receive data stream. |
| GevSCSP | Indicates the source port of the stream channel. |

9.14.9 UserSetControl

| Name | Description |
|------------------------|---|
| UserSetSelector | Selects the feature User Set to load, save or configure. |
| UserSetLoad | Loads the User Set specified by UserSetSelector to the device and makes it active. |
| UserSetSave | Save the User Set specified by UserSetSelector to the non-volatile memory of the device. |
| UserSetDefaultSelector | Selects the feature User Set to load and make active by default when the device is reset. |

9.14.10 IPEngine

| Name | Description |
|-----------------------------|--|
| ProgrammableLogicController | Category that contains the Programmable Logic Controller (PLC) features. |

9.14.11 SpecialFeatures

| Name | Description |
|------------------|---|
| ReloadGammaData | Gamma table reload from EEPROM to RAM. |
| GammaMode | Gamma mode selection. |
| Min_ShutterTime | Minimum shutter speed for Auto shutter control mode. Unit: us. |
| Max_ShutterTime | Maximum shutter speed for Auto shutter control mode. Unit: us |
| AGCRange | Maximum gain value for AGC. |
| TargetBrightness | Target brightness for ALC. |
| ALC_Peak_Average | Ratio of peak and average fro ALC. |
| DigitalGain | Digital gain |
| ALCWeight1 | Weight of the area determined by ALCWindowV1, ALCWindowV2, ALCWindowH1 and ALCWindowH2 for ALC. |
| ALCWeight2 | Weight of the area determined by ALCWindowV1, ALCWindowV2, ALCWindowH2 and ALCWindowH3 for ALC. |
| ALCWeight3 | Weight of the area determined by ALCWindowV1, ALCWindowV2, ALCWindowH3 and ALCWindowH4 for ALC. |
| ALCWeight4 | Weight of the area determined by ALCWindowV2, ALCWindowV3, ALCWindowH1 and ALCWindowH2 for ALC. |
| ALCWeight5 | Weight of the area determined by ALCWindowV2, ALCWindowV3, ALCWindowH2 and ALCWindowH3 for ALC. |
| ALCWeight6 | Weight of the area determined by ALCWindowV2, ALCWindowV3, ALCWindowH3 and ALCWindowH4 for ALC. |
| ALCWeight7 | Weight of the area determined by ALCWindowV3, ALCWindowV4, ALCWindowH1 and ALCWindowH2 for ALC. |
| ALCWeight8 | Weight of the area determined by ALCWindowV3, ALCWindowV4, ALCWindowH2 and ALCWindowH3 for ALC. |
| ALCWeight9 | Weight of the area determined by ALCWindowV3, ALCWindowV4, ALCWindowH3 and ALCWindowH4 for ALC. |
| ALCWindowV1 | 1st vertical line (1st from the top) position for the area for ALC. |
| ALCWindowV2 | 2nd vertical line (2nd from the top) position for the area for ALC. |
| ALCWindowV3 | 3rd vertical line (3rd from the top) position for the area for ALC. |
| ALCWindowV4 | 4th vertical line (4th from the top) position for the area for ALC. |
| ALCWindowH1 | 1st horizontal (1st from the left) position for the area for ALC. |
| ALCWindowH2 | 2nd horizontal (2nd from the left) position for the area for ALC. |
| ALCWindowH3 | 3rd horizontal (3rd from the left) position for the area for ALC. |
| ALCWindowH4 | 4th horizontal (4th from the left) position for the area for ALC. |
| WB_WindowH1 | Horizontal start position of the area for auto white balance (Horizontal start position from left) |
| WB_WindowH2 | Horizontal end position of the area for auto white balance (Horizontal end position from left) |
| WB_WindowV1 | Vertical start position of the area for auto white balance (Vertical start position from left) |
| WB_WindowV2 | Vertical end position of the area for auto white balance (Vertical end position from left) |
| WB_WindowMode | Select white balance window mode. |
| YThreshold | The value for auto white balance is determined with the color information of the pixels, which is more than this threshold. |
| ModeCode | Mode code. |
| HardwareVersion | Hardware version. |

| Name | Description |
|---------------------|------------------------|
| FPGAFirmwareVersion | FPGA Firmware Version. |
| FirmwareVersion | Firmware Version. |
| SerialNumber | Serial number. |
| CustomerCode | Customer code. |

Aegis Electronic Group, Inc.

10 Revision History

| Rev | Date | Changes | Note |
|-----|------------|---|------|
| 00 | 2014/07/21 | ● New Document | |
| 01 | 2016/03/14 | ● Revised: Camera Mount Screws | |
| 02 | 2017/04/17 | ● Revised Address, TEL, FAX number for relocation | |
| 03 | 2017/07/03 | ● Revised Change the name of company | |
| 04 | 2018/09/03 | ● Revised Changes the electronic specifications list (Image output format) Adds IR Cut Filter information | |
| 05 | 2019/02/27 | ● Revised Added trademark information | |

GigE Vision is trademark of AIA.

GenICam is trademark of EMVA.

Other company names and product names in this document are trademarks of their respective owners.

Aegis Electronic Group, Inc.

OMRON SENTECH CO., LTD.

 (888)687-6877
ELECTRONIC GROUP, INC
