GigE Vision

Color / Monochrome CMOS PoE Camera

STC-CMB2MPOE (2M / Monochrome)

STC-CMC2MPOE (2M / Color)

STC-CMB2MPOE-IR (2M / Near IR)

STC-CMB4MPOE (4M / Monochrome)

STC-CMC4MPOE (4M / Color)

STC-CMB4MPOE-IR (4M / Near IR)

Product Specifications and User's Guide

OMRON SENTECH CO., LTD.

Table of Contents

1	Product Precautions	7
2	Warranty.....	7
3	Introduction	8
3.1	Features	8
3.2	Product Number Naming Method	8
4	Specifications.....	9
4.1	Electronic Specifications.....	9
4.1.1	STC-CMB2MPOE / STC-CMC2MPOE	9
4.1.2	STC-CMB4MPOE / STC-CMC4MPOE	10
4.1.3	STC-CMB2MPOE-IR / STC-CMB4MPOE-IR.....	11
4.2	Spectral Sensitivity Characteristics	12
4.2.1	STC-CMB2MPOE / STC-CMB4MPOE	12
4.2.2	STC-CMC2MPOE / STC-CMC4MPOE	12
4.2.3	STC-CMB2MPOE-IR / STC-CMB4MPOE-IR (Near IR Model).....	13
4.3	Mechanical Specifications.....	14
4.4	Environmental Specifications	14
5	Connector Specifications	15
5.1	RJ45 Connector.....	15
5.2	Power and Control Signal Connector.....	16
5.2.1	Equivalent Circuit for the Input Pin of the I/O Connector.....	18
5.2.2	Typical Input Circuit.....	19
5.2.3	Typical Output Circuit.....	20
5.2.4	Input and Output Signal Timing (Hardware Trigger).....	21
5.2.5	Input and Output Signal Timing (Software Trigger).....	22
6	Dimensions.....	23
7	Sensor information	24
7.1	Pixel Transferring Image.....	24

8	Camera Operational Modes	25
8.1	Normal Mode.....	25
8.2	Pulse width trigger mode.....	25
8.2.1	Timing.....	25
8.2.2	Exposure Timing with the Positive Polarity Trigger Signal.....	26
8.2.3	Exposure Timing with the Negative Polarity Trigger Signal	26
8.3	Edge Preset Trigger Mode	27
8.3.1	Timing.....	27
8.3.2	Exposure Timing with the Positive Polarity Trigger Signal.....	28
8.3.3	Exposure Timing with the Negative Polarity Trigger signal.....	28
8.4	Edge Preset Trigger Mode (Trigger Input While the Image Is Out).....	29
8.4.1	Timing.....	29
9	Camera Functions	30
9.1	ROI (Region of Interest)	30
9.1.1	ROI (1 region).....	30
9.2	Pixel Format.....	32
9.3	Binning.....	32
9.4	Gain	33
9.4.1	Digital gain	33
9.5	Black level.....	33
9.6	ALC (Auto Light Control)	34
9.6.1	ALC control method.....	35
9.6.2	AGC (Auto Gain Contorl).....	35
9.6.3	Auto shutter	36
9.6.4	ALC settings procedure	36
9.7	White balance (Only available for the color cameras)	37
9.7.1	White balance control methods	37
9.7.2	OFF	38
9.7.3	Auto white balance	38
9.7.4	Push to set white balance	38
9.7.5	Preset white balance1 to 3	39
9.7.6	White balance calculate area setting.....	40
9.8	Gamma correction.....	41
9.8.1	Gamma table writing.....	41
9.9	Save and load the camera setting data	42

9.9.1	Saving the Camera Settings	42
9.9.2	Loading Camera Settings	43
9.9.3	Loading Camera Settings when the Camera Power is on	43
9.9.4	Camera Settings Initialization	43
9.10	Trigger	44
9.10.1	Trigger Signal Processing Process	44
9.11	The camera settings (GenICam parameters) control with SDK.....	45
9.11.1	Integer type parameter control	45
9.11.2	Float type parameter control.....	45
9.11.3	Enumeration type parameter control	45
9.11.4	String type parameter control.....	46
9.11.5	Boolean type parameter control	46
9.11.6	Command type parameter control.....	46
9.12	GenICam Command List.....	47
9.12.1	DeviceControl	47
9.12.2	ImageFormatControl.....	47
9.12.3	AcquisitionControl	48
9.12.4	DigitalIOControl	48
9.12.5	CounterAndTimerControl.....	49
9.12.6	EventControl	49
9.12.7	AnalogControl.....	49
9.12.8	TransportLayerControl	50
9.12.9	UserSetControl	51
9.12.10	IPEngine	51
9.12.11	SpecialFeatures	52
10	Revision History	54

Precautions for safe use

Please read carefully this "Precautions for safe use" before use the camera. Then the camera uses correctly with agreeing with below notes.

In this "Precautions for safe use", notes divides into "Warning" and "Caution" to use the camera safety and prevent to harm and damage.

Warning	This shows, assumption for possibility of serious accident leading death or serious injury if ignore this note and camera uses incorrectly.
Caution	This shows, assumption for possibility of bear the damage or physical damage if ignore this note and camera uses incorrectly.

About Graphic symbols



This symbol shows general prohibition.







This symbol shows completion or instruction.

[Environment / condition]









Warning	
Do not use flammable or explosiveness atmospheres. This will cause of personal injury or fire.	Do not use for "safety for human body" related usage. This camera is designed for use "do not harm human body immediately" if by any chance the camera has malfunction.
Caution	
Use and store under specified environmental conditions (Vibration, shock, temperature, humidity) in the specifications for this camera. This will cause of fire or damage the camera.	

[Installation and cable wiring]



Warning	
Do not use with out of power voltage range that is specified in the specifications for this camera. This will cause of fire, electrification or malfunction.	Do not wrong wiring. This will cause of fire or malfunction.

 Caution	
 The camera housing is not connecting to 0 V line of camera inside circuit. There is a risk of short circuit between camera inside circuit and frame ground through other devices. This will cause of malfunction.	 It is necessary to wiring and mounting that is specified in the specifications for this camera. This will cause of fire or malfunction.
 It is necessary to wiring with turn off the camera. This will cause of electrification or malfunction.	 It is necessary to mounting the camera without stress for the cable. This will case of electrification or fire.



[Usage instruction]

 Warning	
 Do not touch the terminal and PCB board While turn on the camera. This will cause of electrification or accident caused by malfunction.	 Do not put combustibles near the camera. This will cause of fire.
 Do not use without usage that is specified in the specifications for this camera. This will cause of personal injury or malfunction.	 Do not push metals including screw driver into radiation holes. This will cause of electrification or malfunction.
 Caution	
 Do not push contamination into opening of the camera. This will cause of electrification or malfunction.	 Do not block the radiation holes. This will cause of fire due to increase the camera inside temperature.

[Maintenance]

 Caution	
 Do not disassemble or repair the camera. This will cause of fire, electrification or malfunction.	 It is turn off the camera when maintaining or inspecting the camera. This will cause of electrification.

[Disposal]

 Caution	
 It is necessary to dispose as industrial waste.	

1 Product Precautions

- Do not give shock to the camera.
- Do not haul or damage the camera cable.
- Do not wrap the camera with any material while using the camera. This will cause the internal camera temperature to increase.
- When the camera moving or using the place that temperature difference is extreme, countermeasure for dew condensation (heat removal / cold removal) is necessary.
- While the camera is not using, keep the lens cap on the camera to prevent dust or contamination from getting in the sensor or filter and scratching or damaging it.

Do not keep the camera under the following conditions.

- In wet, moist, high humidity or dusty place
- Under direct sunlight
- In extreme high or low temperature place
- Near an object that releases a strong magnetic or electric field
- Place with strong vibrations
- Apply the power that satisfies the specified in specifications for the camera.
- The defective pixels may appear due to the sensor characteristics.
- Use below recommend materials (or equivalent materials) to clean the surface of glass.
 - Air dust: Non Freon air duster (NAKABAYASHI Co., LTD.)
 - Alcohol: Propan-2-ol (SAN'EI KAKO Co., LTD.)
 - Non-woven: nikowipe clean room (NKB)
- Use a soft cloth to clean the camera.

2 Warranty

■Warranty period

One year after delivery (However, the camera had malfunction with camera uses correctly)

In below case for a fee even within warranty period.

- The malfunction caused by incorrect usage, incorrect modify or repair.
- The malfunction caused by external shock including the camera dropping after delivery the camera.
- The malfunction caused by fire, earthquake, flood disaster, thunderbolt struck, other natural disaster or wrong voltage.

■Warranty coverage

Exchange or repair the malfunction camera if the malfunction is occurred by our responsibility.

“Warranty” mean is warranty for the delivered camera itself. Please accept the induction damage by the camera malfunction is not included.

3 Introduction

This document describes the specification of the following cameras:

STC-CMB2MPOE / STC-CMC2MPOE / STC-CMB2MPOE-IR
 STC-CMB4MPOE / STC-CMC4MPOE / STC-CMB4MPOE-IR

3.1 Features

- Support PoE (Power over Ethernet Support)
- Maximum Frame Rate (Full Scanning): 50 fps @ 2M 8bits, 25 fps @ 4M 8bits
- CMOS (Global Shutter)
- Defective Pixel Correction up to 64 points
- 8bits or 10bits output

3.2 Product Number Naming Method

STC-CM_x2MPOE-x

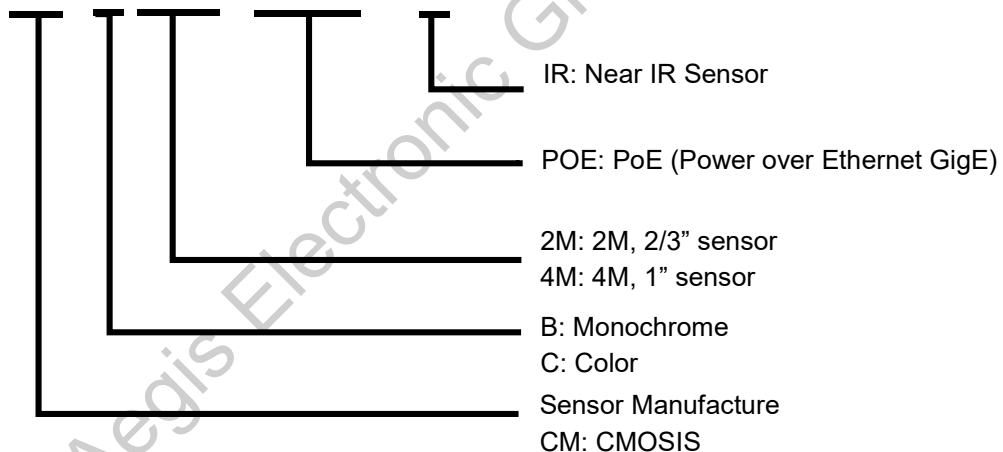

4 Specifications

4.1 Electronic Specifications

4.1.1 STC-CMB2MPOE / STC-CMC2MPOE

Model Number		STC-CMB2MPOE	STC-CMC2MPOE
Image Sensor		2/3" 2M Progressive Monochrome CMOS (CMOSIS: CMV2000)	2/3" 2M Progressive Color CMOS (CMOSIS: CMV2000)
Shutter Type		Global Shutter	
Active Picture Elements		2,048 (H) x 1,088 (V)	
Cell Size		5.5 (H) x 5.5 (V) μm	
Sync Method		External trigger (Hardware / Software) / Free run	
Maximum Frame Rate (at Full scanning)	8bits output	50 fps	
	10bits output	25 fps	
	10bits Packed output	34 fps	
Image Output Format		Mono8 / Mono10 / Mono10Packed	BayerGB8 / BayerGB10 / BayerGB10Packed
Noise Level	8bits output	Less than 2.5 Digits (Gain 0 dB)	
	10bits / 10bits Packed output	Less than 15 Digits (Gain 0 dB)	
Minimum Scene Illumination		Less than 1 Lux at F1.2, 50 Hz	
Exposure Time	8bits output	24 $\mu\text{seconds}$ to 20 seconds (Default: 24 $\mu\text{seconds}$)	
	10bits output		
	10bits Packed output		
Gain	Analog	N/A	
	Digital	x1 to x5 (Default: x1)	
ROI		Horizontal: 8 to 2,048 pixels / Vertical: 4 to 1,088 lines (Default: 2,048 x 1,088) Adjustable steps for image size: 8 pixels in horizontal direction / 2 lines in vertical direction Adjustable steps for offset: 8 pixels in horizontal direction / 2 lines in vertical direction	
Multi ROIs		N/A	
Gamma		Gamma 1.0 (Factory default) or uploadable gamma table (Default: 1)	
HDR		Support	
Binning		Horizontal: 1/2, Vertical: 1/2 / Off	N/A
Decimation		N/A	
Flip Image		N/A	
Pixel Blemish Correction		Up to 64 points	
Auto Image Control	Auto Exposure	Support	Support
	Auto Gain (AGC)	Support	Support
	Auto White Balance	N/A	Support
Operational Mode		Edge preset trigger / Pulse width trigger / Free run	
Communication		UART communication through Ethernet port	
Interface		IEEE802.3 (1000BASE-T)	
Protocol		GigE Vision 1.2 GenICam 2.0	
I/O		One opt-isolated input and two open collector outputs (+3.3 V)	
Power	Input Voltage	+10.8 to +26.4 Vdc (IO Connector) or Power Over Ethernet (IEEE802.3af compliance)	
	Consumption	Less than 3.6 W	

Default: **Bold**

4.1.2 STC-CMB4MPOE / STC-CMC4MPOE

Model Number		STC-CMB4MPOE	STC-CMC4MPOE
Image Sensor		1" 4M Progressive Monochrome CMOS (CMOSIS: CMV2000)	1" 4M Progressive Color CMOS (CMOSIS: CMV4000)
Shutter Type		Global Shutter	
Active Picture Elements		2,048 (H) x 2,048 (V)	
Cell Size		5.5 (H) x 5.5 (V) μm	
Sync Method		External trigger (Hardware / Software) / Free run	
Maximum Frame Rate (at Full scanning)	8bits output	25 fps	
	10bits output	13.5 fps	
	10bits Packed output	17.5 fps	
Image Output Format		Mono8 / Mono10 / Mono10Packed	BayerGB8 / BayerGB10 / BayerGB10Packed
Noise Level	8bits output	Less than 2.5 Digits (Gain 0 dB)	
	10bits / 10bits Packed output	Less than 15 Digits (Gain 0 dB)	
Minimum Scene Illumination		Less than 1 Lux at F1.2, 50 Hz	
Exposure Time	8bits output	24 $\mu\text{seconds}$ to 20 seconds (Default: 24 $\mu\text{seconds}$)	
	10bits output		
	10bits Packed output		
Gain	Analog	N/A	
	Digital	x1 to x5 (Default: x1)	
ROI		Horizontal: 8 to 2,048 pixels / Vertical: 4 to 2,048 lines (Default: 2,048 x 2,048) Adjustable steps for image size: 8 pixels in horizontal direction / 2 lines in vertical direction Adjustable steps for offset: 8 pixels in horizontal direction / 2 lines in vertical direction	
Multi ROIs		N/A	
Gamma		Gamma 1.0 (Factory default) or uploadable gamma table (Default: 1)	
HDR		Support	
Binning		Horizontal: 1/2, Vertical: 1/2 / Off	N/A
Decimation		N/A	
Flip Image		N/A	
Pixel Blemish Correction		Up to 64 points	
Auto Image Control	Auto Exposure	Support	Support
	Auto Gain (AGC)	Support	Support
	Auto White Balance	N/A	Support
Operational Mode		Edge preset trigger / Pulse width trigger / Free run	
Communication		UART communication through Ethernet port	
Interface		IEEE802.3 (1000BASE-T)	
Protocol		GigE Vision 1.2 GenICam 2.0	
I/O		One opt-isolated input and two open collector outputs (+3.3 V)	
Power	Input Voltage	+10.8 to +26.4 Vdc (IO Connector) or Power Over Ethernet (IEEE802.3af compliance)	
	Consumption	Less than 3.6 W	

Default: **Bold**

4.1.3 STC-CMB2MPOE-IR / STC-CMB4MPOE-IR

Model Number		STC-CMB2MPOE-IR	STC-CMB4MPOE-IR
Image Sensor		2/3" 2M Progressive Near IR CMOS (CMOSIS: CMV2000)	1" 4M Progressive Near IR CMOS (CMOSIS: CMV4000)
Shutter Type		Global Shutter	
Active Picture Elements		2,048 (H) x 1,088 (V)	2,048 (H) x 2,048 (V)
Cell Size		5.5 (H) x 5.5 (V) μ m	
Sync Method		External trigger (Hardware / Software) / Free run	
Maximum Frame Rate (at Full scanning)	8bits output	50 fps	25 fps
	10bits output	25 fps	13.5 fps
	10bits Packed output	34 fps	17.5 fps
Image Output Format		Mono8 / Mono10 / Mono10Packed	
Noise Level	8bits output	Less than 2.5 Digits (Gain 0 dB)	
	10bits / 10bits Packed output	Less than 15 Digits (Gain 0 dB)	
Minimum Scene Illumination		Less than 1 Lux at F1.2, 50 Hz	
Exposure Time	8bits output	24 μ seconds to 20 seconds (Default: 24 μseconds)	
	10bits output		
	10bits Packed output		
Gain	Analog	N/A	
	Digital	x1 to x5 (Default: x1)	
ROI		Horizontal: 8 to 2,048 pixels / Vertical: 4 to 1,088 lines (Default: 2,048 x 1,088)	Horizontal: 8 to 2,048 pixels / Vertical: 4 to 2,048 lines (Default: 2,048 x 2,048)
		Adjustable steps for image size: 8 pixels in horizontal direction / 2 lines in vertical direction Adjustable steps for offset: 8 pixels in horizontal direction / 2 lines in vertical direction	
Multi ROIs		N/A	
Gamma		Gamma 1.0 (Factory default) or uploadable gamma table (Default: 1)	
HDR		Support	
Binning		Horizontal: 1/2, Vertical: 1/2 / Off	
Decimation		N/A	
Flip Image		N/A	
Pixel Blemish Correction		Up to 64 points	
Auto Image Control	Auto Exposure	Support	
	Auto Gain (AGC)	Support	
	Auto White Balance	N/A	
Operational Mode		Edge preset trigger / Pulse width trigger / Free run	
Communication		UART communication through Ethernet port	
Interface		IEEE802.3 (1000BASE-T)	
Protocol		GigE Vision 1.2 GenICam 2.0	
I/O		One opt-isolated input and two open collector outputs (+3.3 V)	
Power	Input Voltage	+10.8 to +26.4 Vdc (IO Connector) or Power Over Ethernet (IEEE802.3af compliance)	
	Consumption	Less than 3.6 W	

Default: **Bold**

4.2 Spectral Sensitivity Characteristics

4.2.1 STC-CMB2MPOE / STC-CMB4MPOE

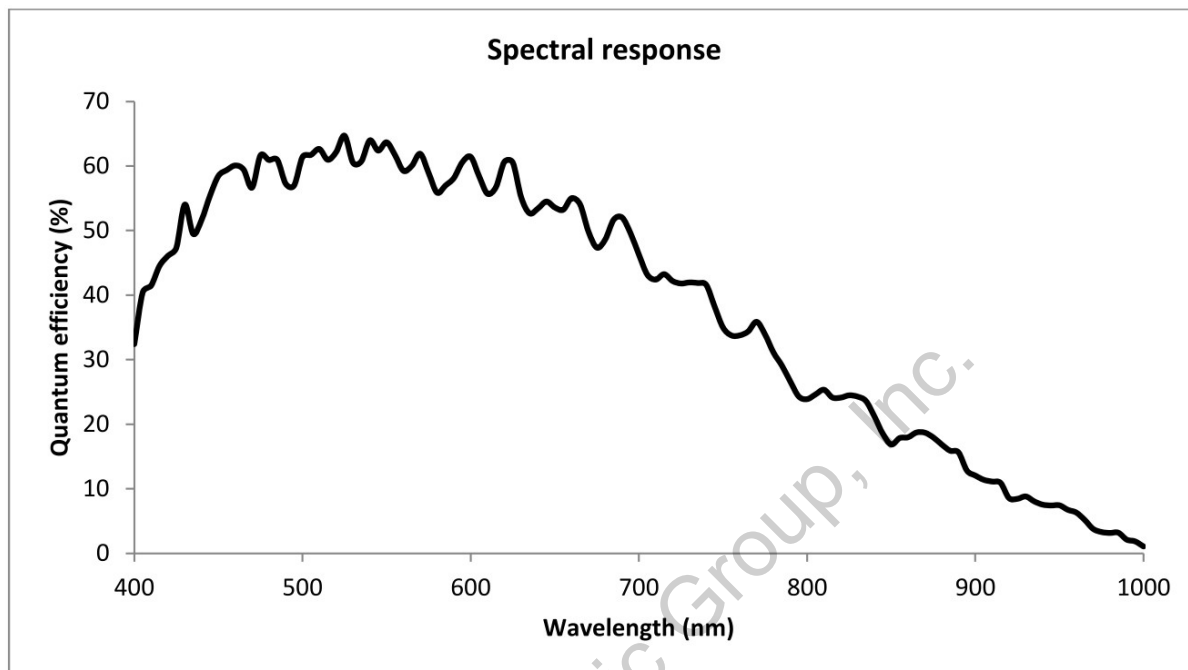

4.2.2 STC-CMC2MPOE / STC-CMC4MPOE

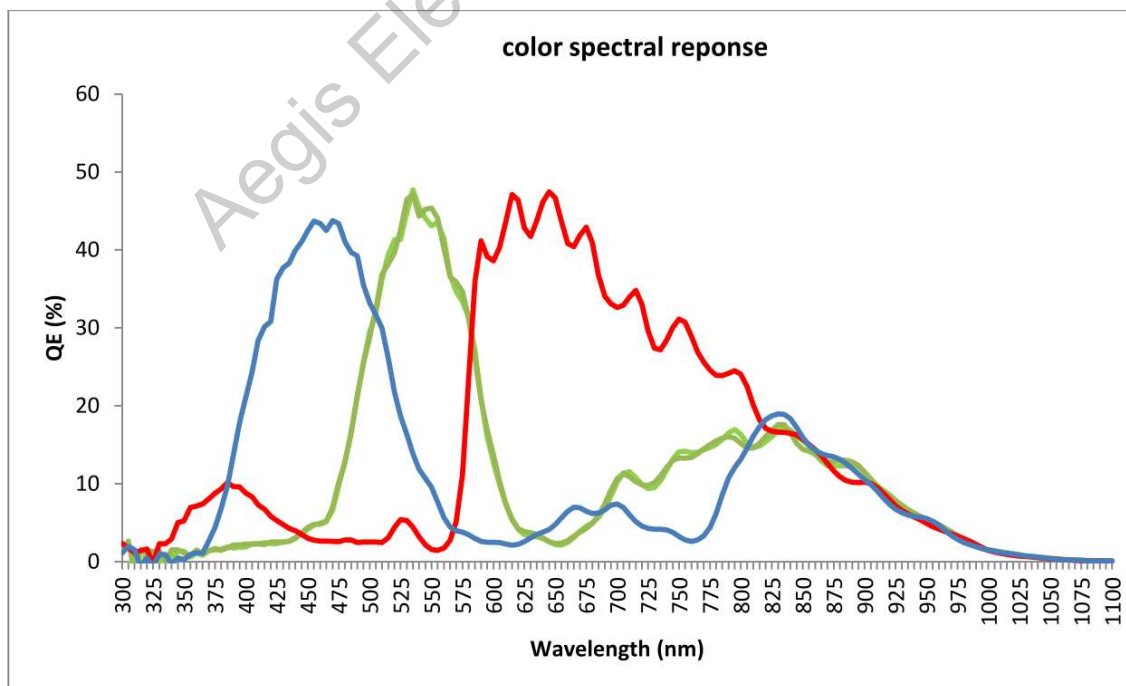

4.2.3 STC-CMB2MPOE-IR / STC-CMB4MPOE-IR (Near IR Model)

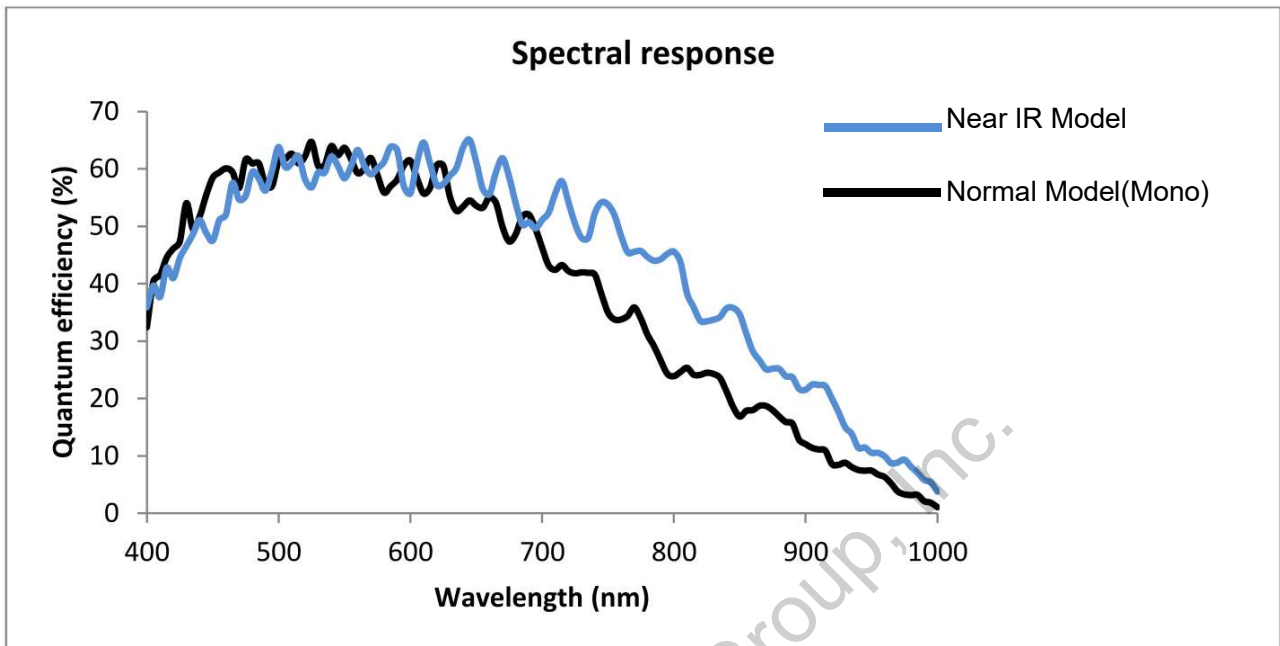

4.3 Mechanical Specifications

Model Number	STC-CMB2MPOE / STC-CMB4MPOE / STC-CMB2MPOE-IR / STC-CMB4MPOE-IR	STC-CMC2MPOE / STC-CMC4MPOE
Dimensions	35 (W) x 35 (H) x 55.9 (D) mm (*1)	
Optical Filter	No Optical Filter	No Optical Filter (*2)
Optical Center Accuracy	Positional accuracy in Horizontal and Vertical directions: +/- 0.3 mm Rotational accuracy of Horizontal and Vertical: +/- 2.0 deg.	
Material	Aluminum (AC)	
Lens Mount	C mount	
Connectors	RJ45 connector Power- I/O connector: HR10A-7R-6PB (Hirose) or equivalent	
Camera Mount Screws	Two 1/4" Tripod screw holes (One on top and bottom plate) Eight M4 screws holes (Four on top and bottom plate)	
Weight	Approximately 120 g	

(*1) Excluding connectors

(*2) The color model with IR Cut Filter is optional mode. Please contact to sale representative.

4.4 Environmental Specifications

Model Number	STC-CMB2MPOE / STC-CMB4MPOE / STC-CMB2MPOE-IR / STC-CMB4MPOE-IR	STC-CMC2MPOE / STC-CMC4MPOE
Operational Temperature / Humidity	Minimum	Environmental Temperature -5 deg. C, Environmental Humidity: 0 to 85 %RH (No condensation)
	Maximum (*1)	Camera housing temperature (top plate) shall not exceed +65 deg. C (This corresponds to an environmental temperature of approximately +40 deg. C)
Storage Temperature / Humidity	Environmental Temperature: -30 to +65 deg. C, Environmental Humidity: 0 to 85 %RH (No condensation)	
Vibration	20 Hz to 200 Hz to 20 Hz (5 min. / cycle), acceleration 10 G, XYZ 3 directions 30 min. each	
Shock	Acceleration 38 G, half amplitude 6 mseconds, XYZ 3 directions 3 times each	
Standard Compliancy	EMS: EN61000-6-2, EMI: EN55011	
RoHS	RoHS Compliance	

(*1) When the camera using under the condition that exceeds +40 deg. C environmental temperature, please insure the camera installs with the appropriate heat dissipation to keep the housing temperature less than +65 deg. C. If camera has a mounted lens and a tripod with an aluminum plate, this could decrease the camera housing temperature for heat dissipation.

Taking these steps will maintain the heat rating of the electronic components of the camera.

Upper side of camera

Measuring point

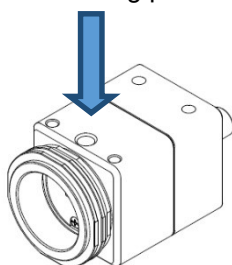

5 Connector Specifications

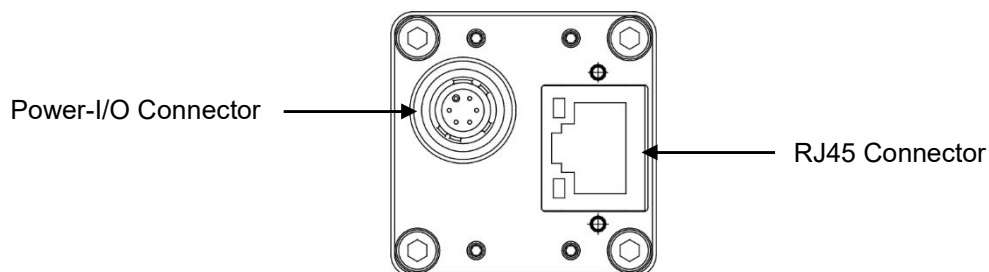

5.1 RJ45 Connector

This product is PoE compliant. Please supply power (+10.8 to +26.4 Vdc) through the power-I/O connector when using non-PoE-compliant NIC.

Pin Assignment

Pin No.	Signal Name
1	TA+
2	TA-
3	TB+
4	TC+
5	TC-
6	TB-
7	TD+
8	TD-

LED

Green LED	Yellow LED	Status
Green Light ON	Yellow Light ON	Power ON(1GB NIC)
Green Light OFF	Yellow Light OFF	Power ON(100MB NIC)
Green Light ON	Yellow Light Blinking	1Gb Transferring
Light OFF	Yellow Light Blinking	100 Mb Transferring

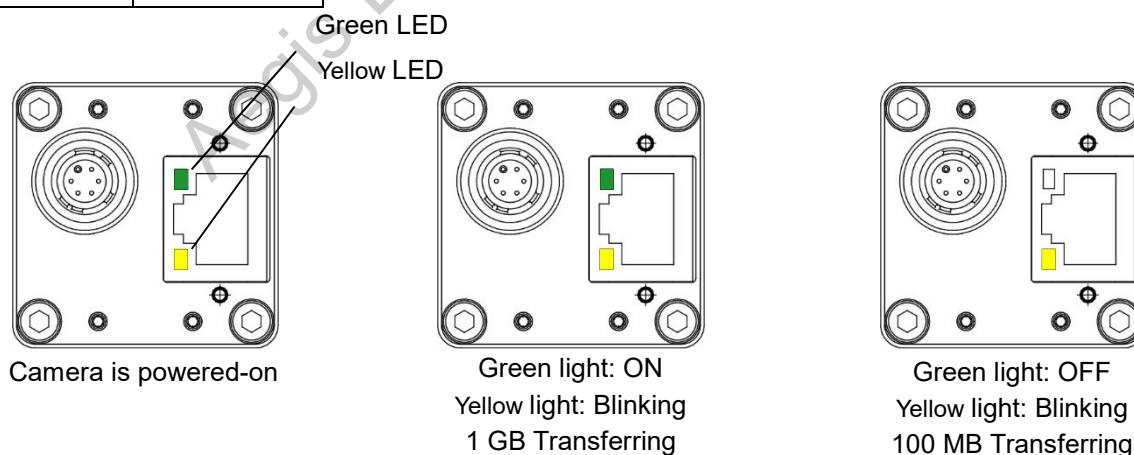

Please use a 1GB supported NIC, Network Switcher and LAN cable. Check that the NIC and Network Switcher being used is "1GB transferring".

5.2 Power and Control Signal Connector

HR10A-7R-6PB (Hirose) or equivalent

This connector is for the power supply (12Vdc) and input /output signals.

Use HR10A-7P-6S (Hirose) or equivalent for the cable side.

Pin assignment

Pin No.	Signal Name	IN / OUT	Voltage
1	GND	IN	0 V
2	I/O-1	OUT	+3.3 V Open Collector
3	I/O-2	OUT	+3.3 V Open Collector
4	TRG_In- (Opt. Isolated -)	IN	Low: Smaller than +1.0 V High: +3.0 to +26.4 V
5	TRG_In+ (Opt. Isolated +)	IN	* potential difference between TRG_In- and TRG_In+
6	POWER IN	IN	+10.8 to +26.4 Vdc

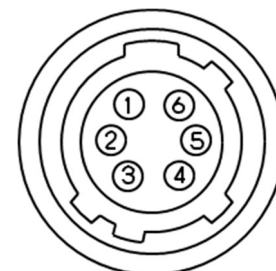

Configuration of I/O-1(Pin No.2) and I/O-2(Pin No.3)

Output pin can be assigned through register setting or GenICam Command.

GenICam command
I/O-1 (Pin No.2) / I/O-2 (Pin No.3)
1) FrameTriggerWait (initial setting for I/O-1)
2) UserOutput
3) ExposureActive (initial setting for I/O-2)
4) TriggerAuxiliary
5) TriggerInternal
6) SensorReadOut
7) StrobeSignal

1) FrameTriggerWait

The user can check the camera condition (camera exposure and image output processing by the trigger signal with this FrameTriggerWait signal).

This signal is LOW for the period from the trigger input signal to the image output.

2) UserOutput

The status of the UserOutput signal can change with the "UserOutputValue".

3) ExposureActive

The user can check the exposure time with the ExposureActive signal.

4) TriggerAuxiliary

The TriggerAuxiliary signal is the input trigger signal.

5) TriggerInternal

The TriggerInternal signal is the input trigger signal with the trigger delay time.

6) SensorReadOut

The SensorReadOut signal is the FVAL signal, which is the image output period of the time.

7) StrobeSignal

The StrobeSignal signal is the strobe control signal.

Aegis Electronic Group, Inc.

5.2.1 Equivalent Circuit for the Input Pin of the I/O Connector

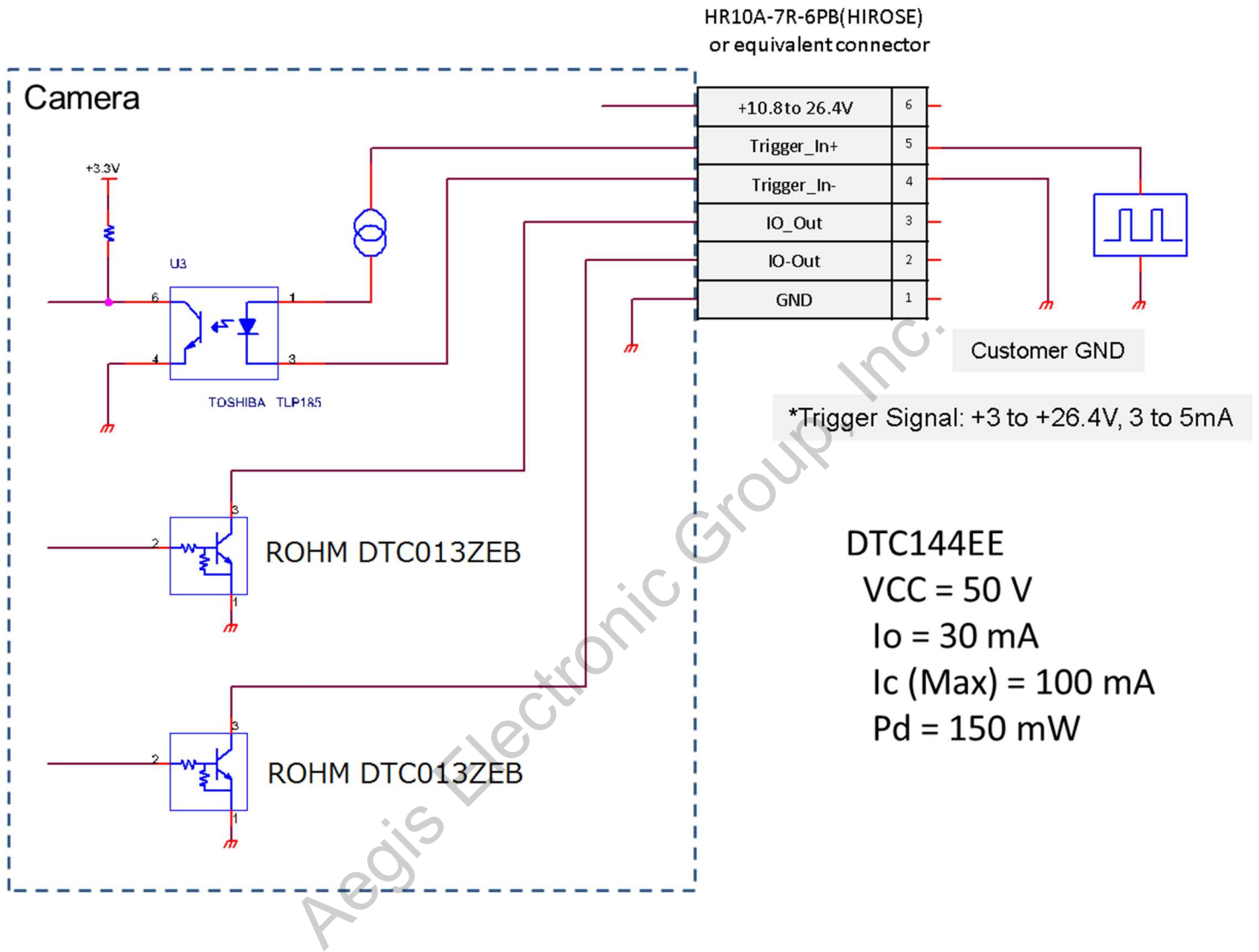

5.2.2 Typical Input Circuit

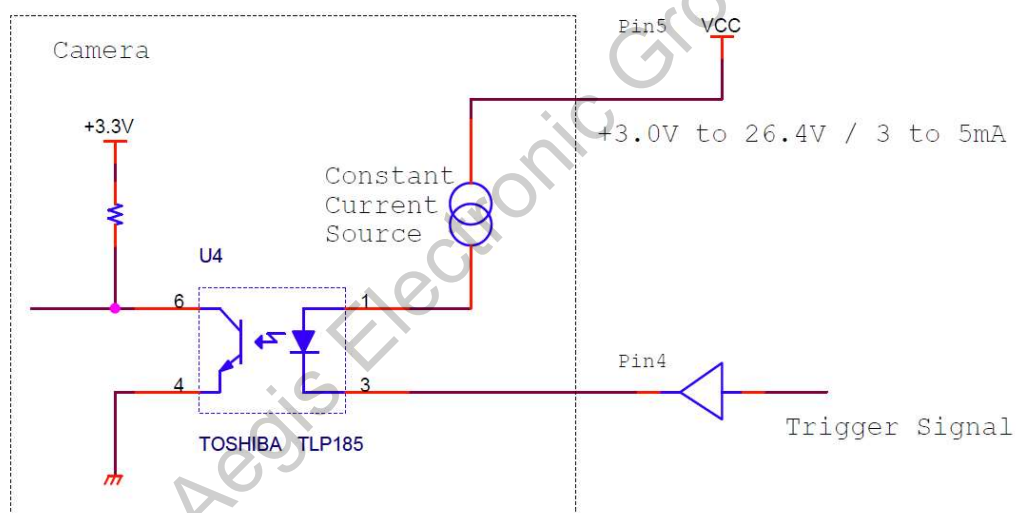
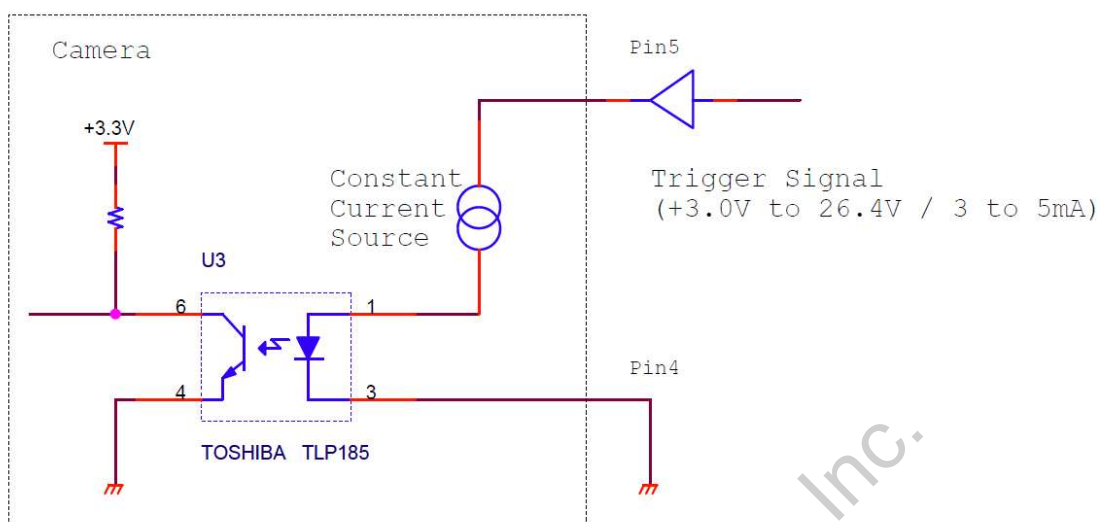

5.2.3 Typical Output Circuit

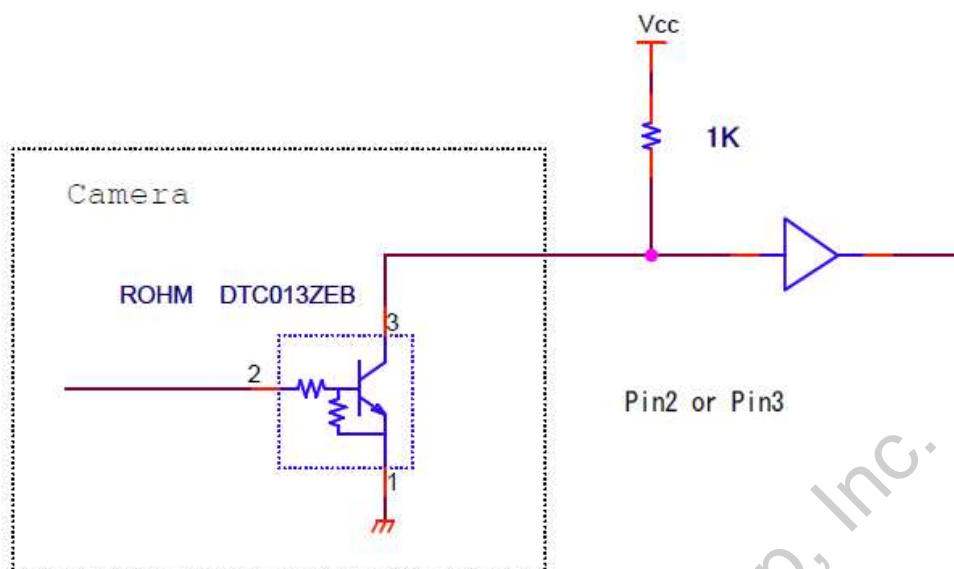

Note:
Value of Vcc and
Pull up register can be set
within the spec of
transistor.

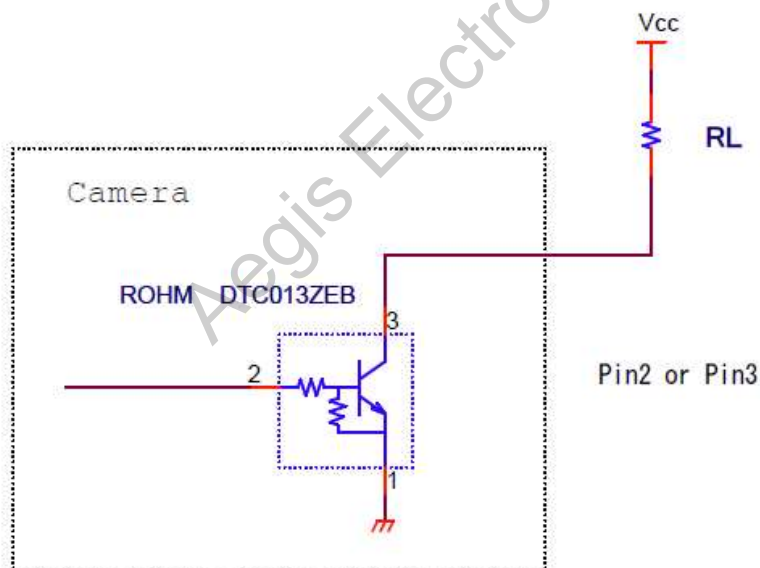

5.2.4 Input and Output Signal Timing (Hardware Trigger)
 Case of "External Hardware Trigger", "Positive Edge Trigger", "Edge Preset Exposure",

Camera internal processing

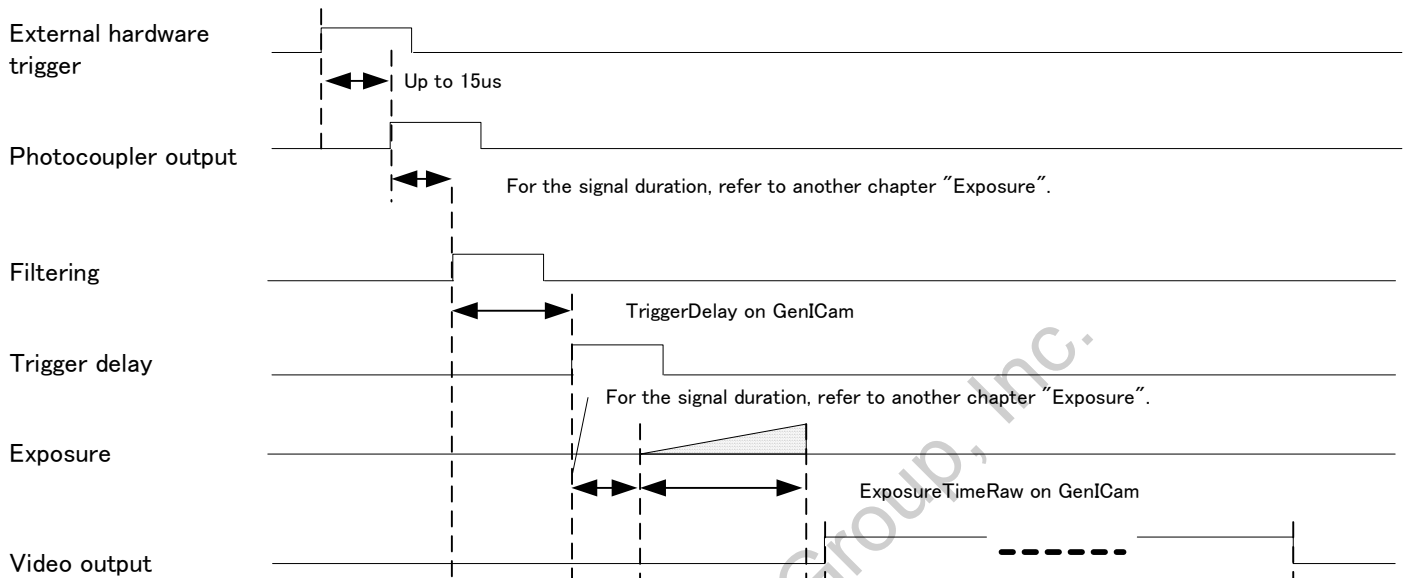

Output Signal

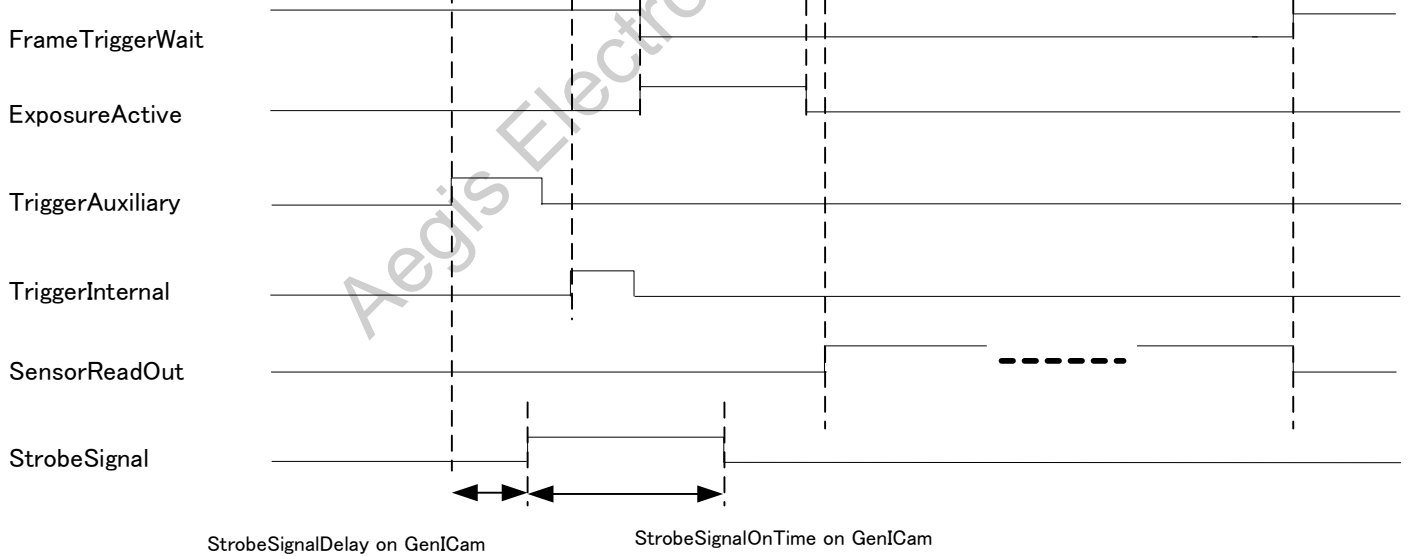

5.2.5 Input and Output Signal Timing (Software Trigger)
 Case of "Software Trigger", "Positive Edge Trigger", "Edge Preset Exposure",

Camera internal processing

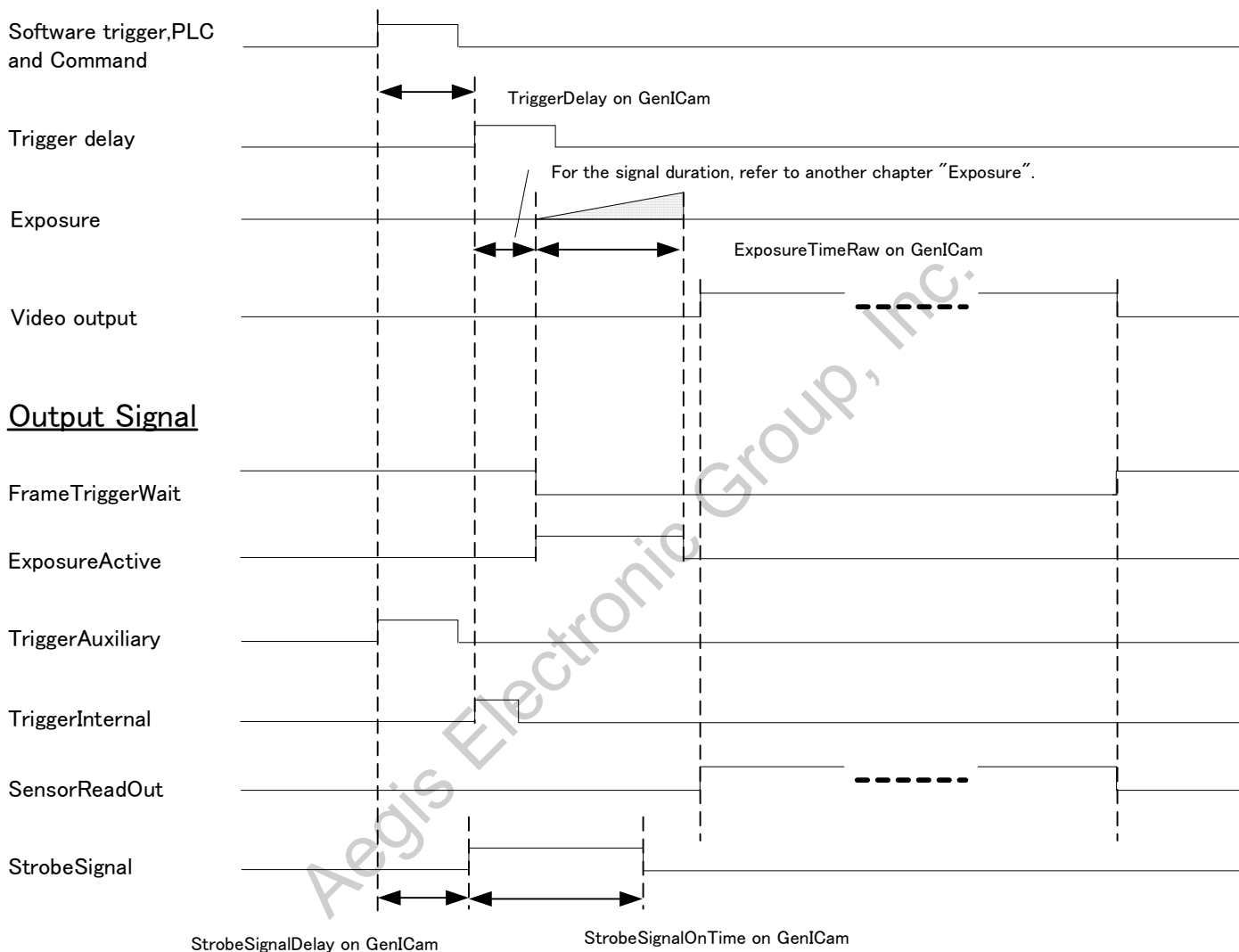

6 Dimensions

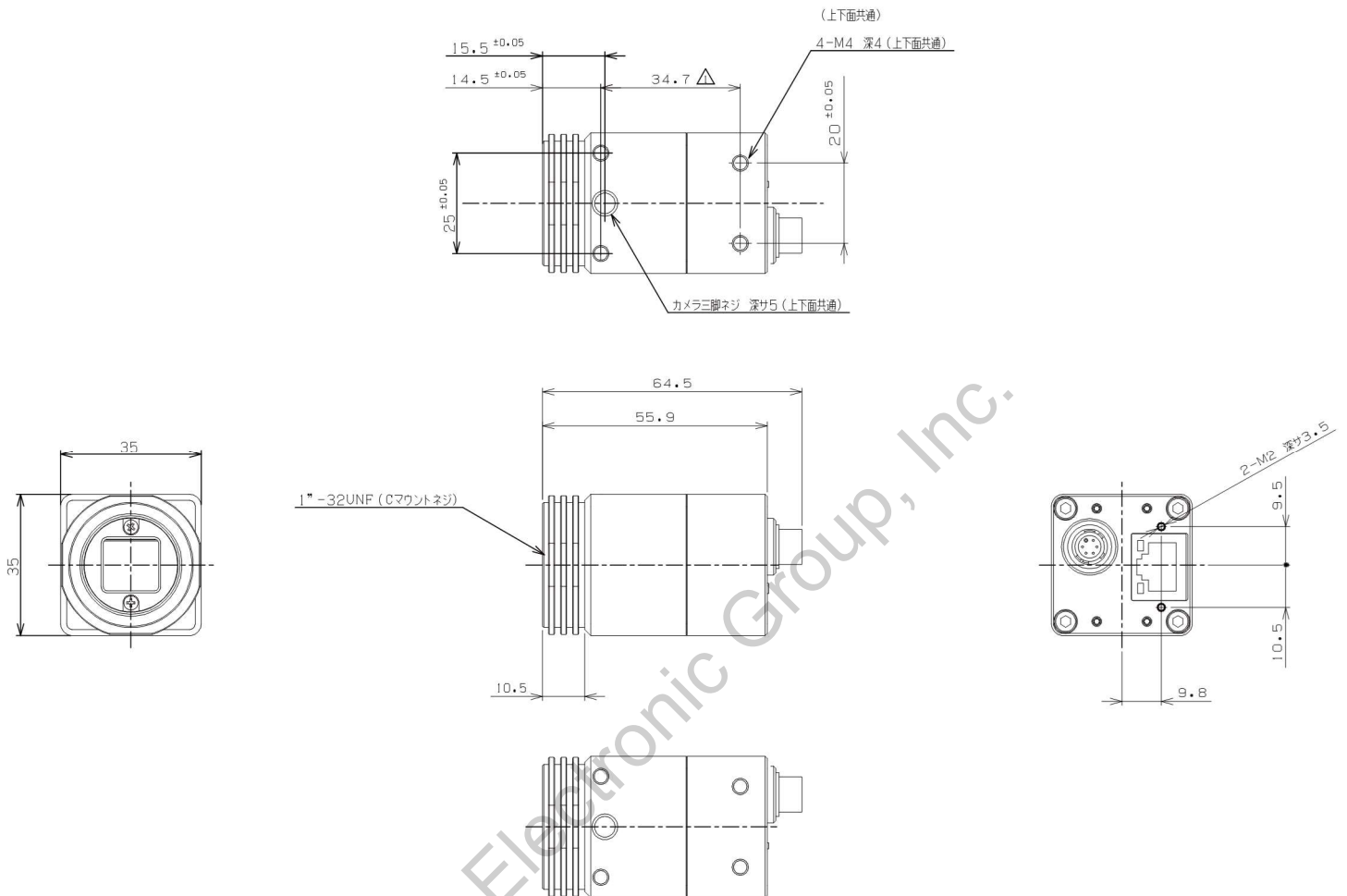

Unit:mm

7 Sensor information

7.1 Pixel Transferring Image

STC-CMB2MPOE / STC-CMC4MPOE (Monochrome)
STC-CMB2MPOE-IR / STC-CMB4MPOE-IR (Near IR)

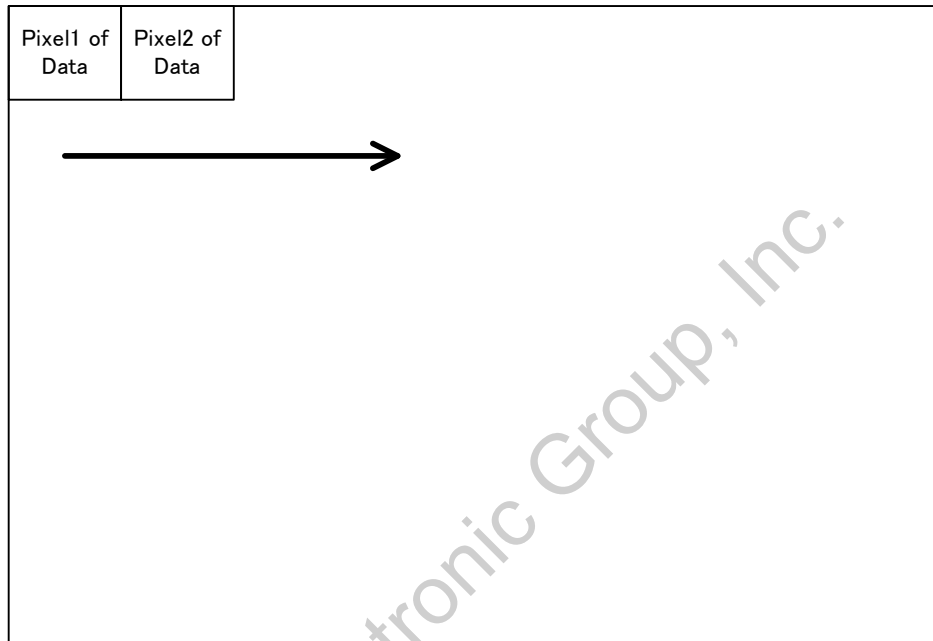

Pixel (n) of Data: nth pixel being transferred

STC-CMC2MPOE / STC-CMC4MPOE (Color)

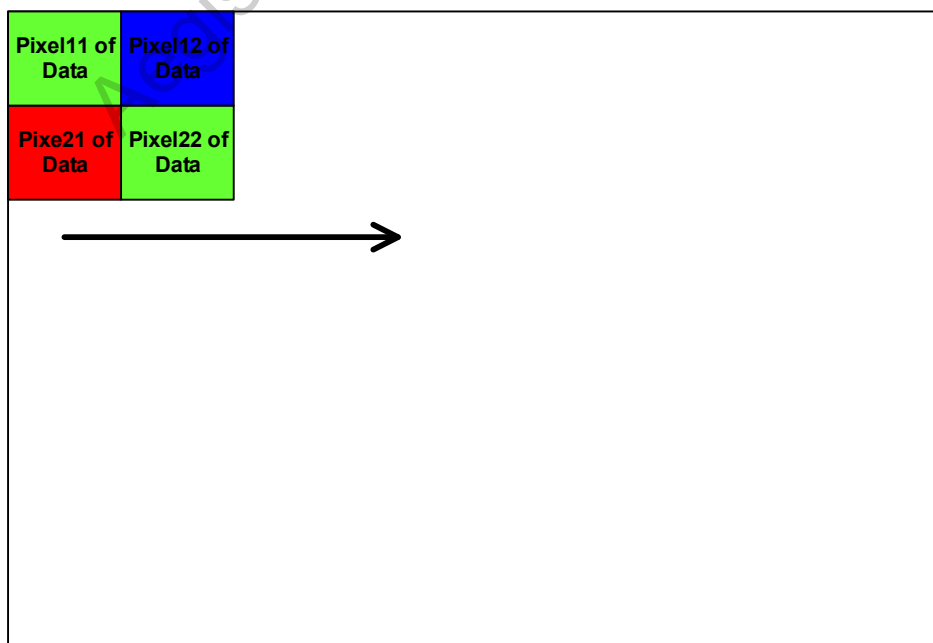

Pixel (m, n) of Data: nth pixel of the mth line being transferred

8 Camera Operational Modes

8.1 Normal Mode

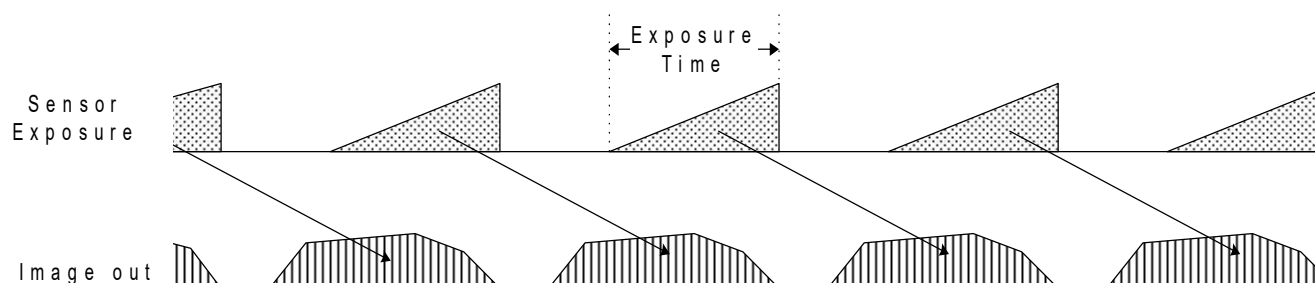

8.2 Pulse width trigger mode

In this trigger mode with positive polarity, the camera exposure starts at the rising edge of the trigger pulse and stops at the falling edge of the trigger pulse. Therefore, if positive polarity exposure is selected, the exposure periods are the high states of the trigger pulse.

8.2.1 Timing

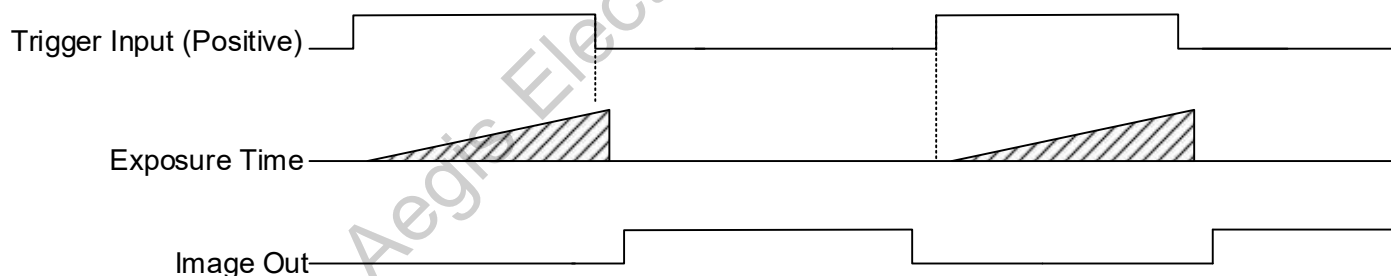

Note 1: The exposure time is set by active pulse duration of trigger signal.

8.2.2 Exposure Timing with the Positive Polarity Trigger Signal

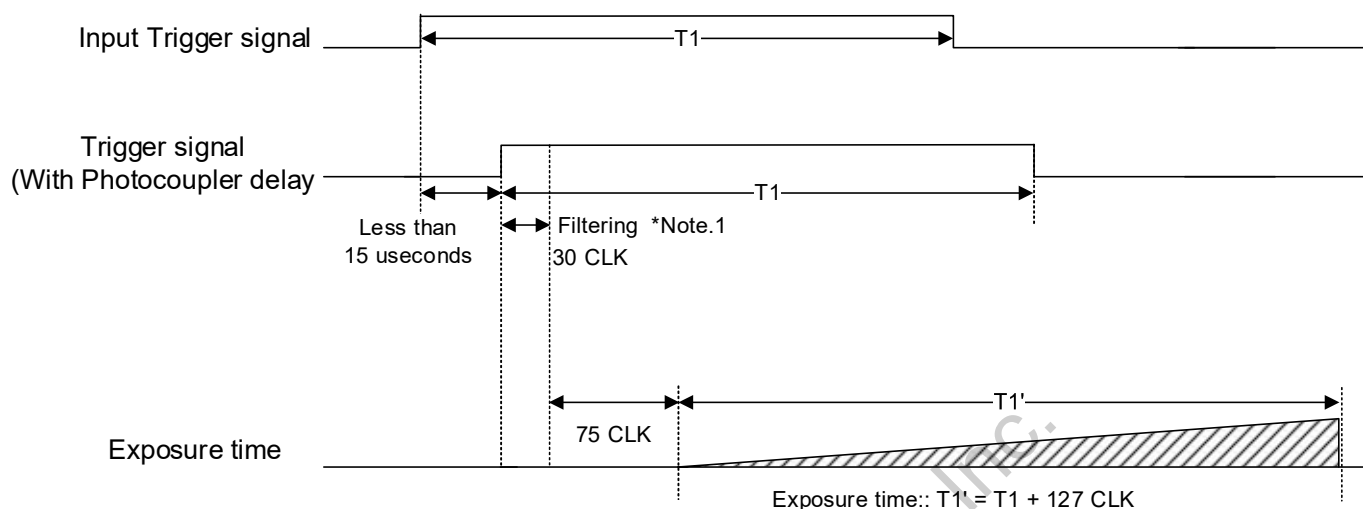

Note 1: The trigger signal will be removed by the filtering if the pulse width of the input trigger signal is less than 30 CLK. Please input a trigger signal with more than 31 CLK pulse width.

Note 2: The exposure will start 105 CLK after the rising edge of the trigger signal.

8.2.3 Exposure Timing with the Negative Polarity Trigger Signal

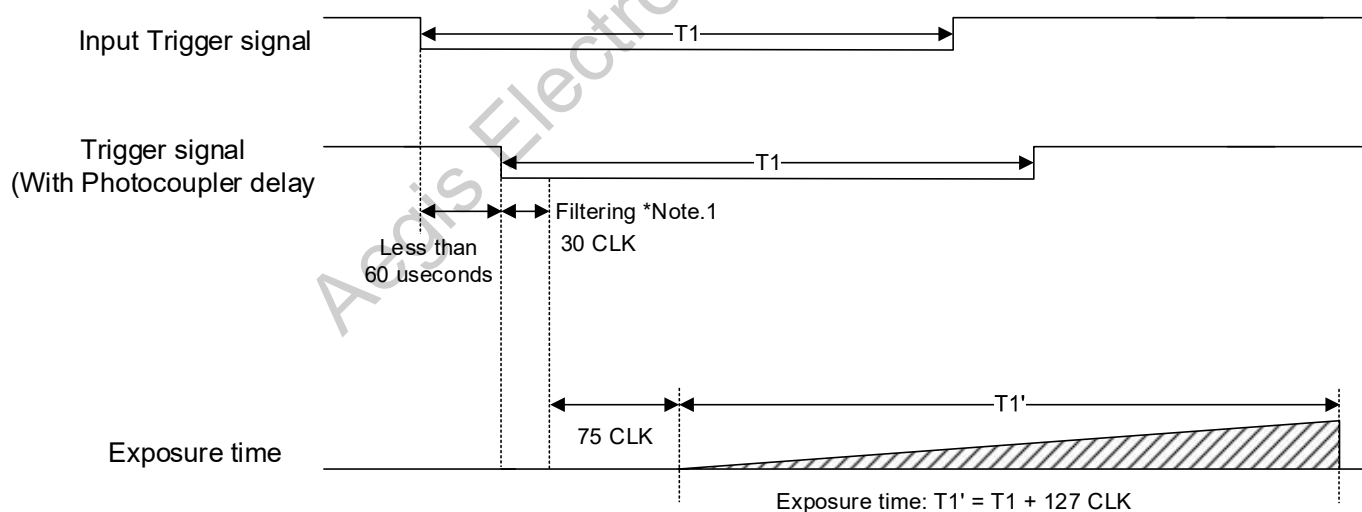

Note 1: The trigger signal will be removed by the filtering if the pulse width of the input trigger signal is less than 30 CLK. Please input a trigger signal with more than 31 CLK pulse width.

Note 2: The exposure will start 105 CLK after the rising edge of the trigger signal.

8.3 Edge Preset Trigger Mode

In this “edge preset trigger mode”, the camera exposure starts at the rising edge of the trigger signal like the “pulse width trigger mode” in the previous sections. However, in this mode, the exposure duration time is based on the preset value stored by the camera setting communication.

8.3.1 Timing

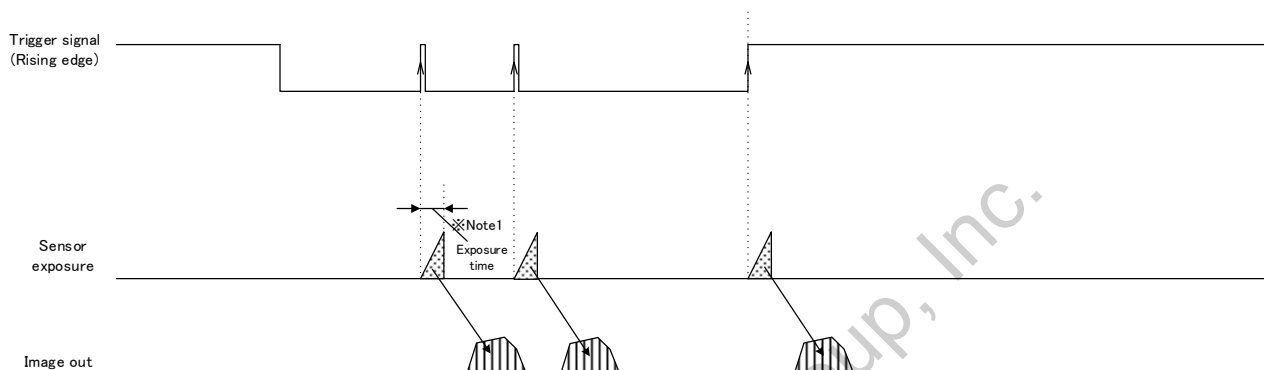

Note 1: The exposure time is set by preset electronic shutter speed.

8.3.2 Exposure Timing with the Positive Polarity Trigger Signal

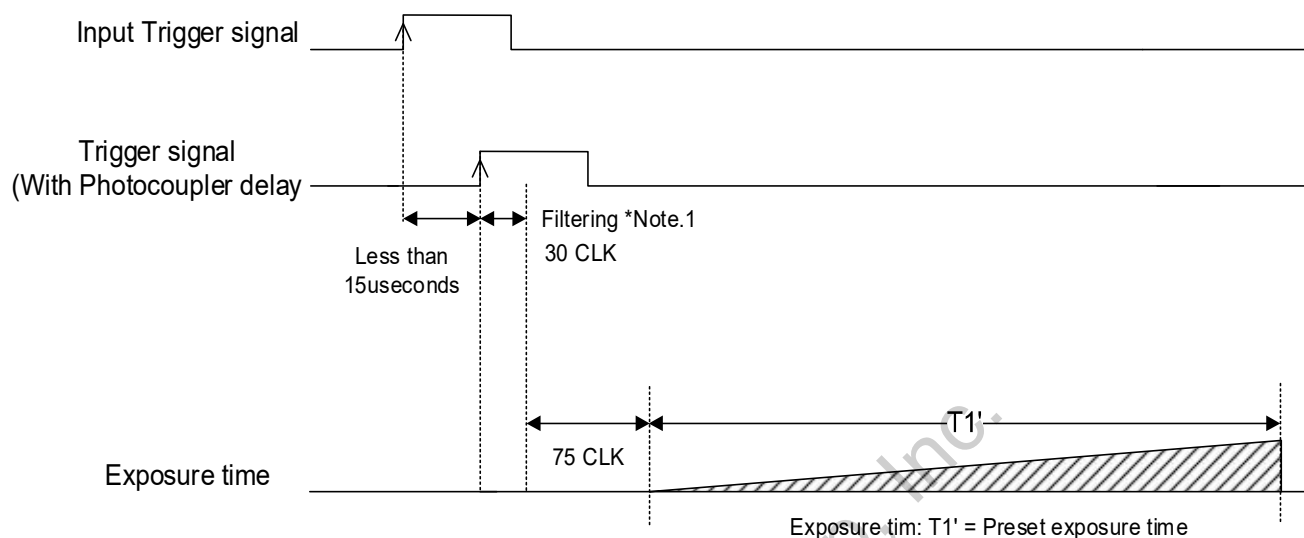

Note 1: The trigger signal will be removed by the filtering if the pulse width of the input trigger signal is less than 30 CLK. Please input a trigger signal with more than 31 CLK pulse width.

Note 2: The exposure will start 105 CLK after the rising edge of the trigger signal.

8.3.3 Exposure Timing with the Negative Polarity Trigger signal

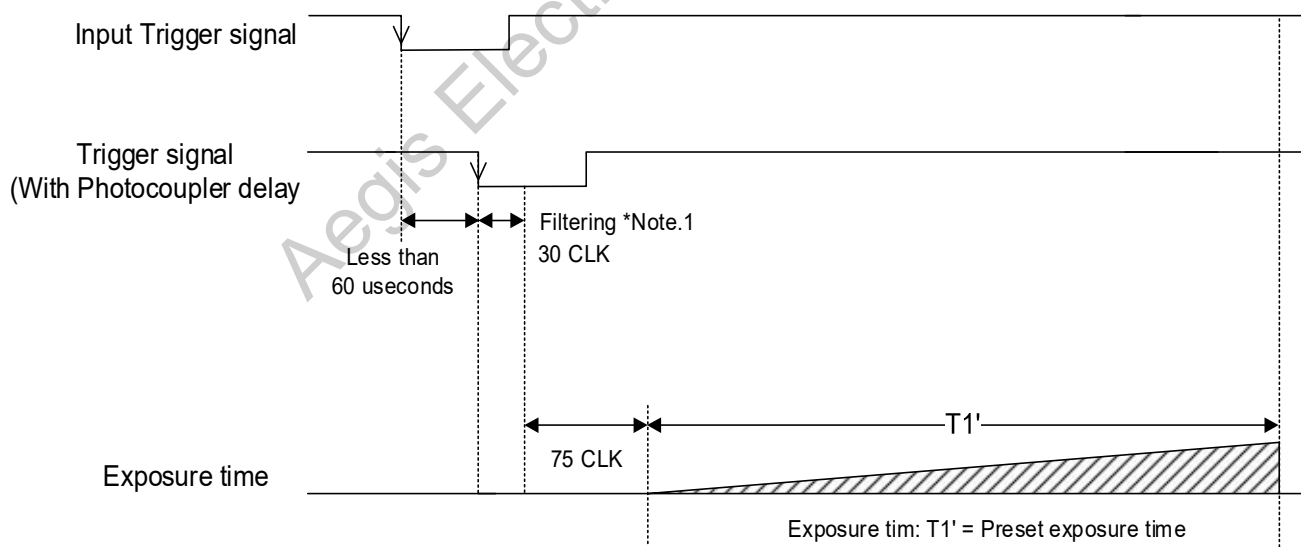

Note 1: The trigger signal will be removed by the filtering if the pulse width of the input trigger signal is less than 30 CLK. Please input a trigger signal with more than 31 CLK pulse width.

Note 2: The exposure will start 105 CLK after the rising edge of the trigger signal.

8.4 Edge Preset Trigger Mode (Trigger Input While the Image Is Out)

In this trigger mode, the camera exposure starts at the rising edge of the trigger pulse.

If trigger signal input is required while the image is out, then it is necessary to disable the trigger signal mask with the communication.

To avoid generating additional noise on the image, it is necessary to set the "H reset" at the exposure start mode.

8.4.1 Timing

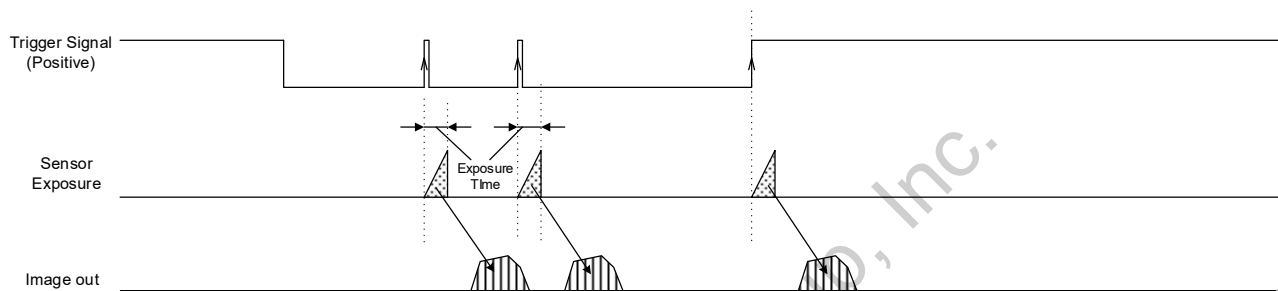

Note 1: The exposure time is set by the preset electronic shutter speed.

9 Camera Functions

9.1 ROI (Region of Interest)

The specified area of the image can output from the camera with ROI function.

The frame rate is increased when the height is reduced.

The frame rate does not increase when the width is reduced.

9.1.1 ROI (1 region)

GenlCamparamters

Width	Integer type	Width of the output image (pixels) (Width + OffsetX) should not exceeded maximum width.
Height	Integer type	Height of the output image (lines) (Height + OffsetY) should not exceeded maximum height.
OffsetX	Integer type	Horizontal (pixel) offset Default: 0, Adjustable steps: 8 pixels
OffsetY	Integer type	Vertical (line) offset Default: 0, Adjustable steps: 2 liens

The ROI area settings are below:

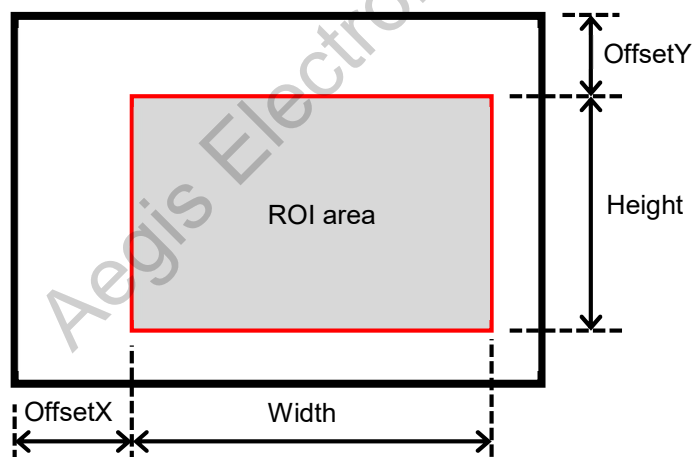

Width / Height setting range

		STC-CMB2MPOE STC-CMC2MPOE STC-CMB2MPOE-IR	STC-CMB4MPOE STC-CMC4MPOE STC-CMB4MPOE-IR
Width	Range	8 to 2,048 pixels	8 to 2,048 pixels
	Default	2,048	2,048
	Adjustment steps	8 pixels	8 pixels
Height	Range	4 to 1,088 lines	4 to 2,048 lines
	Default	1,088 lines	2,048 lines
	Adjustment steps	2 lines	2 lines

Aegis Electronic Group, Inc.

9.2 Pixel Format

The image format from camera can be set on the Pixel Format.

GenICam Parameters

PixelFormat	IEnumeration Type	Pixel Format
-------------	-------------------	--------------

The following chart shows the available Pixel Formats on the camera:

Output Bit	Pixel Format	
	Monochrome Camera	Color Camera
8bits	Mono8	BayerRG8
10bits	Mono10	BayerRG10
10bits Packed	Mono10Packed	BayerRG10Packed

Each format specified on GenICam PFNC (Pixel Format Naming Convention).

9.3 Binning

Binning is add and average beside pixels into one pixel.

The pixel data inside of red square add or average as one pixel.

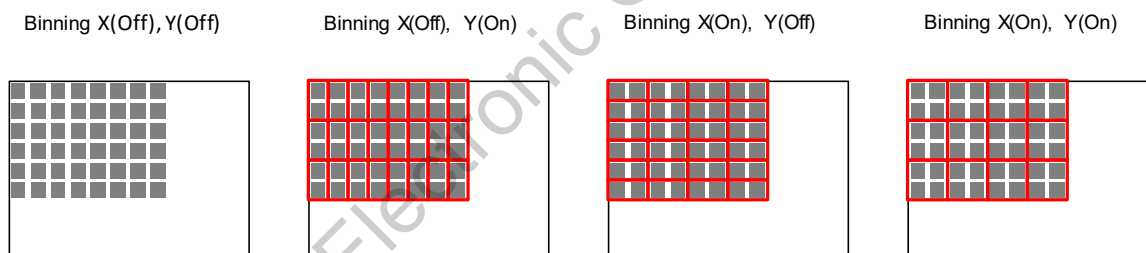

GenICamParameters

BinningHorizontal	Integer Type	Sets Binning on Horizontal direction 1: Disable Binning 2: Binning 2 Pixel
BinningVertical	Integer Type	Sets Binning on Vertical direction 1: Disable Binning 2: Binning 2 Pixel

9.4 Gain

The analog gain and the digital gain are available for the gain control.

9.4.1 Digital gain

This parameter sets the digital gain.

GenICam parameter

DigitalGain	Integer type	Digital gain. Range: 0 to 511, Default: 0
-------------	--------------	--

Digital gain formula

Gain (xtimes) = 1+ (DigitalGain / 64)

9.5 Black level

This parameter sets the black level (the clamp level for the black signal).
The bottom of the signal is clamped at this setting level. The signal does not become below this level.

GenICam parameter

BlackLevel	Float type	Black level. Range: 0 to 31, Default: 10
------------	------------	---

Black level formula

At 10bits output: Black level (grayscale) = BlackLevel

At 8bits output: Black level (grayscale) = BlackLevel / 4

9.6 ALC (Auto Light Control)

ALC function has two control methods, which is AGC (Auto Gain Control) and the auto shutter. The AGC and the auto shutter sets up individually.

The camera parameters are adjusted to the brightness of the image is maintained with the target brightness automatically with the ALC function.

GenICam parameters (for AGC and auto shutter)

TargetBrightness	Integer type	Target brightness. Range: 0 to 255, Default: 128	
ACL_Peak_Average	Integertype	Importance ratio for the brightness peak at ALC control. Range: 0 to 255, Default: 0	
ALCWeight1 ALCWeight2 ALCWeight3 ALCWeight4 ALCWeight5 ALCWeight6 ALCWeight7 ALCWeight8 ALCWeight9	Integer type	Weight. Range: 0 to 15, Default: 1 * Set 10 on ALCWeight5 only Sets the weight for each weight area.	
ALCWindowV1 ALCWindowV2 ALCWindowV3 ALCWindowV4	Integer type	Vertical positions for the frame of the weight area.	
		STC-CMB2MPOE	STC-CMB4MPOE
		STC-CMC2MPOE	STC-CMC4MPOE
		STC-CMB2MPOE-IR	STC-CMB4MPOE-IR
	Range	0 to 1,087	0 to 2,047
	Default	V1 (32), V2 (394), V3 (694), V4 (1,056)	V1 (32), V2 (714), V3 (1,334), V4 (2,016)
ALCWindowH1 ALCWindowH2 ALCWindowH3 ALCWindowH4	Integer type	Horizontal positions for the frame of the weight area.	
		STC-CMB2MPOE	STC-CMB4MPOE
		STC-CMC2MPOE	STC-CMC4MPOE
		STC-CMB2MPOE-IR	STC-CMB4MPOE-IR
	Range	0 to 2,047	0 to 2,047
	Default	H1 (32), H2 (718), H3 (1,330), H4 (2,012)	H1 (32), H2 (718), H3 (1,330), H4 (2,012)

Target brightness (TargetBrightness) formula

At 10bits output: Target brightness (grayscale) = TargetBrightness x 4

At 8bits output: Target brightness (grayscale) = TargetBrightness

About the importance ratio for the brightens peak at ALC control (ACL Peak Average)

When 0 sets, Average: 100 %, Peak: 0 %. The ALC control with the brightness average.

When 255 sets, Average: 0 %, Peak: 100 %. The ALC control with the brightness peak.

When 128 sets, Average: 50 %, Peak: 50 %.

9.6.1 ALC control method

The ALC control with the weight area1 to 9.

The weight area setting parameters are in below:

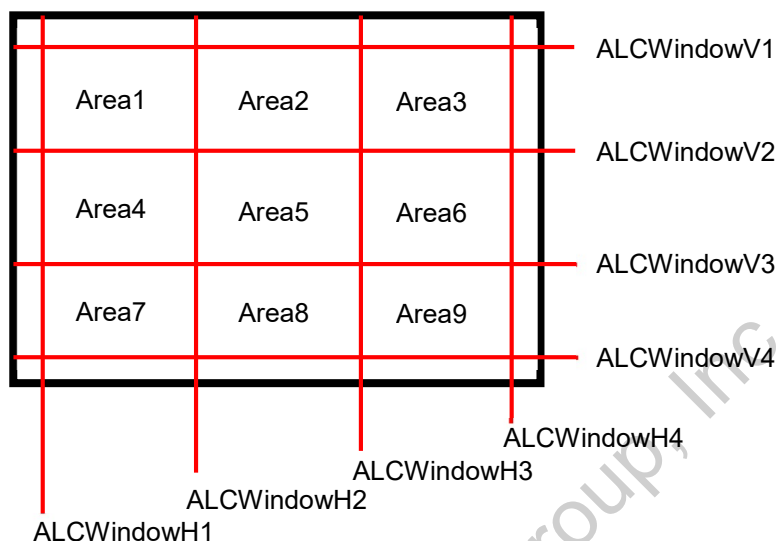

The brightness average and peak calculate for each weight area.

The target brightness comparison value calculates with “ALC_Peak_Average”, the brightness average and peak then compare with the target brightness to define the necessary brightness control (to dark or to bright).

The brightness of the image maintains to the “TargetBrightness” with the AGC and the auto shutter functions.

If AGC and the auto shutter are ON for the ALC control, the auto shutter function maintains the brightness first. The AGC function maintains the brightness if the brightness cannot maintain to the TargetBrightness with the auto shutter.

9.6.2 AGC (Auto Gain Control)

The brightness of the image maintains to the target brightness with the gain automatically.

If the brightness of the image is the darker than the target brightness, the gain increases up to AGCRange.

If the brightness of the image is the brighter than the target brightness, the gain decreases.

GenICam parameters

GainAuto	Enumeration type	AGC ON / OFF selection Selection: ON (Continuous) or OFF (Off). Default: OFF
AGCRange	Integer type	Maximum gain. Range: 0 to 255, Default: 255 This is the maximum gain for AGC.

9.6.3 Auto shutter

The brightness of the image maintains to the target brightness with the shutter automatically.

If the brightness of the image is the darker than the target brightness, the exposure time extends up to

Max_ShutterTime.

If the brightness of the image is the brighter than the target brightness, the exposure time becomes shorter up to

Min_ShutterTime.

GenICam parameters

ExposureAuto	Enumeration type	Auto shutter ON / OFF selection ON (Continuous), OFF (Off). Default: OFF
Min_ShutterTime	Integer type	Minimum exposure time (μsecond). Range: 10 to 16,777,215 Default: 10
Max_ShutterTime	Integer type	Maximum exposure time (μsecond). Range: 10 to 16,777,215 Default: 19094

9.6.4 ALC settings procedure

ALC settings procedure

1. Sets ALCWeight1 to 9.
2. Sets ALCWindowV1 to 4.
3. Sets ALCWindowH1 to 4.
4. Sets TargetBrightness.
5. Sets ACL_Peak_Average.
6. Sets AGCRange if AGC is using.
7. Sets Min_ShutterTime, if the auto shutter is using.
8. Sets Max_ShutterTime, if the auto shutter is using.
9. Sets "Continuous" at GainAuto, if AGC is using.
10. Sets "Continuous" at ExposureAuto, if the auto shutter is using.

9.7 White balance (Only available for the color cameras)

The color compensates with the gain adjustment each color.

The gain for each color has to adjust with the flat white target to each color has the same brightness.

The white balance control methods are the listed in the below:

OFF

Auto white balance

Push to set white balance

Preset1 to 3

9.7.1 White balance control methods

GenICam parameters

BalanceWhiteAuto	Enumeration type	White balance control method selection. Default: off
BalanceRatioSelector	Enumeration type	White balance control target color selection.
BalanceRatio	Float type	Color gain setting for the color selects at BalanceRatioSelector
YThreshold	Integer type	The brightness threshold to use the pixel for the auto white balance control. Default: 0, Range: 0 to 4,095
BalanceRatio_R_Once	Integer type	R white balance gain for OFF and push to set white balance. Default: 0
BalanceRatio_Gr_Once	Integer type	GR white balance gain for OFF and push to set white balance. Default: 0
BalanceRatio_B_Once	Integer type	R white balance gain for OFF and push to set white balance. Default: 0
BalanceRatio_Gb_Once	Integer type	Gb white balance gain for OFF and push to set white balance. Default: 0
BalanceRatio_R_Preset1	Integer type	R white balance gain for preset1. Default: 0
BalanceRatio_Gr_Preset1	Integer type	Gr white balance gain for preset1. Default: 0
BalanceRatio_B_Preset1	Integer type	B white balance gain for preset1. Default: 0
BalanceRatio_Gb_Preset1	Integer type	Gb white balance gain for preset1. Default: 0
BalanceRatio_R_Preset2	Integer type	R white balance gain for preset2. Default: 0
BalanceRatio_Gr_Preset2	Integer type	Gr white balance gain for preset2. Default: 0
BalanceRatio_B_Preset2	Integer type	B white balance gain for preset2. Default: 0
BalanceRatio_Gb_Preset2	Integer type	Gr white balance gain for preset2. Default: 0

GenICam parameters

BalanceRatio_R_Preset3	Integer type	R white balance gain for preset3. Default: 0
BalanceRatio_Gr_Preset3	Integer type	Gr white balance gain for preset3. Default: 0
BalanceRatio_B_Preset3	Integer type	B white balance gain for preset3. Default: 0
BalanceRatio_Gb_Preset3	Integer type	Gb white balance gain for preset3. Default: 0

9.7.2 OFF

The white balance with BalanceRatio_X_Once (X: R, Gr, B or Gb)

If the white balance process is not necessary, please sets 0 for BalanceRatio_X_Once (X: R, Gr, B or Gb)

White balance "OFF" setting procedure

1. Sets Off at BalanceWhiteAuto.

9.7.3 Auto white balance

The optimized white balance gain calculates each frame for the auto white balance.

Auto white balance setting procedure

1. Sets Continuous at BalanceWhiteAuto.

9.7.4 Push to set white balance

The white balance gain adjusts once after select this white balance then set to Balance_X_Once (X: R, Gr, B or Gb)

Sets OFF at BalanceWhiteAuto automatically after set Balance_X_Once.

Push to set white balance setting procedure

1. Sets the flat white target.
2. Sets Once at BalanceWhiteAuto.

9.7.5 Preset white balance1 to 3

The camera has three preset manual white balance.

Presets saving area

Preset1: BalanceRatio_R_Preset1,BalanceRatio_Gr_Preset1,
BalanceRatio_B_Preset1,BalanceRatio_Gb_Preset1

Preset2: BalanceRatio_R_Preset2,BalanceRatio_Gr_Preset2,
BalanceRatio_B_Preset2,BalanceRatio_Gb_Preset2

Preset3: BalanceRatio_R_Preset3,BalanceRatio_Gr_Preset3,
BalanceRatio_B_Preset3,BalanceRatio_Gb_Preset3

Preset white balance setting procedure

1. Sets the white balance gain for the preset1, 2 or 3. (X: 1 to 3)
(BalanceRatio_R_PresetX, BalanceRatio_Gr_PresetX,BalanceRatio_B_PresetX,BalanceRatio_Gb_PresetX)
2. Sets PresetX (X: 1 to 3) at BalanceWhiteAuto.

Aegis Electronic Group, Inc.

9.7.6 White balance calculate area setting

The white balance gain calculation area is changeable.

GenICam parameters

WB_WindowMode	Enumeration type	White balance gain calculation area selection Full screen (Off), Specified area (On). Default: Full screen	
WB_WindowV1 WB_WindowV2	Integer type	Vertical frame position for the specified area.	
		STC-CMC2MPOE	STC-CMC4MPOE
範圍		0 to 1,087	0 to 2,047
初期値	V1 (0), V2 (1,087)	V1 (0), V2 (2,047)	
WB_WindowH1 WB_WindowH2	Integer type	Horizontal frame position for the specified area.	
		STC-CMC2MPOE	STC-CMC4MPOE
範圍		0 to 2,047	0 to 2,047
初期値	H1 (0), H2 (2,047)	H1 (0), H2 (2,047)	

The brightness threshold for the white balance gain calculate pixel (YThreshold)

Threshold (grayscale) = YThreshold

12bits process in the camera.

The white balance calculation area settings are below:

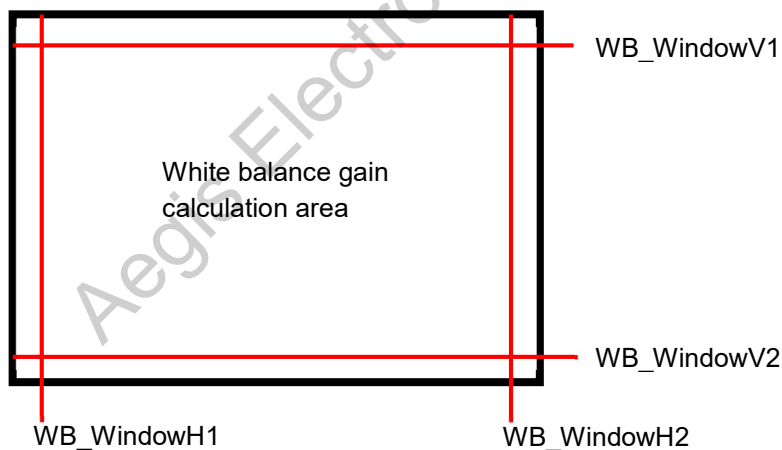

9.8 Gamma correction

The gamma correction is the gamma = 1.0 or the gamma table control.

GenICam parameters

GammaMode	Enumeration type	Gamma correction selection Gamma = 1.0 (Off), Gamm table control (On). Default: Gamma = 1.0
ReloadGammaData	Command type	Gamma table loading from ROM to RAM

Gamma table loading procedure (ReloadGammaData)

1. Executes ReloadGammaData.

9.8.1 Gamma table writing

It is necessary to use the virtual com port communication (eBUS SDK: PvSerialPort class) to write the gamma table to the camera. The gamma table cannot write the camera with GenICam parameter.

Please refer the other document for the details of the gamma table writing.

Aegis Electronic Group, Inc.

9.9 Save and load the camera setting data

The camera has the camera setting including the factory default, load function.
The camera has below two camera settings.

Default: The factory default settings (This setting cannot change)

User Set X: Over writeable camera settings (X: 0 to 7)

These camera settings load from ROM to the register in the RAM on the camera and camera settings save to ROM. The camera settings saving and loading is controllable with Parameters (User Set Selector, User Set Default), and commands (UserSetLoad, UserSetSave) in UserSetControl category of GenICam.

The details of the parameters and the functions are in the table below:

GenICam Parameters

UserSetSelector	IEnumeration Type	Select "Default" or "UserSetX" UserSetLoad or UserSetSave process for the selected settings.
UserSetLoad	ICommand Type	The camera settings load from ROM to the register in RAM.
UserSetSave	ICommand Type	The camera settings at the register in RAM save to ROM.
UserSetDefault	IEnumeration Type	Select which settings ("Default or UserSet X) load automatically when the camera power is on. This selection saves automatically.

9.9.1 Saving the Camera Settings

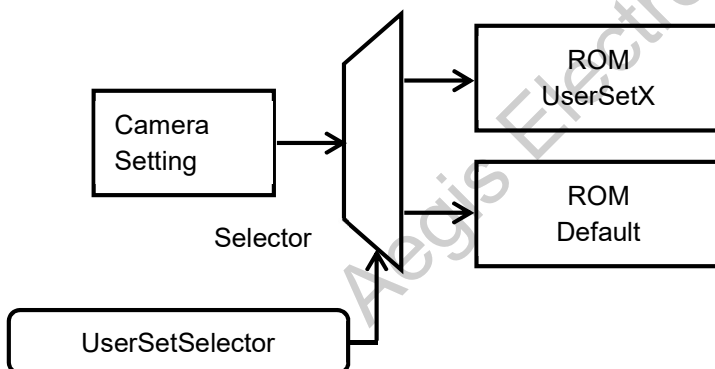

When UserSetSave is executing, the camera settings at the register in RAM are saved to the ROM that is selected at UserSetSelector.

Caution:
UserSetSave cannot execute when "Default" was selected at "UserSet Selector"

Setting Procedure

1. Selects "UserSetX" at "UserSetSelector"
2. Execute "UserSetSave"

9.9.2 Loading Camera Settings

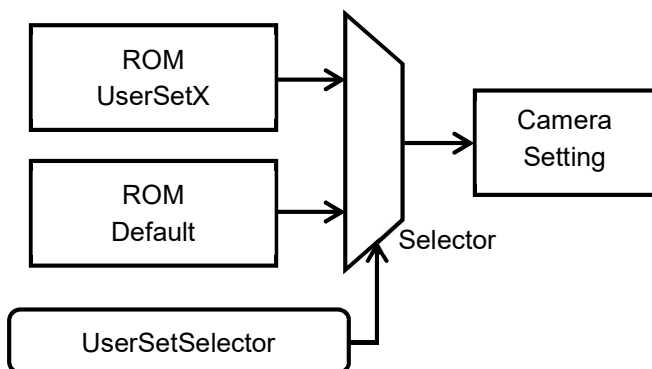

When UserSetLoad is executing, the camera settings load from the selected ROM that was selected at “UserSetSelector” to the register at RAM.

Setting Procedure

1. Select “UserSetX” (or Default) at “UserSetSelector”
2. Execute “UserSetLoad”

9.9.3 Loading Camera Settings when the Camera Power is on

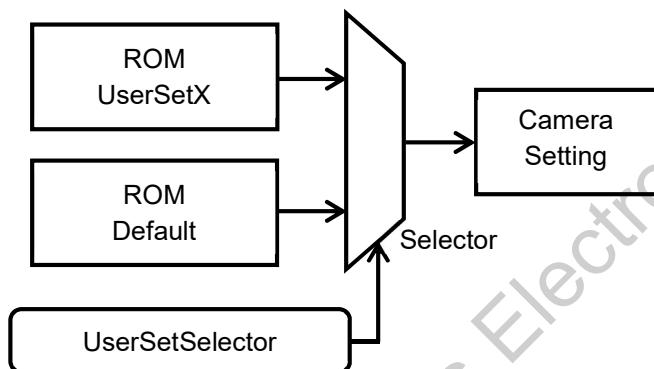

When the camera power is on, the camera settings load from the selected ROM that was selected at “UserSetDefault” to the register at RAM.

Setting Procedure

1. Set “UserSetX” or “Default” at “UserSetDefault”

9.9.4 Camera Settings Initialization

Please follow the below procedure for the camera settings put back to the factory default settings.

Setting Procedure

1. Selects “Default” at “UserSetSelector”.
2. Executes “UserSetLoad”.
3. Select “UserSet1” at “UserSetSelector”.
4. Executes “UserSetSave”.

9.10 Trigger

The description of trigger type and characteristic, please refer to the chapter “Image acquisition and Camera Mode”.

9.10.1 Trigger Signal Processing Process

External Hardware Trigger or Software Trigger input the camera’s internal process as follows.

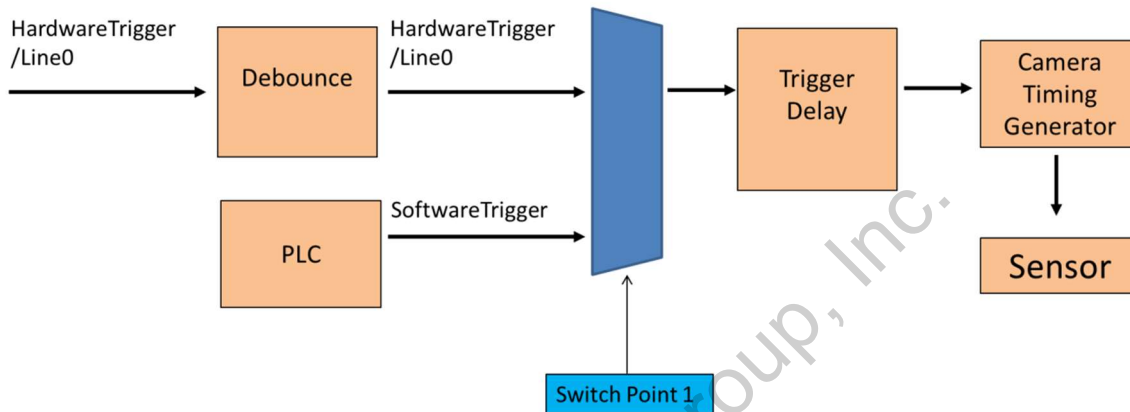

Switching Trigger can be done through register access or GenICam commands

Switching point 1: Switch to Hardware Trigger and Software Trigger

- TriggerSource = Software on GenICam
- TriggerSource = Hardware on GenICam
- TriggerSource = Line0 on GenICam

9.11 The camera settings (GenICam parameters) control with SDK

GenICam parameters are controllable with the eBUS SDK.
Please refer eBUS SDK API help file for the details.

9.11.1 Integer type parameter control

Integer type parameter such as "Width" control.

e.g. Width writing

```
[C++]    PvDevice.GetGenParameters()->SetIntegerValue("Width", 256);
[C#]     PvDevice.GenParameters.SetIntegerValue("Width", 256);
```

e.g. Width reading

```
[C++]    PvDevice.GetGenParameters()->GetIntegerValue("Width", &intValue);
[C#]     intValue = PvDevice.GenParameters.GetIntegerValue("Width");
```

9.11.2 Float type parameter control

Float type parameter such as "AcquisitionFrameRate" control.

e.g. AcquisitionFrameRate writing

```
[C++]    PvDevice.GetGenParameters()->SetFloatValue("AcquisitionFrameRate", 33.3);
[C#]     PvDevice.GenParameters.SetFloatValue("AcquisitionFrameRate", 33.3);
```

e.g. AcquisitionFrameRate reading

```
[C++]    PvDevice.GetGenParameters()->GetFloatValue("AcquisitionFrameRate", &doubleValue);
[C#]     doubleValue = PvDevice.GenParameters.GetFloatValue("AcquisitionFrameRate");
```

9.11.3 Enumeration type parameter control

Enumeration type parameter such as "BalanceWhiteAuto" control.

e.g. BalanceWhiteAuto writing

```
[C++]    PvDevice.GetGenParameters()->SetEnumValue("BalanceWhiteAuto", "Continuous");
[C#]     PvDevice.GenParameters.SetEnumValue("BalanceWhiteAuto", "Continuous");
```

e.g. BalanceWhiteAuto reading

```
[C++]    PvDevice.GetGenParameters()->GetEnumValue("BalanceWhiteAuto", &PvStringValue);
[C#]     stringValue = PvDevice.GenParameters.GetEnumValueAsString("BalanceWhiteAuto");
```

9.11.4 String type parameter control

String type parameter such as "DeviceModelName" control.

e.g. DeviceModelName writing (DeviceModelName cannot overwrite)

```
[C++]    PvDevice.GetGenParameters()->SetString("DeviceModelName", "STC-SB33POE");
[C#]     PvDevice.GenParameters.SetStringValue("DeviceModelName", "STC-SB33POE");
```

e.g. DeviceModelName reading

```
[C++]    PvDevice.GetGenParameters()->GetString("DeviceModelName", &PvStringValue);
[C#]     stringValue = PvDevice.GenParameters.GetStringValue("DeviceModelName");
```

9.11.5 Boolean type parameter control

Boolean type parameter such as "LineInverter0" control.

e.g. LineInverter0 writing

```
[C++]    PvDevice.GetGenParameters()->SetBooleanValue("LineInverter0", true);
[C#]     PvDevice.GenParameters.SetBooleanValue("LineInverter0", true);
```

e.g. LineInverter0 reading

```
[C++]    PvDevice.GetGenParameters()->GetBooleanValue("LineInverter0", &boolValue);
[C#]     boolValue = PvDevice.GenParameters.GetBooleanValue("LineInverter");
```

9.11.6 Command type parameter control

Command type parameter such as "TriggerSoftware"

e.g. TriggerSoftware generating

```
[C++]    PvDevice.GetGenParameters()->ExecuteCommand("TriggerSoftware");
[C#]     PvDevice.GenParameters.ExexuteCommand("TriggerSoftware");
```

9.12 GenICam Command List

9.12.1 DeviceControl

Name	Description
DeviceVendorName	Name of the manufacturer of the device.
DeviceModelName	Model of the device.
DeviceManufacturerInfo	Manufacturer information about the device.
DeviceVersion	Version of the device.
DeviceID	Device's serial number.
DeviceUserID	User-programmable device identifier.
DeviceScanType	Scan type of the sensor of the device.
DeviceTemperature	Device temperature in degrees Celsius $^{\circ}$.
DeviceReset	Reset the device to its power up state.

9.12.2 ImageFormatControl

Name	Description
SensorDigitizationTaps	Number of digitized samples outputted simultaneously by the camera A/D conversion stage.
Width	Width of the image provided by the device (in pixels).
Height	Height of the image provided by the device (in pixels).
SensorShutterMode	Sets the shutter mode of the device.
DecimationHorizontal	Horizontal sub-sampling of the image. This reduces the horizontal resolution (width) of the image by the specified horizontal decimation factor.
DecimationVertical	Vertical sub-sampling of the image. This reduces the vertical resolution (height) of the image by the specified vertical decimation factor.
PixelFormat	Format of the pixels provided by the device. It represents all the information provided by PixelCoding, PixelSize, PixelColorFilter combined in a single feature.
PixelCoding	Coding of the pixels in the image, Raw gives the data in the native format of the sensor.
PixelSize	Total size in bits of a pixel of the image.
PixelColorFilter	Type of color filter that is applied to the image.
TestImageSelector	Selects the type of test image that is sent by the camera.
OffsetX	Horizontal offset from the origin to the region of interest (in pixels).
OffsetY	Vertical offset from the origin to the region of interest (in pixels).

9.12.3 AcquisitionControl

Name	Description
AcquisitionMode	Sets the acquisition mode of the device. It defines mainly the number of frames to capture during an acquisition and the way the acquisition stops.
AcquisitionStart	Starts the Acquisition of the device. The number of frames captured is specified by AcquisitionMode.
AcquisitionStop	Stops the Acquisition of the device at the end of the current Frame. It is mainly used when AcquisitionMode is Continuous but can be used in any acquisition mode.
AcquisitionFrameCount	Number of frames to acquire in MultiFrame Acquisition mode.
AcquisitionFrameRate	Controls the acquisition rate (in Hertz) at which the frames are captured.
TriggerSelector	Selects the type of trigger to configure.
TriggerMode	Controls if the selected trigger is active.
TriggerSoftware	Generates an internal trigger. TriggerSource must be set to Software.
TriggerSource	Specifies the internal signal or physical input Line to use as the trigger source. The selected trigger must have its TriggerMode set to On.
TriggerActivation	Specifies the activation mode of the trigger.
TriggerDelay	Specifies the delay in microseconds (us) to apply after the trigger reception before activating it.
ExposureMode	Sets the operation mode of the Exposure (or shutter).
ExposureTime	Sets the Exposure time when ExposureMode is Timed and ExposureAuto is Off. This controls the duration where the photosensitive cells are exposed to light.
ExposureTimeAbs	Sets the Exposure time when ExposureMode is Timed and ExposureAuto is Off. This controls the duration where the photosensitive cells are exposed to light.
ExposureTimeRaw	Sets the Exposure time when ExposureMode is Timed and ExposureAuto is Off. This controls the duration where the photosensitive cells are exposed to light.
ExposureAuto	Sets the automatic exposure mode when ExposureMode is Timed. The exact algorithm used to implement this control is device-specific.

9.12.4 DigitalIOControl

Name	Description
LineDebounceTime	Sets the value of the input line debouncer time.
LineSource0	Set the output signals from the power / IO connector.
LineSource1	Set the output signals from the power / IO connector.
UserOutputValue0	Sets the value of the bit selected by LineSource0.
UserOutputValue1	Sets the value of the bit selected by LineSource1.
StrobeSignalDelay	Specifies the delay in microseconds (us) to apply the trigger reception before activating strobe signal.
StrobeSignalOnTime	Specifies the strobe signal active time in microseconds (us).
LineInverter0	Controls the inversion of the signal of the selected output line of LineSource0.
LineInverter1	Controls the inversion of the signal of the selected output line of LineSource1.

9.12.5 CounterAndTimerControl

Name	Description
CounterSelector	Selects which Counter to configure.
CounterEventSource	Select the events that will be the source to increment the Counter.
CounterDecrementEventSource	Selects the event that decrements the counter.
CounterResetSource	Selects the signals that will be the source to reset the Counter.
CounterResetActivation	Selects the Activation mode of the Counter Reset Source signal.
CounterValue	Reads or writes the current value of the selected Counter.
CounterDuration	Sets the duration (or number of events) before the CounterEnd event is generated.
CounterStatus	Returns the current status of the Counter.
CounterTriggerSource	Selects the source to start the Counter.
TimerSelector	Selects which Timer to configure.
TimerDurationRaw	It sets the duration in device-specific unit of the Timer pulse.
TimerDelayRaw	It sets the duration in device-specific unit of the delay to apply after the reception of a trigger before start the Timer.
TimerTriggerSource	Selects the source of the trigger to start the Timer.
TimerTriggerActivation	Selects the activation mode of the trigger to start the Timer.
TimerGranularityFactor	Controls the granularity of the TimerDurationRaw and TimerDelayRaw features (in increments of up to 30 nseconds).
TimerPeriod	Returns the period, in ns, of the selected timer.
TimerFrequency	Returns the frequency, in Hertz, of the selected timer.

9.12.6 EventControl

Name	Description
PLC	Category that contains the PLC event features.
IPEngineCamHeadSerialComLog	Category that contains the IP engine to camera head serial communication log event features.
EventSelector	Selects which Event to signal to the host application.
EventNotification	Activate or deactivate the notification to the host application of the occurrence of the selected Event.

9.12.7 AnalogControl

Name	Description
GainSelector	Selects which Gain is controlled by the various Gain features.
Gain	Controls the selected gain as an absolute physical value. This is an amplification factor applied to the video signal.
GainRaw	Controls the selected gain as an absolute physical value. This is an amplification factor applied to the video signal.
GainAbs	Controls the selected gain as an absolute physical value. This is an amplification factor applied to the video signal.
GainAuto	Sets the automatic gain control (AGC) mode. The exact algorithm used to implement AGC is device-specific.
BlackLevelSelector	Selects which Black Level is controlled by the various Black Level features.
BlackLevel	Controls the black level as an absolute physical value. This represents a DC offset applied to the video signal.

9.12.8 TransportLayerControl

Name	Description
PayloadSize	Provides the number of bytes transferred for each image or chunk on the stream channel.
GevVersionMajor	Major version of the specification.
GevVersionMinor	Minor version of the specification.
GevVDeviceModelsBigEndian	Endianess of the device registers.
GevDeviceClass	Returns the class of the device.
GevDeviceModeCharacterSet	Character set used by all strings of the bootstrap registers.
GevInterfaceSelector	Selects which physical network interface to control.
GevMACAddress	MAC address of the network interface.
GevSupportedOptionSelector	Selects the GEV option to interrogate for existing support.
GevSupportedOption	Returns if the selected GEV option is supported.
GevCurrentIPConfigurationLLA	Controls whether the Link Local Address IP configuration scheme is activated on the given network interface.
GevCurrentIPConfigurationDHCP	Controls whether the DHCP IP configuration scheme is activated on the given network interface.
GevCurrentIPConfigurationPersistent	Controls whether the Persistent IP configuration scheme is activated on the given network interface.
GevCurrentIPAddress	Reports the IP address for the given network interface.
GevCurrentSubnetMask	Reports the subnet mask of the given network interface.
GevCurrentDefaultGateway	Reports the default gateway IP address to be used on the given network interface.
GevIPConfigurationStatus	Reports the current IP configuration status.
GevFirstURL	Indicates the first URL to the XML device description file.
GevSecondURL	Indicates the second URL to the XML device description file.
GevNumberOfInterface	Indicates the number of physical network interfaces supported by this device.
GevPersistentIPAddress	Controls the Persistent IP address for this network interface.
GevPersistentSubnetMask	Controls the Persistent subnet mask associated with the Persistent IP address on this network interface.
GevPersistentDefaultGateway	Controls the Persistent default gateway for this network interface.
GevMessageChannelCount	Indicates the number of message channels supported by this device.
GevStreamChannelCount	Indicates the number of stream channels supported by this devices.
GevHeartbeatTimeout	Controls the current heartbeat timeout in milliseconds.
GevTimestampCounterSelector	Selects the source counter for GigE Vision timestamps.
GevTimestampSetSource	Selects the signal that sets the counter to <code>GevTimestampValueAtSet</code> .
GevTimestampSetActivation	Selects the activation mode for the counter set source signal.
GevTimestampValueAtSet	Controls the value to be set in the counter when the set event occurs.
GevTimestampResetSource	Selects the signal that resets the counter (to 0).
GevTimestampResetActivation	Selects the activation mode for the counter reset source signal.
GevTimestampTickFrequency	Indicates the number of timestamp ticks in 1 second (frequency in Hz).
GevTimestampControlLatch	Latches the current timestamp counter into <code>GevTimestampValue</code> .
GevTimestampControlSet	Sets the counter to <code>GevTimestampValueAtSet</code> .
GevTimestampControlReset	Rests the timestamp counter to 0.
GevTimestampValue	Returns the latched 64-bits value of the timestamp counter.
GevCCP	Controls the device access privilege of an application.
GevMCPHostPort	Controls the port to which the device must send message.
GevMCDA	Controls the destination IP address for the message channel.

Name	Description
GevMCTT	Provides the transmission timeout value in milliseconds.
GevMCRC	Controls the number of retransmissions allowed when a message channel message time out.
GevMCSP	This feature indicates the source port for the message channel.
GevStreamChanelSelector	Selects the stream channel to control.
GevSCPDirection	Reports the direction of the stream channel.
GevSCPInterfaceIndex	Index of network interface to use.
GevSCPHostPort	Controls the port of the selected channel to which a GVSP transmitter must send data stream or the port from which a GVSP receiver may receive data stream.
GevSCPFireTestPacket	Sends a test packet.
GevSCPSPDoNotFragment	The state of this feature is copied into the "do not fragment" bit of IP header of each stream packet.
GevSCPSPBigEndian	Endianess of multi-bytes pixel data for this stream.
GevSCPSPPacketSize	Specifies the stream packet size, in bytes, to send on the selected channel for a GVSP transmitter or specifies the maximum packet size supported by a GVSP receiver.
GevSCPD	Controls the delay (in timestamp counter unit) to insert between each packet for this stream channel.
GevSCDA	Controls the destination IP address of the selected stream channel to which a GVSP transmitter must send data stream or this destination IP address from which a GVSP receiver may receive data stream.
GevSCSP	Indicates the source port of the stream channel.

9.12.9 UserSetControl

Name	Description
UserSetSelector	Selects the feature User Set to load, save or configure.
UserSetLoad	Loads the User Set specified by UserSetSelector to the device and makes it active.
UserSetSave	Save the User Set specified by UserSetSelector to the non-volatile memory of the device.
UserSetDefaultSelector	Selects the feature User Set to load and make active by default when the device is reset.

9.12.10 IPEngine

Name	Description
ProgrammableLogicController	Category that contains the Programmable Logic Controller (PLC) features.

9.12.11 SpecialFeatures

Name	Description
SmearHalfReduction	The upper half of smear is reduced when select "ON".
DoubleSpeedMode	Set double frame rate mode. The number of the maximum horizontal pixels (width) is limited.
DoubleSpeedModeTapsel	Horizontal pixels region (tap) at DoubleSpeedMode.
HDRSloop	HDR mode can choose 2 sloop and 3 sloop mode.
HDRKnee1	Set the ExposureTime for HDRKnee1 point.
HDRKnee2	Set the ExposureTime for HDRKnee2 point.
HDRVlow1	Set the voltage of HDRVlow1 for the HDR saturation level voltage.
HDRVlow2	Set the voltage of HDRVlow2 for the HDR saturation level voltage.
VerticalStripCorrection	Correct the vertical stripe when select "ON".
ReloadGammaData	Gamma table reload from EEPROM to RAM.
GammaMode	Gamma mode selection.
Min_ShutterTime	Minimum shutter speed for Auto shutter control mode. Unit: us.
Max_ShutterTime	Maximum shutter speed for Auto shutter control mode. Unit: us
AGCRange	Maximum gain value for AGC.
TargetBrightness	Target brightness for ALC.
ALC_Peak_Average	Ratio of peak and average fro ALC.
DigitalGain	Digital gain
ALCWeight1	Weight of the area determined by ALCWindowV1, ALCWindowV2, ALCWindowH1 and ALCWindowH2 for ALC.
ALCWeight2	Weight of the area determined by ALCWindowV1, ALCWindowV2, ALCWindowH2 and ALCWindowH3 for ALC.
ALCWeight3	Weight of the area determined by ALCWindowV1, ALCWindowV2, ALCWindowH3 and ALCWindowH4 for ALC.
ALCWeight4	Weight of the area determined by ALCWindowV2, ALCWindowV3, ALCWindowH1 and ALCWindowH2 for ALC.
ALCWeight5	Weight of the area determined by ALCWindowV2, ALCWindowV3, ALCWindowH2 and ALCWindowH3 for ALC.
ALCWeight6	Weight of the area determined by ALCWindowV2, ALCWindowV3, ALCWindowH3 and ALCWindowH4 for ALC.
ALCWeight7	Weight of the area determined by ALCWindowV3, ALCWindowV4, ALCWindowH1 and ALCWindowH2 for ALC.
ALCWeight8	Weight of the area determined by ALCWindowV3, ALCWindowV4, ALCWindowH2 and ALCWindowH3 for ALC.
ALCWeight9	Weight of the area determined by ALCWindowV3, ALCWindowV4, ALCWindowH3 and ALCWindowH4 for ALC.
ALCWindowV1	1 st vertical line (1 st from the top) position for the area for ALC.
ALCWindowV2	2 nd vertical line (2 nd from the top) position for the area for ALC.
ALCWindowV3	3 rd vertical line (3 rd from the top) position for the area for ALC.
ALCWindowV4	4 th vertical line (4 th from the top) position for the area for ALC.
ALCWindowH1	1 st horizontal (1 st from the left) position for the area for ALC.
ALCWindowH2	2 nd horizontal (2 nd from the left) position for the area for ALC.
ALCWindowH3	3 rd horizontal (3 rd from the left) position for the area for ALC.
ALCWindowH4	4 th horizontal (4 th from the left) position for the area for ALC.

Name	Description
ALCWindowH1	1 st horizontal (1 st from the left) position for the area for ALC.
ALCWindowH2	2 nd horizontal (2 nd from the left) position for the area for ALC.
ALCWindowH3	3 rd horizontal (3 rd from the left) position for the area for ALC.
ALCWindowH4	4 th horizontal (4 th from the left) position for the area for ALC.
WB_WindowH1	Horizontal start position of the area for auto white balance (Horizontal start position from left)
WB_WindowH2	Horizontal end position of the area for auto white balance (Horizontal end position from left)
WB_WindowV1	Vertical start position of the area for auto white balance (Vertical start position from left)
WB_WindowV2	Vertical end position of the area for auto white balance (Vertical end position from left)
WB_WindowMode	Select white balance window mode.
YThreshold	The value for auto white balance is determined with the color information of the pixels, which is more than this threshold.
ModeCode	Mode code.
HardwareVersion	Hardware version.
FPGA FirmwareVersion	FPGA Firmware Version.
FirmwareVersion	Firmware Version.
SerialNumber	Serial number.
CustomerCode	Customer code.

Aegis Electronic Group, Inc.

Aegis Electronic Group, Inc.

OMRON SENTECH CO., LTD.

 (888)687-6877
ELECTRONIC GROUP, INC
