



### VMOB-17 Series

#### 17" Daylight Viewable Industrial-Grade LCD Monitors

- Optical Bonding For Increased Contrast Ratio
- Protective Anti-Reflective Glass
- High Resolution: 1280 x 1024 (SXGA)
- Video Inputs: VGA, DVI-D, Composite (BNC Loop-Thru)
- Lockable On-Screen Display (OSD) Controls
- Auto Re-Start After Power Loss
- **TRU-Tuff** Ensures Maximum Shock/Vibration Resistance
- 3 Year Warranty

The VMOB-17 Series are optically bonded LCD monitors, designed to dramatically improve viewability in bright daylight and other high ambient light conditions. The optical bonding process injects an optical-grade epoxy resin between the LCD panel and the outer protective glass, eliminating the air gap between the two. The outer glass surface has an Anti-Reflective coating. The net result is a dramatic reduction in unwanted reflections, and a tremendous increase in contrast ratio, making the monitor ideal for use in outdoor daylight or brightly lit areas. Optical bonding also provides other benefits such as increased ruggedness and durability, prevents internal condensation or fogging, and makes the outer glass shatter-proof.

The VMOB-17 Series daylight viewable LCD monitors are built with industrial grade components, and receive our exclusive **TRU-Tuff** treatment. The **TRU-Tuff** process includes: RTV silicone on all connections and critical components; all wires are dressed, tie-wrapped and secured; and ThreadLock on all screws. This ensures maximum shock and vibration resistance. These monitors are ideal for wide range of demanding applications including industrial, military, law enforcement, transportation, aviation, marine, inspection, cranes, oceanic, and entertainment.

	Specifications				
MODEL	VMOB-17C	VMOB-17B	VMOB-17B-36	VMOB-17G-36	VMOB-17C-H
LCD Panel	17" Color LCD (LED Backlights)				
Display Resolution	1280 x 1024 (SXGA)				
Viewable Area	13.3" (W) x 10.64" (H) (337.92 x 270.34 mm)				
Pixel Pitch	0.264mm				
Display Colors	16.7 M				
Aspect Ratio	4:3 (5:4)				
Brightness	300 nits		350 nits		
Contrast Ratio	1,000:1				
Viewing Angle	170° (H) x 160° (V)		160° (H) x 140° (V)		
Response Time	5 msec		30 msec		
Control	OSD (On-Screen Display) via Front Panel Pushbuttons				
Video Inputs	VGA, DVI	VGA, Composite BNC Loop-Thru; NTSC/PAL Auto Recognition		VGA, DVI	
Analog Video Outputs	-	1 BNC Output		-	
Internal Speakers	Optional				
Power Requirement	12 VDC (2.1 mm Barrel Plug); (90-240 VAC via Included Power Brick)				
Power Consumption	40 Watts				
Enclosure	ABS				
Mounting	75x75mm Rear VESA Mount Holes (Optional Tabletop Base)				
Operating Temp.	14° to 122° F (-10° to 50° C)		-22° F to + 185°F(-30° to +85°C)		
Humidity	5-90% RH				
Shock	50 G (20 msec, ½ sine)				
Vibration	1.5G RMS 10-200 HZ				
Dimensions	14.95 (W) x 13.54" (H) x 1.9" (D) (379.8 x 344 x 47.2mm)				
Weight	6.9 blbs. (2.99kg)				
Warranty	3 Years				

## VMOB-17 Series

### 17" Daylight Viewable Industrial-Grade LCD Monitors

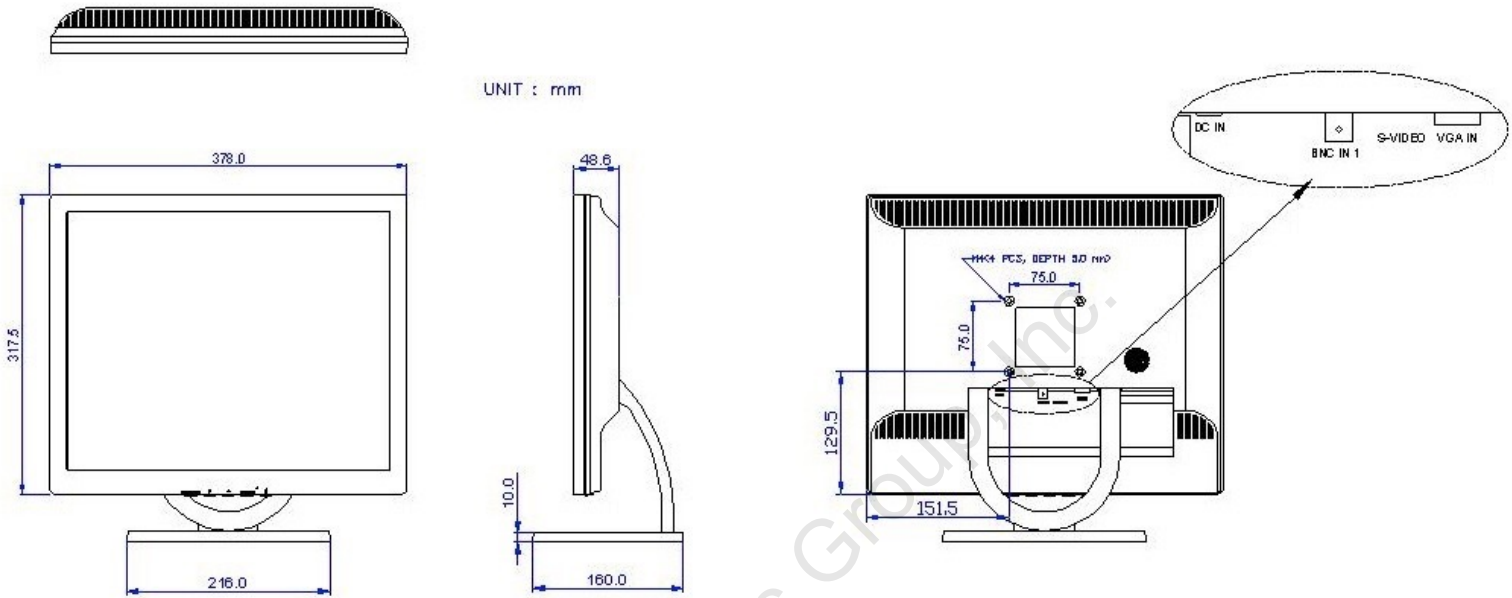

#### Standard Accessories:

- 90-240 VAC Power Supply
- Tabletop Stand
- VGA Cable

#### Available Options:

- Waterproof Enclosure
- Panel Mount Bracket
- Touch Screen
- Rack Mount Bracket
- Open-Frame Configuration
- Private Label
- Other Customer - Specific Modifications

