

# Pixelink®

A NANITAR COMPANY

## PL-D755MU-POL

CMOS | SONY IMX250MZR | GLOBAL SHUTTER

The PL-D755MU-POL polarization machine vision camera, featuring the Sony IMX250MZR image sensor, offers broader visual detection and characterization capabilities of material properties and improved performance over conventional monochrome sensors.

The PL-D755MU-POL has a 2/3" optical format, 3.45 micron pixel resolution and is available in board level or enclosed configurations.

The IMX250MZR sensor is designed with Sony's innovative pixel-level quad polarization filter technology, where four polarizer positions, one per pixel, are angled at 0°, 45°, 90° and 135°, to enable greater detection of both the amount and angles of polarized light across an image. By filtering unwanted reflections and reducing glare, imaging previously undetectable defects, such as scratches, stress on materials and transparent objects, is now possible.

As with all Pixelink cameras, the PL-D755MU-POL is compatible with Pixelink Capture, our free real-time interactive multi-camera software.



### KEY FEATURES

-   
**5MP**  
 CMOS
-   
**53**  
 FRAMES  
 Per Sec.
-   
**3.45µm**
-   
**11.1mm**
-   
 Sensor  
 Size  
**2/3"**
-   
**12 BIT**
-   
**MONO**
-   
**USB 3**
-   
**USB**  
 VISION

### TYPICAL APPLICATIONS

- Parts Inspection
- Scratch Inspection
- Medical Imaging
- Strength/Stress Testing
- Metrology
- PCB & Flat Panel Display Inspection
- Traffic Enforcement
- Biometrics

## TECHNICAL SPECIFICATIONS

### SENSOR

Sensor	Sony IMX250MZR
Type	CMOS Global Shutter
Resolution	5.01 MP (1224 x 1024)
Pixel Pitch	3.45 $\mu\text{m}$ x 3.45 $\mu\text{m}$
Active Area	11.1 mm diagonal

### PERFORMANCE SPECIFICATIONS

FPN	< 0.03% of signal
PRNU	< 0.4% of signal
Dynamic Range	70 dB
Bit Depth	12-bit
Polar Data Formats	Stokes Polar HSV

### FRAME RATES

Effective Resolution	Free Running
1224 x 1024	53 fps

Frame rates will vary based on host system and configuration  
\*Above calculations based on fixed frame rate mode

### INTERFACES

Interface   Date rate	USB 3.0   Micro-B   5Gbps
Board Level Trigger Connector	8-pin Molex 1.25mm pitch
Enclosed Trigger Connector	Hirose round 8-pin
Trigger	Software and hardware
Board Level Trigger Input	1 input, 3.3V (with internal pullup resistor)
Enclosed Trigger Input	1 optically Isolated, 5-12V DC at 4-11 mA
Board Level GPO/Strobe	2 outputs, 3.3V
Enclosed GPO/Strobe	2 outputs, 3.3V and 1 optically isolated max 40V DC, max 15mA
GPI	1 input, 3.3V (with internal pullup resistor)

### MECHANICALS

Dimensions (mm)	55 x 38.5 x 30.29
Weight (g)	35.8 (Board level without optics)
Mounting	C-Mount and S-Mount

### POWER REQUIREMENTS

Voltage Required	5V DC (from USB connector)
------------------	----------------------------

### PIN NAME & FUNCTION

1	3.3V power output
2	TRIGGER/GPI 3.3V HCMOS input
3	Ground
4	GPO1, 3.3V HCMOS output
5	GPO2, 3.3V HCMOS output
6	Clock, 3.3V (I2C access for OEMs)
7	Data, 3.3V (I2C access for OEMs)
8	No connection

Board connector: Molex (8-pin, 1.25mm pitch, vertical); Cable receptacle: Molex 51021-0800; Cable crimp terminals: Molex 50079-8100

### ENCLOSED GPIO INTERFACE PIN OUTPUT DESCRIPTION

1	VBUS (Power output from USB3 cable)
2	TRIGGER + (optically isolated)
3	TRIGGER - (optically isolated)
4	GPO1 + (optically isolated)
5	GPO1 - (optically isolated)
6	GPO1, 3.3V HCMOS output (I2C - SCL for autofocus)
7	GPO2, 3.3V HCMOS output (I2C - SDA for autofocus)
8	Ground (logic and chassis ground)

### ENVIRONMENTAL & REGULATORY

Compliance	FCC, CE & RoHS
Shock & Vibration	300 G & 20 G (10Hz - 2KHz)
Operating Temperature	0°C to 50°C
Storage Temperature	-45°C to 85°C

### SOFTWARE

Pixelink Capture	Control & operate multi-camera
Pixelink SDK	Software Development Kit
Pixelink $\mu$ Scope	Acquisition, analysis & reporting
3 <sup>rd</sup> Party U3V Vision Applications	

### COMPUTER & OPERATING SYSTEM

	Windows	Linux x86	Linux ArmV7	Linux ArmV8
Processor	Intel i5 or better	Intel i5 or better	Arm7 (32 bit)	Arm8 (64 bit)
Memory	4GB recommended	4GB recommended	2GB	2GB
Hard Drive Space	150 MB	150 MB	50 MB	50 MB
Operating System	Windows 7/8/10	Ubuntu 14.04/16.04 Desktop	Ubuntu 14.04/16.04	Ubuntu 14.04/16.04

MECHANICAL DRAWINGS

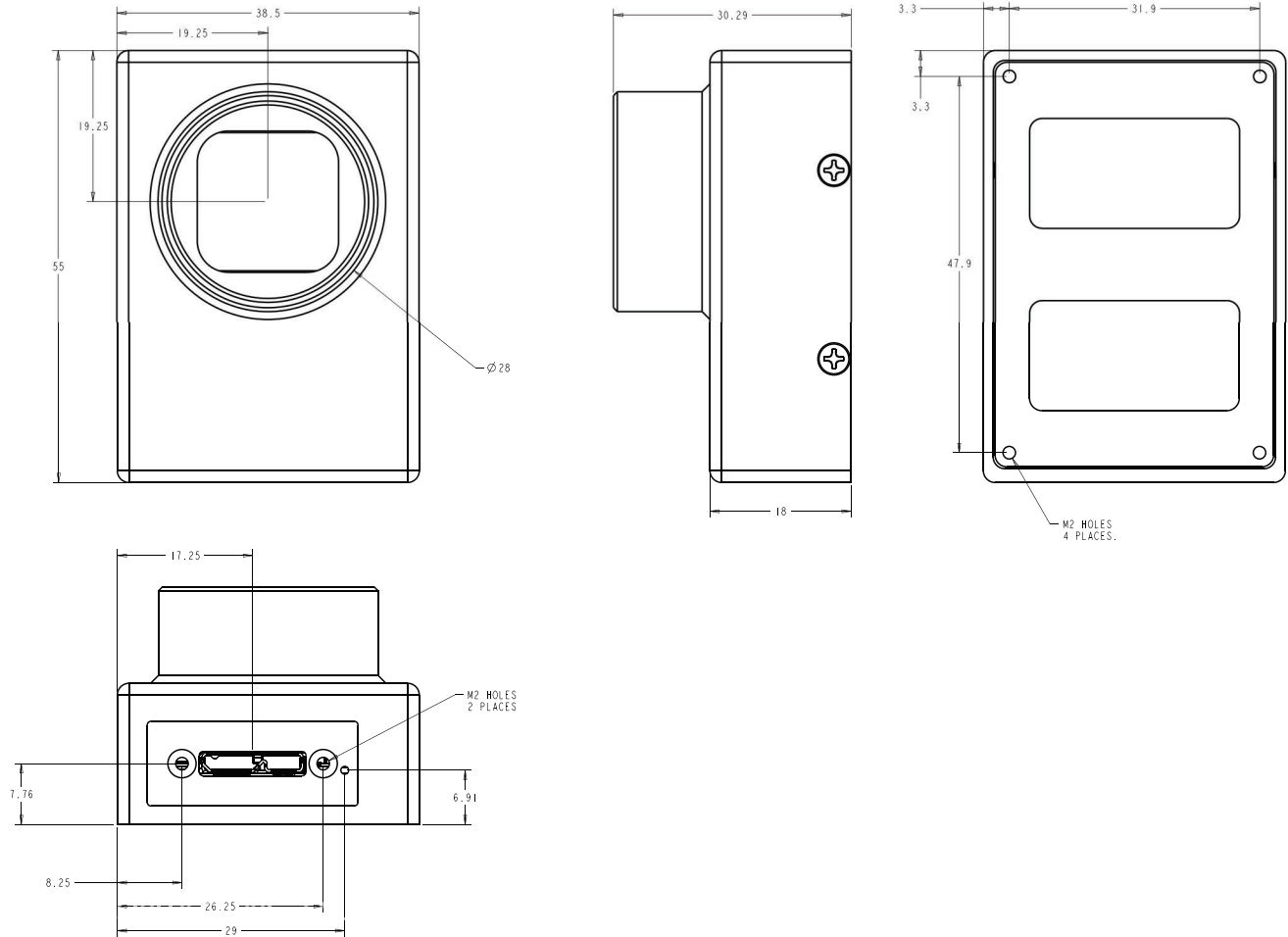

OMNIDIRECTIONAL EXTINCTION RATIO (MIN.)

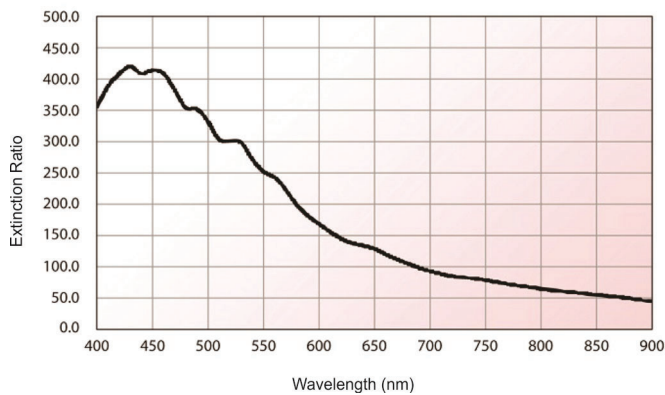

## INDUSTRY LEADING SOFTWARE

### PIXELINK CAPTURE

Pixelink Capture is powerful multi-camera software application designed to configure “n” numbers of cameras and stream “n” number of cameras simultaneously in real-time high-quality video viewed in a multi-window environment. Pixelink Capture offers options for complex image enhancements such as exposure control and filtering, in addition to multi-camera application testing and configuration.

Pixelink Capture also provides features to measure supporting point, line, circle, rectangle, polyline and polygon measurements while determining pixel location. The user can review and adjust the data before exporting the findings to an Excel spreadsheet for further analysis.

Pixelink Capture also has integrated lens control (zoom & focus) for Navitar motorized lenses and accurate autofocus options for Navitar motorized fine focus mechanisms.

For more information on Pixelink Capture and our SDK, please visit [pixelink.com](http://pixelink.com)

### PIXELINK SDK

Providing full control of all camera functions, the Pixelink Software Development Kit (SDK) is the software package of choice for developers and system integrators who are integrating Pixelink cameras into their applications. The Pixelink SDK provides access to the full Pixelink Application Programming Interface (API) and provides sample applications, wrappers for many 3rd party controls, such as LabVIEW, along with full documentation.

The Pixelink SDK is compatible with Microsoft Windows and popular Linux platforms. When using the Pixelink SDK, developers can integrate Pixelink cameras into their custom applications with ease.

## AVAILABLE CONFIGURATIONS

PL-D755MU-POL  
PL-D755MU-BL-POL  
PL-D755MU-T-POL

#### Color Space

C = Color  
M = Mono  
NIR = Near Infrared  
POL = Polarized

#### Interface

F = Firewire  
G = GigE  
U = USB

#### Housing

CS = CS Mount  
S-BL = S Mount Board Level  
BL = Board Level  
T = Trigger

#### Autofocus

AF = Autofocus Lens (in mm)