

**XCU-CG160 (B/W)** **(NEW)**  
**XCU-CG160C (Color)** **(NEW)**

USB3 Vision Progressive Scan 1/2.9type GS CMOS Square Pixels C Lens Mount 1.6 MEGA Output Aria Gain Image Flip

Long Exposure Normal Shutter External Trigger Shutter Auto Shutter Burst Trigger Trigger range Partial Scan Multi ROI Shading Correction

Temperature Readout Defect Correction \*1 One-Push White Balance \*1 Manual White Balance LUT \*2 B/W \*1 RGB RAW \*2 Near-IR Sensitivity

\*1 : XCU-CG160C

\*2 : XCU-CG160

Connection Diagram **P45**



**Pregius** *Exmor*

**USB3 Vision support**

**Outline**

A new series of the USB3 Vision interface digital cameras equipped with the global shutter CMOS sensor. Achieved 1.6Mega, 100fps in a compact size of 29(W) x 29(H) x 30(D)mm. With an excellent system construction cost performance as well as inheriting characteristics of analog cameras such as their body size and high reliability, the series is optimal for replacing old models. Easy-to-use through PC connection with plug and play.

**Features**

■ High frame rate  
 You can select either the mode that gives priority to the frame rate or one that enables the use of all functions.

Model	Priority to the frame rate		Use of all functions	
	Fast	Normal	Fast	Normal
XCU-CG160 XCU-CG160C	Raw 8 bit	100 fps	8/12 bit	56 fps
			YCbCr422	49 fps
			RGB	32 fps
			YCbCr444	

■ Area Gain → See page 8  
 You can set the individual digital gain (0 to 32times) to 16 optional rectangular areas. In the case that multiple rectangular areas overlap, the gain value with the smaller area number will have priority. The image can be optimized to suit the subject (part), in applications such as part inspection.

■ Image Flip  
 You can flip the image vertically or horizontally, or rotate it 180 degrees.

		ReverseX	
		False (0)	True (1)
ReverseY	False (0)	Normal	Flip horizontally
	True (1)	Flip vertically	Rotate 180 degrees

■ Defect Correction  
 This function is useful for applications that require high resolution. It corrects clear defect points and opaque defect points of the image sensor. It can also correct any white or black flecks that may appear in the image due to factors such as cosmic rays. From the peripheral pixels, correction is performed on coordinate pixels in which defects are detected. Factory setting and user setting can be selected.

\* Factory setting :ON

- Shading Correction → See page 9  
 Depending on the characteristic of the lens, shadings caused by a drop in the amount of light around the lens, or light source variation, are corrected.  
 XCU-CG160/CG160C: 31 patterns
- 3 x 3 filter  
 Utilizing the 3 x 3 filter, you can obtain images in various processing conditions. Depending on the patterns of parameters, you can reduce noise, apply edge enhancement and extract the contour.

3 x 3 filter: OFF



Laplacian filter



- Multi ROI  
 Arbitrarily read out images including any 2 (max.) rectangular area from the maximum effective imaging area. Due to this, you will be capable of limiting read out information, thus accelerating the frame rate.

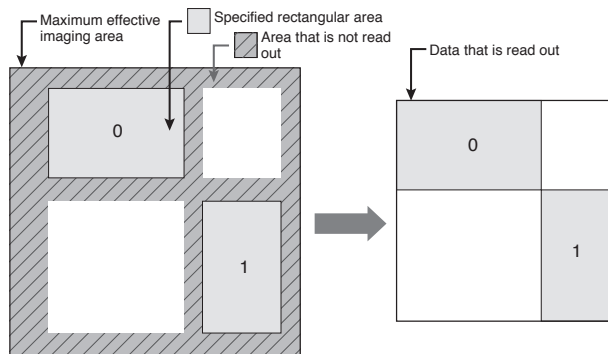

## Preliminary

### ■ Binning

Supports binning in vertical and horizontal 2 pixel units and increases frame rate without changing the angle of view as well as enhances the sensitivity.

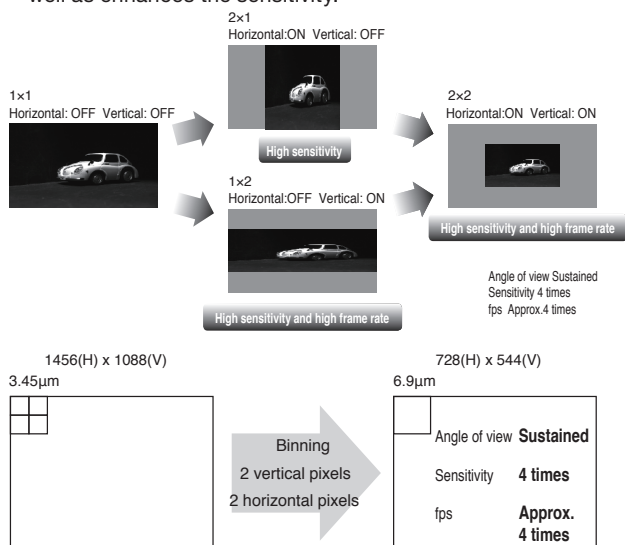

- Temperature Readout
- LUT (Look up Table)
- Trigger Range Limit
- Burst trigger
- USB3 Vision
- Mass : 50 g

## Pregius

Pregius is a trademark of Sony Corporation. The Pregius is global shutter pixel technology for active pixel-type CMOS image sensors that use Sony's low-noise CCD structure, and realizes high picture quality.

## Accessories

- Compact camera adaptor : DC-700/700CE
- Tripod adaptor : VCT-333I

## Dimensions

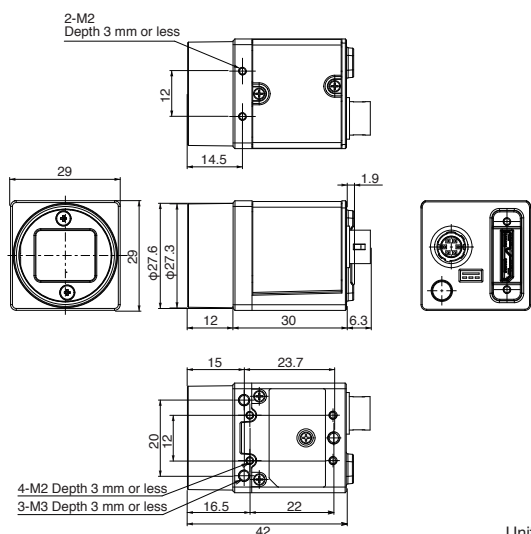

Unit : mm

## Spectral Sensitivity Characteristics

### B/W model

#### • XCU-CG160

(Lens characteristics and light source characteristics excluded.)

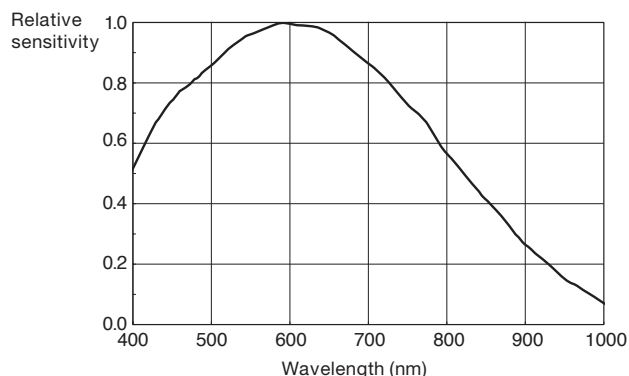

### Color model

#### • XCU-CG160C

(Lens characteristics and light source characteristics excluded.)

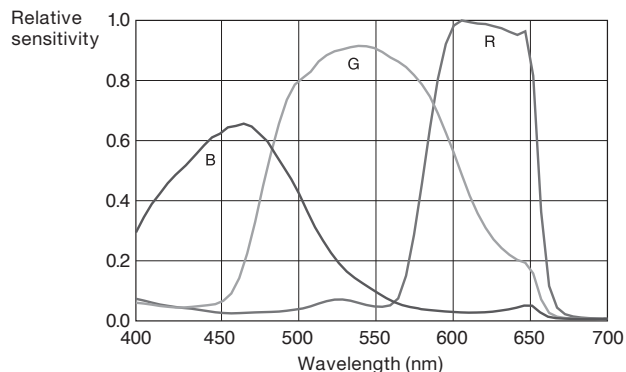

## Location and Function of Parts and Controls

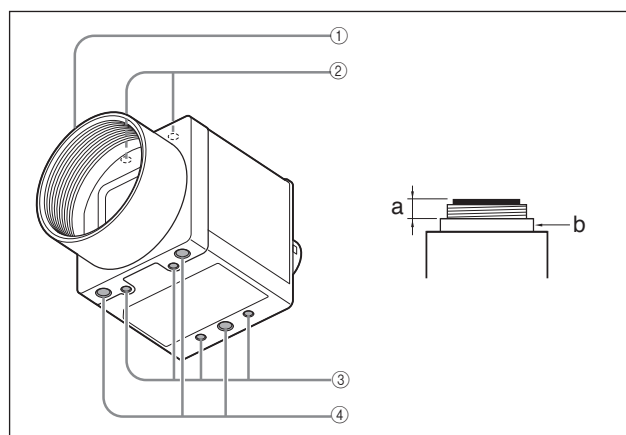

### ① Lens mount (C-mount)

Attach any C-mount lens or other optical equipment.

#### Note

Use a C-mount lens with a protrusion (a) extending from the lens mount face (b) of 10 mm (13/32 inch) or less.

### ② Guide screw holes (Top)

### ③ Guide screw holes/Tripod screw holes (bottom)

When using a tripod, use these four screw holes to attach a VCT-333I tripod adaptor.

### ④ Reference screw holes (bottom)

These precision screw holes are for locking the camera module. Locking the camera module into these holes secures the optical axis alignment.

## Connecting the Cables

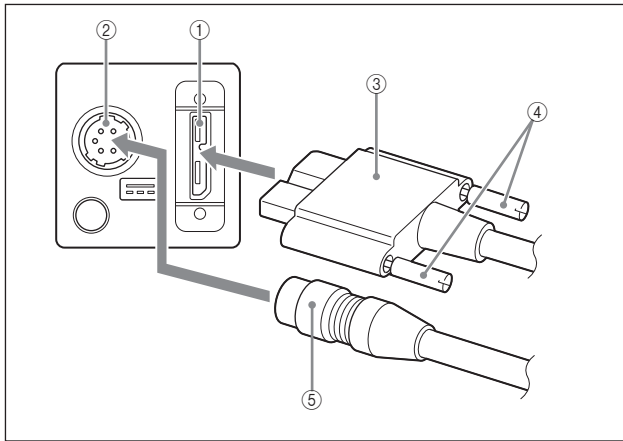

Connect the camera cable to the DC IN connector, and connect a USB 3.0 cable to the USB connector. If using a USB 3.0 interface image input board or a hub, you can operate the camera even if you do not connect the camera cable to the DC IN connector. If you connect a USB 3.0 cable that has fastening screws, turn the two screws on the connector to secure the cable tightly.

Connect the other end of the USB 3.0 cable to the USB 3.0 interface image input board or a hub.

- ① USB connector    ② DC IN connector    ③ USB3.0 cable  
④ Fastening screws    ⑤ Camera cable

## Rear Panel/Pin Assignments

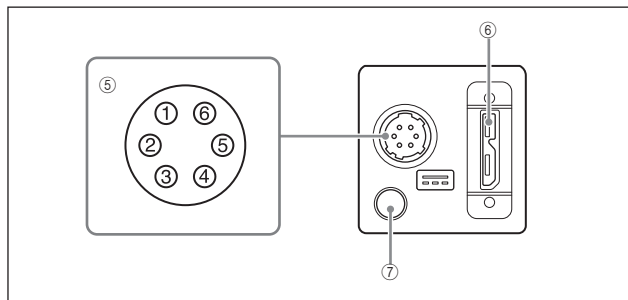

### ⑤ DC IN (DC power input) connector (6-pin)

You can connect a camera cable to input the +12 V DC power supply. The pin configuration of this connector is as follows. (Refer to part ⑤ above for the pin assignment of the connector.)

Pin No.	Signal	Pin No.	Signal
1	DC input (10.5 V to 15 V)	4	GPO3 (ISO +)
2	GPI1 (ISO +)	5	ISO -
3	GPI2/GPO2	6	GND

### ⑥ USB connector (Micro B type)

Connect a USB 3.0 cable to control the camera module from a host device and to send image signals from the camera module. Power can be supplied from a USB 3.0 interface video input board or from a USB hub over the USB 3.0 cable.

#### Note

- For safety, do not connect the connector for peripheral device wiring that might have excessive voltage to this port. Follow the instructions for this port.
- Use a Standard USB A to USB Micro B, USB 3.0 cable that is compatible with the USB3 Vision standard.
- USB 2.0 is not supported.

### ⑦ Status LED (Green)

This button is lit when power is being supplied to the camera. Various settings linked with GPO are available, such as to light up when interlocking with the trigger signal.

## Controlling the Camera From the Host Device

Control functions	Description	
Operating mode	Free run/Trigger	
Shutter speed	Free run	1/100,000 s to 60 s
	Trigger edge detection	1/100,000 s to 60 s
	Trigger pulse width detection	Setting by trigger pulse width
Gain	0 dB to 18 dB	
Partial Scan	Variable, 4-line increments (the number of settable lines are 16 or more)	
LUT (Look Up Table)	OFF/ON (Mode: 5 types)	
External trigger input	DC IN connector	
Video output switch	Monochrome model: Mono 8 / 12 bit	
	Color model: Raw 8 /12 bit, RGB24 bit, YCbCr422, YCbCr8	
Defect correction	OFF/ON	
Shading correction	OFF/ON	
Image flip	OFF/ON	
Area gain	OFF/ON	

## Trigger Signal Input

Trigger signals can be input via the 2nd, 3rd, 4th pins of the DC IN connector, or the software command. Switchover of the trigger signal can be changed via the TriggerSource register.

Register	Parameter	Setting
Trigger Source	Line1 (0)	DC IN connector 2nd pin (GPI1)
	Line2 (1)	DC IN connector 3rd pin (GPI2) *
	Software (4)	Software (TriggerSoftware register)

\*The 3rd pins of DC IN connector are available only when the input/output switching setting is set to input.

### Trigger signal polarity

Positive refers to a trigger signal polarity activated while rising from Low to Hi, or during the Hi interval.

Negative refers to a trigger signal polarity activated while falling from Hi to Low, or during the Low interval.

Register	Parameter	Setting
Trigger Activation	FallingEdge (0)	Negative
	RisingEdge (1)	Positive

### DC IN connector specifications

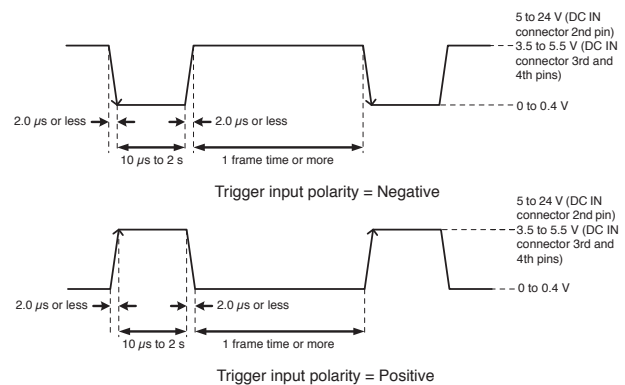

#### Note

## Trigger Modes

There are two modes, Free run, Burst Trigger.

### Free Run

The camera operates without a trigger signal and performs the video output operation continuously after the shutter (exposure) is finished when operating in Free run mode.

- Trigger edge detection (Polarity: positive)



- Trigger width detection (Polarity: positive)

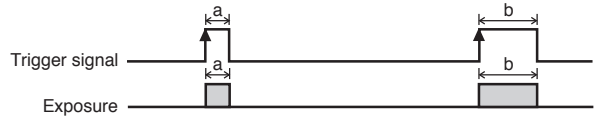

### Burst Trigger

This is a feature capable of continuous shooting at the trigger timing and specifying the number of exposures, exposure interval, and exposure time. Select from the mode that repeats one exposure time or the mode that switches between 2 exposure times repeatedly. Furthermore, there is another mode that repeats only while the trigger signal is on.

- (A) When 1 pattern of exposure time is set  
Set the number of exposures, exposure interval (1), and exposure time (2) Continuous shooting at the trigger timing

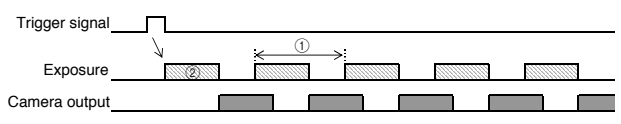

- (B) When 2 patterns of exposure times are set  
Set the number of exposures, exposure interval (1), and exposure time (2) Continuous shooting at the trigger timing

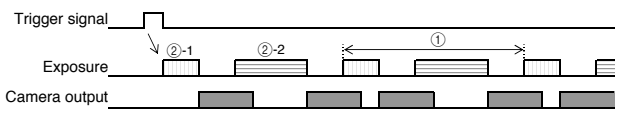

## Trigger Inhibition

Trigger input can be disabled. This function is effective when disabling the trigger signal to a specific camera in the environment where multiple cameras are connected by the same trigger signal and when preventing false operations caused by noise contamination to the trigger signal line (due to the installed environment).

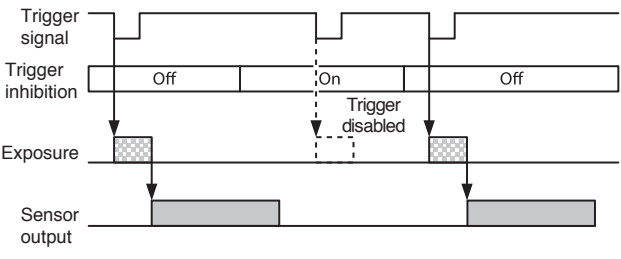

## Trigger Delay

The camera can delay the trigger signal.

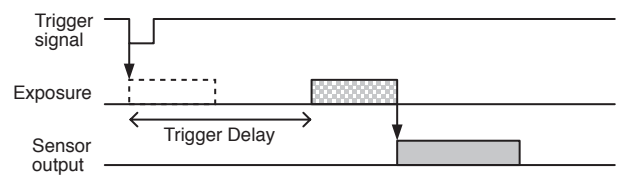

## Trigger Range Limit

Only signals in the set trigger width can be accepted as the trigger signal. This functions as a noise filter, which removes chattering or disturbance noise in the trigger signal line. When the trigger signal is input, exposure is started with the time lag of the trigger range setting values. Image will not be output, when trigger signal width is out of set range.

### Trigger range operation example

ExposureTime=300, TriggerAcceptanceRangeLowerLimit=100 in the figure.

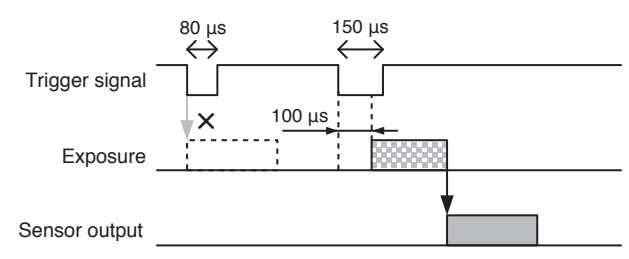

## Overlap trigger

The trigger signals can be accepted during the sensor readout signals are asserted.

If the trigger cycle over the maximum value of the frame rate, images are distorted. Set FastTriggerMode to off.

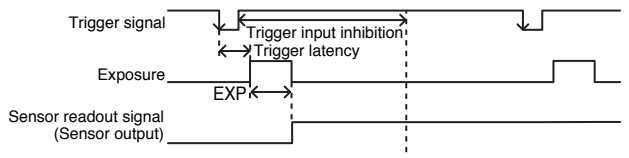

## User Set

Main set values can be saved to the channels 1 to 16 of USERSET.

## Gain

### Manual gain

The manual gain can be finely set in 0.1 dB units or bit levels. Although the settable lower/upper limit values of the gain are slightly different in each camera, the gain parameter value can be set from -1 dB or less to 27 dB or more.

### Auto gain (AGC)

By setting AUTOGAIN, the gain is automatically adjusted according to the image pickup environment.

AGC works so that the average level in a detection frame may reach AGC-LEVEL. The AGC detection frame is set to the central region by default. The detection frame can be displayed or the detection area changed.

## Partial Scan

The partial scan function outputs a user-defined region (Area Of Interest) within the overall image area. The cut-out region for partial scan is defined by Offset X and Offset Y (which indicate the start point for cutting), and Width and Height (which indicate the area). Contiguous blocks of minimum areas can be selected to define regions. However, the defined region must be a square or right rectangle. T- and L-shaped regions are invalid.

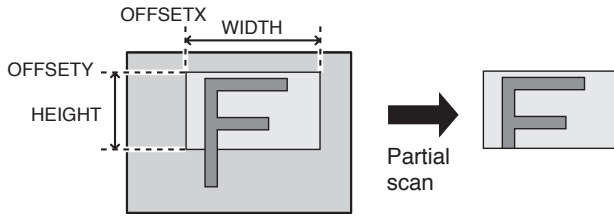

### Note

Be aware that the frame rate increases for vertical cut-outs, while the frame rate remains unchanged for horizontal cut-outs.

## Frame Rate Control

### Auto frame rate

The reading cycle is set to allow the frame rate to be the maximum value automatically according to the current shutter setting and the partial scan setting in the free-run operation (Shutter has priority). The next exposure is performed while outputting a video and the next video output is started immediately after finishing all video outputs. The frame rate is lowered when setting the shutter time longer than the video output time.

### Specifying frame rate

The frame rate of the video output can be specified in the free-run operation. The value of the frame rate [fps] should be entered. The frame rate faster than the fastest frame rate cannot be set.

## Look-Up Table (LUT)

The camera's look-up table consists of 4,096 values, with 12-bit input and output. The look-up table allows setting an arbitrary gamma curve or binarization. Also, a gamma curve coefficient can be specified for the standard black level. For levels below the standard black level, set the gamma value to 1 to prevent burnt-out highlights in the black level.

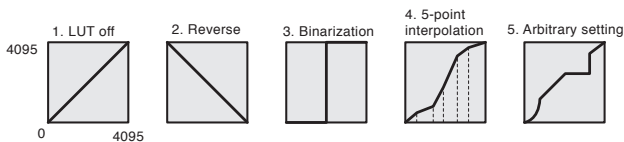

## White Balance

The white balance can be automatically adjusted when the BalanceWhiteAuto command is executed. The detection area is set to the screen center by default. The detection area can also be displayed on the screen. The detection frame can be changed arbitrarily (DetectAreaWBAuto). For manual correction, the GainDigital should be changed.

## GPIO

### GPI

The signal level which is input in the 2nd and 3rd DC IN connector can be detected. After selecting a connector by LineSelector register, the signal level is acquired from LineStatus register.

### GPO

Various signals can be output from the 3rd and 4th DC IN connector. After selecting a connector by LineSelector register and setting LineMode to Output, LineSource is set. The output polarity is set by LineInverter register.

Register	Parameter	Setting
LineSelector	Line 1 (0)	DC IN connector 2nd pin
	Line 2 (1)	DC IN connector 3rd pin
	Line 3 (2)	DC IN connector 4th pin
LineMode	Input (0)	Set to output
	Output (1)	Input setting
LineInverter	Off (0)	Without output inversion
	On (1)	With output inversion
LineStatus		Input signal level
LineSource	TriggerThrough (0)	Trigger through signal
	ExposureActive (2)	Exposure signal
	StrobeActive (3)	Strobe control signal
	SensorReadout (4)	Sensor readout signal
	UserOutput 1 (5)	User definition 1
	UserOutput 2 (6)	User definition 2
	UserOutput 3 (7)	User definition 3
	SignalTrue (8)	Level H
	SignalFalse (9)	Level L
	PWM (10)	Pulse generation signal

Setting example:

The strobe control signal is output to GPO2 (DC IN connector 3rd pin) by Hi active setting.

```
LineSelector = 1
LineMode = 1
LineInverter = 0
LineSource = 3
```

Specifications

	XCU-CG160	XCU-CG160C
<b>Basic specifications</b>		
Image type	B/W	Color
Image size	1.6 Mega	
Image sensor	1/2.9-type Global Shutter CMOS Sensor (Pregius)	
Number of effective pixels (H x V)	1,456 x 1,088	
Cell size (H x V)	3.45 μm x 3.45 μm	
Standard output pixels (H x V)	1,440 x 1,080	
Color filter	—	RGB color mosaic filter
Frame rate	100 fps (8bit ,Mono/Raw)	
Minimum illumination	0.5 lx (Iris: F1.4, Gain: +18 dB, Shutter: 1/30 s)	12 lx (Iris: F1.4, Gain: +18 dB, Shutter: 1/30 s)
Sensitivity	F5.6 (400 lx, Gain: 0 dB, Shutter: 1/30 s)	F5.6 (2000 lx, Gain: 0 dB, Shutter: 1/30 s)
SNR	More than 50 dB (Lens close, Gain: 0 dB, 8 bits)	
Gain	Auto, Manual : 0 dB to 18 dB	
Shutter speed	Auto, Manual : 60 to 1/100,000 s	
White balance	—	Manual, One push, Auto
<b>Camera Features</b>		
Readout modes	Normal, Binning (1x1, 2x1, 2x2), Partial scan (Multi ROI)	Normal, Partial scan (Multi ROI)
Readout features	LUT (Binarization, Gamma (arbitrary setting)), Test pattern	
Synchronization	Hardware trigger, Software trigger	
Trigger modes	OFF (Free run), On (trigger edge detection, trigger width detection), Burst trigger	
User Set/Memory channel	16 channels	
User memory	64 bytes x 16 ch	
Partial scan	W (Pixel)	16 to 1,456
	H (Line)	16 to 1,088
GPO	EXPOSURE/Strobe/Sensor readout/Trigger through/Pulse generation signal/User definition 1, 2, 3 (Selectable)	
Other features	Area gain, Shading correction, Defect correction, Temperature readout, LUT, 3 x 3 filter	
<b>Interface</b>		
Video data output	digital Mono 8, 12 bit (default setting 8 bit)	digital Raw 8, 12 bit (default setting Raw 8 bit) RGB, YCbCr422, YCbCr8
Digital interface	USB3.0 (only super speed)	
Camera specification	USB3 Vision® Ver.1.0.1	
Digital I/O	ISO IN(x1), ISO OUT(x1), TTL IN/OUT (x1,selectable)	
<b>General</b>		
Lens mount	C-mount	
Flange focal length	17.526 mm	
Power requirements	DC +12 V (10.5 V to 15.0 V), USB bus power (DC +5V ±5%)	
Power consumption	DC +12 V 3.5W	
	USB bus power 3.0W	
Operating temperature	-5°C to +45°C	
Performance guarantee temperature	0°C to 40°C	
Storage temperature	-30°C to +60°C	
Operating humidity	20% to 80% (no condensation)	
Storage humidity	20% to 80% (no condensation)	
Vibration resistance	10 G (20 Hz to 200 Hz, 20 minutes for each direction-x, y, z)	
Shock resistance	70 G	
Dimensions (W x H x D)	29 x 29 x 30 mm (excluding protrusions)	
Mass	Approx. 50 g	
MTBF	67,447 hours (Approx. 7.7 yeares)	
Regulations	UL60950-1, FCC Class A, CSA C22.2-No.60950-1, IC Class A Digital Device, CE : EN61326-1 (Class A), AS EMC: EN61326-1, VCCI Class A, KCC, CU-TR EAC : EN61326-1	
Supplied accessories	Lens mount cap (1), Operating Instructions (1)	