

xiD

- scientific grade CCD sensors
- fastest in class through 4 tap readout
- ultra-low noise with passive sensor cooling

ximea



USB3.0 CCD camera series

[sci-di:]
or [ksi-di:]

The **xiD** series is based on the most advanced Sony CCD sensor (available till 2025). As CCDs, they boast high sensitivity and 14 bit dynamic range. The cameras have excellent passive cooling properties, great performance and allow USB bus powering. The board-level versions include a system integration guide for designing an optimal heatsink and enclosure. Due to the implementation of a 4 tap readout, this series supports the maximum frame rates that the sensors deliver.

Quick facts

- Sony ICX with “EXview HAD CCD II” pixel technology
- Passive cooling of sensor
- Improved light efficiency for NIR spectrum
- Global shutter with interline transfer
- 1, 2 or 4 tap readout with 14 bit ADC
- Lowest power consumption

Housed cameras

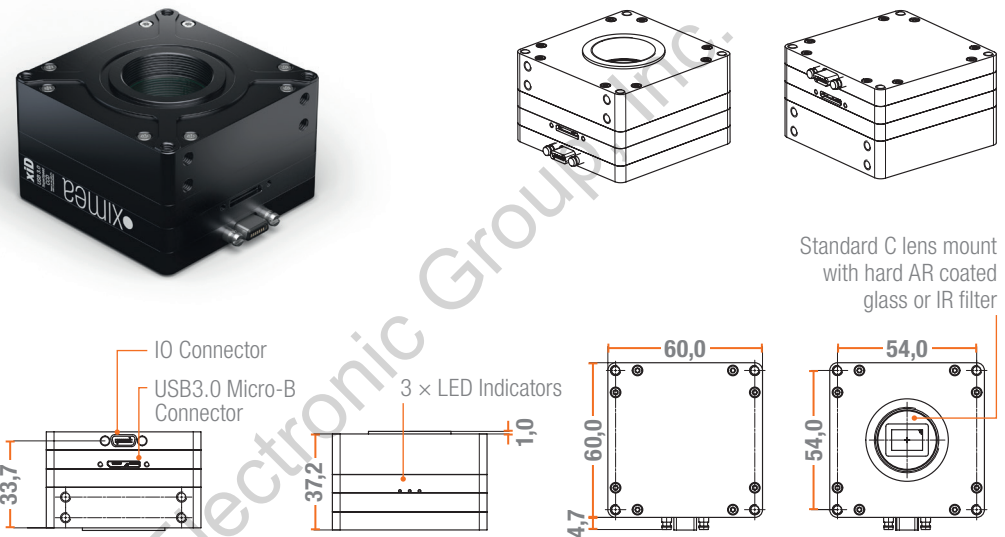

Board-level cameras¹

Option for optimal system integration

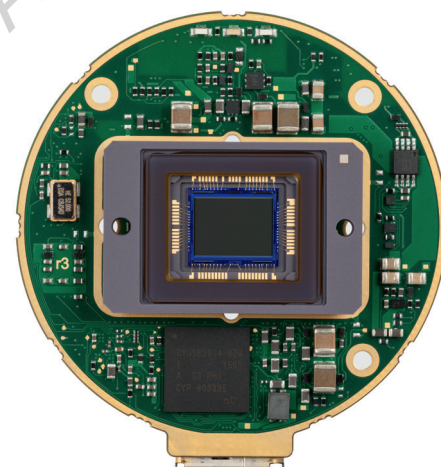

Standard Micro-B (-BRD)

- Board-level version of standard housed camera with Micro-B connector, parallel to board surface

Note 1: Board level cameras are OEM items subject to minimum order quantities

The information provided herein is subject to change without notice

Supported vision libraries

Compatible with more than 30 popular machine vision libraries

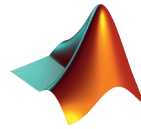

XIMEA strives to create and maintain compatibility and interfaces for the most common and advanced vision image-processing libraries and applications. Major support is available for **MVTec Halcon**, **National Instruments LabVIEW**, **MathWorks MATLAB** and **OpenCV**. Please check our XIMEA website for an up-to-date list of other supported libraries and software packages.

Compatibility

Supported operating systems

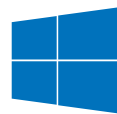

Windows



Linux



OS X

Standards



About us

**Big
about
small**

Why would we make that claim?

We say that because we just love to make cameras small, and excel at this task. Nobody makes the same thing any smaller. Is that a good thing? We certainly think so, especially when our products exceed customer satisfaction and specification. With small, comes low mass, another massive advantage for all our customers. High density means we have to take extraordinary care regarding power consumption and heat dissipation. But... that does not mean we allow any compromises. Everything we include in our products is of industry standard or better. Thanks to the full metal body, our cameras – literally and figuratively – are extremely cool, and because of our love for speed they are also fast. This design paradigm optimizes for the most ideal specifications for the broadest set of customers.

Our passion about small things also extends to the company itself.

We take conscious action to stay small and agile as a company. Consequentially our people must be extraordinarily talented to ensure efficient processes and cover all bases. We have well defined outsourcing interfaces with close interactions internally and externally with management as a part of the team. Being small keeps everyone focused and aware of what is going on, which quickly translates into customer satisfaction.

Thanks for your time.

All trademarks are the property of their respective holders, used with permission. All other rights reserved.

Sensors and models

Model		Sensor	Resolution	Pixel size [μm]	ADC [bits]	DR [dB] ¹⁾	FWC [e-]	Sensor size/diagonal [mm]	Power [W]	FPS ²⁾
MD028MU-SY	b/w	SONY ICX674	1934 × 1456 2.8 Mpix	4.54	8, 10, 12, 14	68.6	20000	8.8 × 6.6 11	3.6	56.9
MD028CU-SY	color									
MD061MU-SY	b/w	SONY ICX694	2754 × 2204 6.1 Mpix	4.54	8, 10, 12, 14	68.7	19500	12.5 × 10.0 16	3.9	28.4
MD061CU-SY	color									
MD091MU-SY	b/w	SONY ICX814	3384 × 2708 9.1 Mpix	3.69	8, 10, 12, 14	64.7	12000	12.5 × 10.0 16	4.2	19.5
MD091CU-SY	color									
MD120MU-SY	b/w	SONY ICX834	4242 × 2830 12.0 Mpix	3.1	8, 10, 12, 14	63.5	10000	13.2 × 8.8 15.8	4.5	15.3
MD120CU-SY	color									

Note 1: 26 MHz readout frequency

Note 2: 52 MHz, 4 taps, RAW 14 bits

Aegis Electronic Group, Inc.

Contact

Worldwide
XIMEA GmbH