



**For FA/Machine Vision  
Fixed Focal**

**CF50HA-1**

1	2/3	1/2	1/3	1/4
---	-----	-----	-----	-----

**NEW**



- High-resolution design, providing support for up to 1.5 megapixel camera resolution.
- Wide-aperture (F1.8) design achieves clear images under low light intensity, despite the long focal distance.
- Low-distortion design achieving accurate image input.
- Robust enclosure resistant to vibrations and shocks. Equipped with locking knobs for the iris and the focus.

**FIXED**  
Fixed Focal

**1.5 Mega**  
For Megapixel Camera

**MANUAL**  
Manual Iris

**C-mt**  
C Mount

**METAL**  
Metal Mount

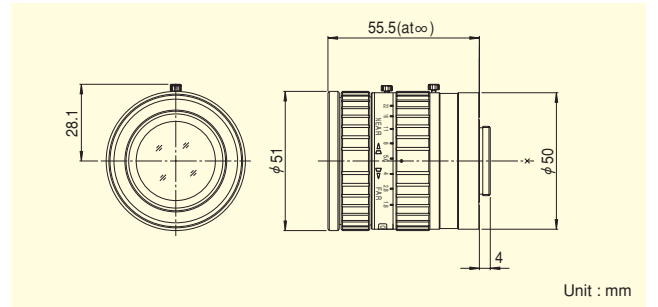

Unit : mm

Focal Length (mm)		50
Iris Range		F1.8 ~ F22
Operation	Focus	Manual
	Iris	Manual
Angle Of View (H×V)	1"	14°35' × 10°58'
	2/3"	10°03' × 7°33'
	1/2"	7°19' × 5°30'
Focusing Range (From Front Of The Lens) (m)		∞ ~ 0.4 *1
Object Dimensions at M.O.D. (H×V) (mm)	1"	101 × 76
	2/3"	70 × 52
	1/2"	51 × 38
Back Focal Distance (in air) (mm)		17.81
Exit Pupil Position (From Image Plane) (mm)		-49
Filter Thread (mm)		M49 × 0.75
Mount		C
Mass (g)		235

**Remarks**

- With Metal Mount
- With Locking Knob for Iris and Focus

\*1 Using an extension tube longer than 5mm will increase the M.O.D. to 0.3m.

FIXED FOCAL LENGTH LENSES



**For FA/Machine Vision  
Fixed Focal**

**CF75HA-1**

1	2/3	1/2	1/3	1/4
---	-----	-----	-----	-----

**NEW**



- High-resolution design, providing support for up to 1.5 megapixel camera resolution.
- Wide-aperture (F1.8) design achieves clear images under low light intensity, despite the long focal distance.
- Low-distortion design achieving accurate image input.
- Robust enclosure resistant to vibrations and shocks. Equipped with locking knobs for the iris and the focus.

**FIXED**  
Fixed Focal

**1.5 Mega**  
For Megapixel Camera

**MANUAL**  
Manual Iris

**C-mt**  
C Mount

**METAL**  
Metal Mount

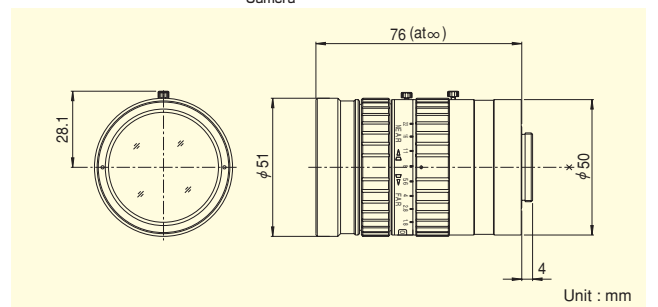

Unit : mm

Focal Length (mm)		75
Iris Range		F1.8 ~ F22
Operation	Focus	Manual
	Iris	Manual
Angle Of View (H×V)	1"	9°45' × 7°19'
	2/3"	6°43' × 5°02'
	1/2"	4°53' × 3°40'
Focusing Range (From Front Of The Lens) (m)		∞ ~ 0.9 *2
Object Dimensions at M.O.D. (H×V) (mm)	1"	147 × 111
	2/3"	101 × 76
	1/2"	74 × 55
Back Focal Distance (in air) (mm)		24.43
Exit Pupil Position (From Image Plane) (mm)		-52
Filter Thread (mm)		M49 × 0.75
Mount		C
Mass (g)		295

**Remarks**

- With Metal Mount
- With Locking Knob for Iris and Focus

\*2 Using an extension tube longer than 5mm will increase the M.O.D. to 0.5m.