

H6Z0812M

6X 8mm - 48mm F1.2
for 1/2 type Cameras, Motorized Zoom
C-Mount

Model No.	H6Z0812M		Effective	Front	Ø39.2mm			
Focal Length	8mm - 48mm		Lens Aperture	Rear	Ø16.6mm			
Max. Aperture Ratio	1:1.2		Back Focal Length	11.4mm				
Max. Image Format	6.4mm x 4.8mm(Ø8mm)		Flange Back Length	17.526mm				
Operation Range	Iris	F1.2 - F16C		Mount	C-Mount			
	Focus	1.2m - Inf.		Filter Size	M49 P=0.75mm			
	Zoom	8mm - 48mm		Tripod Screw	1/4 - 20UNC			
Control	Iris	Motorized		Dimensions	W66mm x H73.5mm x D97mm			
	Focus	Motorized		Weight	400g			
	Zoom	Motorized						
Object Dimension at M.O.D.	8mm	98.4cm x 72.2cm						
	48mm	16.8cm x 12.8cm						
Angle of View	D	1/2 type	55.8° - 9.9°	1/3 type	41.8° - 7.5°	1/4 type	31.4° - 5.6°	
	H		44.6° - 8.0°				33.5° - 6.1°	25.2° - 4.6°
	V		33.5° - 6.1°				25.2° - 4.6°	18.9° - 3.4°
		Iris		Focus		Zoom		
Supply Voltage	DC8V			DC8V	DC8V			
Current	20mA or less			30mA or less	30mA or less			
Response Time	Approx. 2.5 sec.			Approx. 4.5 sec.	Approx. 4 sec.			
Preset Potentiometer	—				—			
Operating Temperature	-10°C - +50°C							

1/2
type

C

M.O.D. : Minimum Object Distance

Dimensions

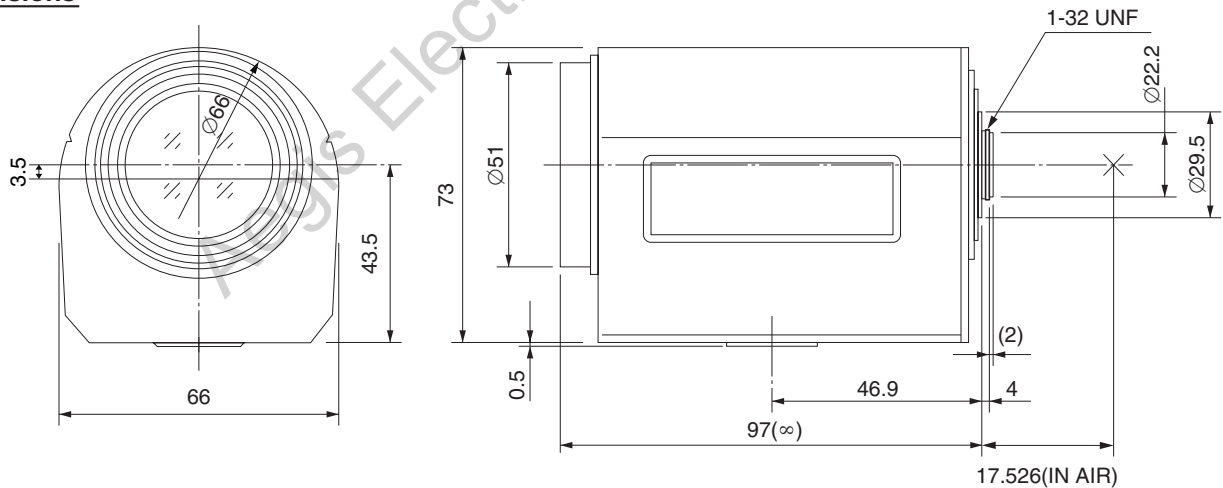

Wiring Diagram

