

# T10Z5712AMS-CS

**10X 5.7mm - 57mm F1.2**  
**for 1/3 type Cameras, Motorized Zoom**  
**CS-Mount**

with Video Auto Iris

1/3  
type

Model No.	T10Z5712AMS-CS		Effective	Front	Ø45.0mm
Focal Length	5.7mm - 57mm		Lens Aperture	Rear	Ø8.6mm
Max. Aperture Ratio	1:1.2		Back Focal Length	8.5mm	
Max. Image Format	4.8mm x 3.6mm(Ø6mm)		Flange Back Length	12.5mm	
Operation Range	Iris	F1.2 - F560C	Mount	CS-Mount	
	Focus	1.8m - Inf.	Filter Size	M49 P=0.75mm	
	Zoom	5.7mm -57mm	Tripod Screw	1/4 - 20UNC	
Control	Iris	Video Auto Iris	Dimensions	W68.5mm x H76.3mm x D88mm	
	Focus	Motorized	Weight	470g	
	Zoom	Motorized			
Object Dimension at M.O.D.	5.7mm	147.6cm x 110.8cm			
	57mm	15.1cm x11.6cm			
Angle of View	D	1/3 type	54.2° - 5.9°	1/4 type	42.0° - 4.5°
	H		44.6° - 4.8°		34.2° - 3.7°
	V		34.2° - 3.7°		25.9° - 2.7°
	Iris	Focus	Zoom		
Supply Voltage	DC8.5V - DC16V		DC8V	DC8V	
Current	40mA or less		20mA or less	20mA or less	
Response Time	Approx. 2 sec.		Approx. 3 sec.	Approx. 3.5 sec.	
Preset Potentiometer	—			—	
Light Weighting Method	Adjustable between Average - Peak (to be Set at Average at Factory)				
Remote Control	Level Remote (Option)				
Input Signal	Video Signal (V. or V.S.)				
Iris Accuracy	±15% at Video Signal Level				
Sensitivity Adjustment	0.5V(p-p) - 1.0V(p-p) (Video Signal)				
Input Impedance	High Impedance				
Operating Temperature	-10°C - +50°C				

CS

## Dimensions

M.O.D. : Minimum Object Distance

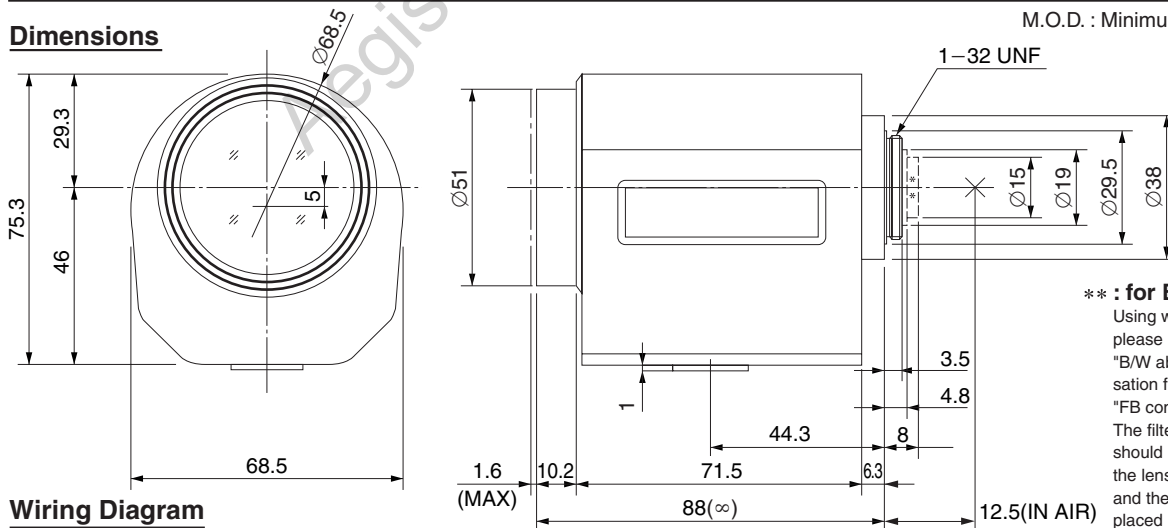

## Wiring Diagram

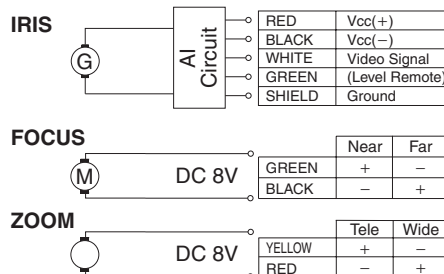

**\*\* : for B/W camera**  
 Using with a B/W camera, please use the attached "B/W aberration compensation filter" and "FB compensation spacer". The filter(M20 P=0.5mm) should be screwed onto the lens from rear side and the spacer should be placed between lens and camera.

