

# TEC-M05110MP

**Magnification 0.5X, WD110mm**  
**for 2/3 type Cameras, 2 Megapixel Telecentric Lens**  
**C-Mount, Straight type**

Model No.	TEC-M05110MP		NA	0.026
Magnification	0.5X	TV Distortion	2/3 type	-0.009%
Working Distance	111.8mm	Back Focal Length	17.0mm	
Effective F Number	9.4	Flange Back Length	17.526mm	
Max. Image Format	φ 11mm	Mount	C-Mount	
Control	Iris	-	Filter Size	-
	Focus	-		
Field of View	17.6mm(H) x 13.2mm(V) 2/3"		Dimensions	φ 35mm x 131.2mm
Resolving Power *1	12.7μm	Weight	128g	
Depth of Field *2	3.03mm	Operating Temperature	-10°C - +50°C	

\*1:Theoretical resolution calculated with a wavelength of 550nm  
 \*2:Value calculated with a permissible circle of confusion of 40 μ m

**Dimensions**

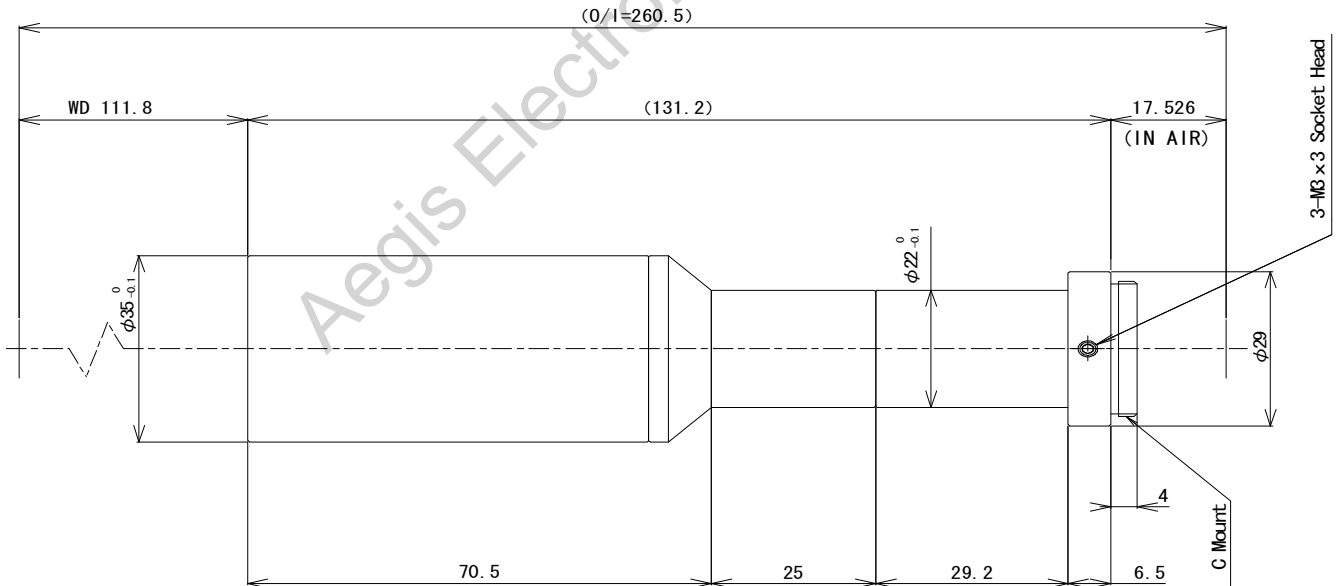

**Field of View at Sensor Size**

Format	Field of View(HxV)
2/3"	17.6 x 13.2mm
1/1.8"	14.3 x 10.6mm
1/2"	12.8 x 9.6mm
1/3"	9.6 x 7.2mm

For more information please contact Aegis Electronic Group, Inc. \*(888)687-6877 \*aegis-g2@aegiselect.com \*http://www.aegiselect.com