

M1614-SW

f=16mm F1.4

for 2/3 type SWIR (800nm~1700nm) Cameras

C-Mount

Model No.	M1614-SW		Effective	Front	φ 18.5mm	
Focal Length	16mm		Lens Aperture	Rear	φ 13.2mm	
Max. Aperture Ratio	1:1.4		Distortion	2/3type	-0.5% (y=5.5)	
Max. Image Circle	φ 12.3mm			1/2type	-0.5% (y=4.0)	
Operation Range	Iris	F1.4- F16C	Back Focal Length		13.3mm	
	Focus	0.3m - Inf.	Flange Back Length		17.526mm	
Control	Iris	Manual	Mount		C-Mount	
	Focus	Manual	Filter Size		M30.5 P=0.5mm	
Object Dimension at M.O.D	2/3 type	17.0cm x 12.7cm	Dimensions		φ 33.5mm x 28.2mm	
	1/2 type	12.3cm x 9.2cm	Weight		60g	
Angle of View	D	2/3 type	37.7°	1/2 type	27.9°	
	H	H8.80mm x V6.60mm	30.6°	H6.40mm x V4.80mm	22.5°	
	V		23.2°		16.9°	
Angle of View (InGaAs Detector)	D	640 x 512	41.7°	320 x 256	35.3°	320 x 256
	H	(Pixel Pitch : 15 μ m)	33.2°	(Pixel Pitch : 25 μ m)	27.9°	(Pixel Pitch : 20 μ m)
	V	H9.60mm x V7.68mm	26.8°	8.00mm x V6.40mm	22.5°	H6.40mm x V5.12mm
Operating Temperature			-10°C - +50°C			

M.O.D : Minimum Object Distance

Dimensions

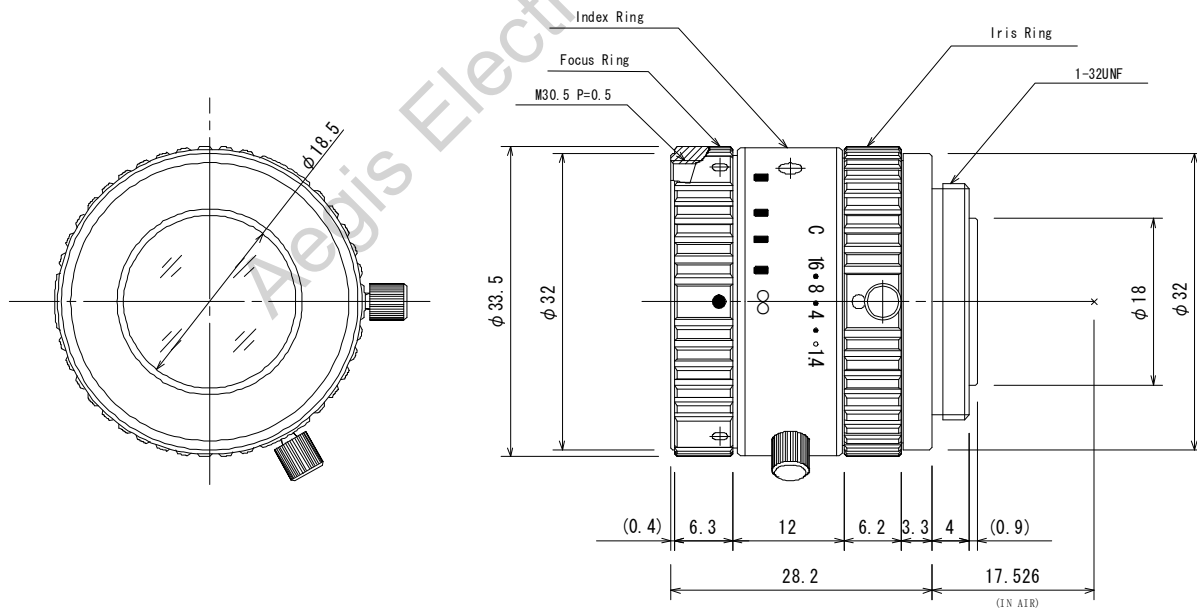

For more information please call Aegis Electronic Group, Inc. *(888)687-6877 *aegis-g2@aegiselect.com *http://www.aegiselect.com