

PL-B954F & PL-B955F FireWire
 PL-B954G & PL-B955G Gigabit Ethernet
 PL-B954U & PL-B955U USB 2.0

1.4 MP (1392 x 1040)
 Monochrome & Color Cameras
 10 fps Free Running - 10 fps Triggered

General Description

These high performance 1.4MP (1392 x 1040) resolution cameras are designed for a broad range of industrial imaging applications. The PL-B955 monochrome camera and the PL-B954 color camera provide 10 frames per second in either 8-bit or 12-bit output modes. The cameras are based on the Sony ICX205 progressive scan CCD sensor with a 1/2" optical format and a 4.65 um pixel pitch. This ILT CCD features high-speed electronic shuttering, low image lag and low smear making the cameras ideally suited to capturing crisp images of objects in motion, common to many machine vision applications. High sensitivity, low dark current and anti-blooming further enhance image quality. In-camera Flat Field Correction (FFC) corrects for non-uniform illumination and optics in addition to the sensor's dark noise variations, which ensures good image quality over a wide range of operating conditions.

You have the choice of a FireWire, Gigabit Ethernet or USB 2.0 interface, all of which eliminate the need for a frame grabber. PixelINK's industry leading Software Developer's Kit (SDK) uses a common API for all cameras regardless of the chosen interface. Software developed for one camera is easily transferred to other PixelINK models without the need to recompile code resulting in lower system costs and simplified integration.

With the SDK, PixelINK supplies a full Application Programming Interface (API) and extensive source code examples for fast and easy application development. The API functionality includes several triggering and GPIO modes for quick integration with strobed illumination and motion controllers. All of these features, plus many more, are included in PixelINK's free demonstration application, PixelINK Capture OEM, available for download at www.PixelINK.com The SDK also includes wrappers for National Instruments LabVIEW software. For those requiring additional software flexibility, Direct Show, DCAM (FireWire only) and TWAIN are also supported.

Typical Applications

The PL-B954 & 955 cameras are suitable for a broad range of applications such as automated inspection, PCB and semiconductor inspection, container inspection, food and beverage inspection, and manufacturing quality control.

FireWire, Gigabit Ethernet & USB 2.0 Interfaces

We appreciate that OEMs and System Integrators are constantly looking for ways to reduce system costs and complexity. PixelINK has answered this call by offering three widely accepted interfaces all of which eliminate the need to purchase & integrate frame grabber boards and expensive custom cables.



IEEE 1394A – FireWire has proven itself as a reliable and robust interface over the past decade in machine vision applications. The deterministic communication provided by FireWire allows for precise timing in machine vision applications. PixelINK's FireWire cameras support the IIDC 1.31 specification making them compatible with a wide range of 3rd party DCAM software applications.

Gigabit Ethernet – 1,000 Mbit data rates, 100M cable lengths and networked connectivity have made the Gigabit Ethernet interface for machine vision, appropriately named GigEVision, the fastest growing interface over the past years. Transmission is provided via standard CAT5E or CAT6 cables.

USB 2.0 – Universality of this interface on host PCs is a major benefit for applications in the consumer end-user markets. Plug-and-play operation and low cost cabling makes USB 2.0 the leading user-friendly interface.

Customization

The products listed here are standard offerings. PixelINK also provides an extensive list of customized cameras to OEM customers around the world. If you can't find what you are looking for in the standard products, call us. We may already have what you need. If not, we can certainly design and build it for you.

FEATURES

- Common API for all cameras
- High Speed Global Shutter
- Low Noise, High Responsivity CCD Sensor
- In-camera Flat Field Correction (FFC) & Defective Pixel Correction

BENEFITS

- Use existing code without recompiling. Saves development time and money.
- Low smear image of fast moving objects
- Suitable for applications with low levels of illumination or short exposure time
- Provides superior image quality by correcting for non-uniform illumination, lens shading, and sensor Fixed Pattern Noise (FPN)

SENSOR

Sensor	Sony ICX205
Type	Inter Line Transfer (ILT)
Resolution	1392(H) x 1040(V) Color & Mono
Pixel Pitch	4.65 μm x 4.65 μm
Active Area	7.60 mm x 6.20 mm - 7.96 mm diagonal
Max Datarate	20 MHz

COMPUTER & OPERATING SYSTEM

Processor	2.0 GHz or better
Memory	512 MB min. 1 GB recommended
Operating System	Windows 2000, XP and Vista (32bit)
Hard Drive Space	75 MB

POWER REQUIREMENTS

Voltage Req.	FireWire/GigE 8-32 V DC - USB 5 V DC
Power Req. PL-B954	FireWire 4.0 W, USB 3.6 W, GigE 5.0 W
Power Req. PL-B955	FireWire 4.0 W, USB 3.6 W, GigE 5.0 W

ENVIRONMENTAL & REGULATORY

Compliance	FCC Class B, CE & RoHS
Shock & Vibration	300 G & 20 G (10Hz - 2KHz)
Operating Temp.	0°C to 50°C (non-condensing)
Storage Temp.	-45°C to 85°C

SOFTWARE

PixeliNK Capture OEM	Free Download (www.pixelink.com)
DirectShow (exl. GigE)	Bundled with PixeliNK Capture OEM
TWAIN	Bundled with PixeliNK Capture OEM
SDK	API, sample code and LabVIEW wrappers
DCAM 1394 Compliance	IIDC version 1.31

CAMERA CONTROLS & FEATURES

*Auto & Manual White Balance, *Color Temperature, Gain, Gamma, *Saturation, Histogram, Binning, Averaging, *Resampling, Image Flip & Rotate, Programmable LUT, In-Camera Defective Pixel & Color Correction, Callbacks (Image Filters), FFC (Gain & Offset). * **Color Models Only**

PIXELINK CAPTURE OEM SOFTWARE

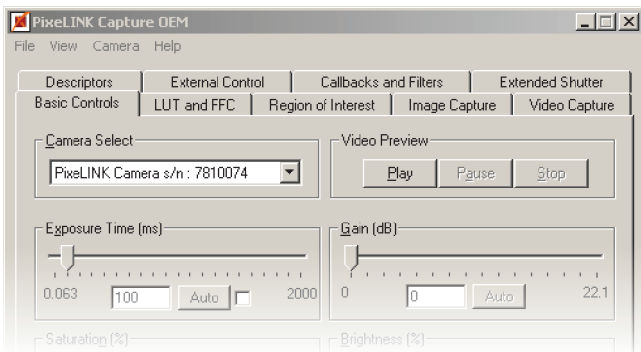

PixeliNK Capture OEM is a user-friendly camera control application offering users full control of the camera's features and settings. For your free copy of Capture OEM, please visit the PixelINK web site at www.PixelINK.com

PERFORMANCE & SPECIFICATIONS *

Responsivity	Mono 10.7 - 43.4 DN/(nJ/cm ²) Color 10.3 - 42.1 DN/(nJ/cm ²)
FPN	<0.3 %
PRNU	<2.5 %
Read Noise	Mono 3.68 DN - Color 3.29 DN
Dynamic Range	Mono 60.9 dB - Color 61.9 dB
Bit Depth	8 & 12-bit
Color Data Formats	Bayer 8, Bayer 16 and YUV422
Mono Data Formats	Raw, Mono 8 and Mono 16
Exposure Range	100 μs to 10 seconds free running 100 μs to 10 seconds triggered
Gain	0 dB to 24.57 dB in 29 increments

*Camera Settings: 40ms integration time, 0dB gain, FFC on, 12-bit mode

MECHANICALS

Dimensions	118.75 x 50 x 41 mm (straight) 110 x 50 x 41 mm (right angle)
Weight	238 g
Mounting	4 M3 threaded holes in front plate & 4 M3 threaded holes in camera case
Tripod Mount	1/4" - 20 mount (optional)
Status LED	Amber - Start-up, Green - Idle or streaming Red - Warning or failed status
Lens Mount	C & CS-Mount, 1/3" optical format

INTERFACES

Interface / Date rate /	IEEE 1394A (2) / 400 Mbit / 6-pin
Connector	GigE / 1000 Mbit / RJ-45 USB 2.0 / 480 Mbit / Type B
Trigger Connector	9-pin Micro D
Trigger Modes	Free running, software, hardware
Trigger Input	Optically isolated 5-12V DC @ 4-11 mA
GPO/Strobe	2 Optically Isolated - Maximum 40V DC differential. Maximum 15 mA

For more information, visit: <http://www.pixelink.com/help>

PIN OUTPUT DESCRIPTION

Pin Pin Name & Function

- POWER cable power, FireWire/GigE 8-32 V DC - USB 5 V DC
- Gp2+ Positive terminal of GPO 2
- Gp2- Negative terminal of GPO 2
- Gp1+ Positive terminal of GPO 1
- Gp1- Negative terminal of GPO 1
- TRIGGER + Positive terminal of trigger input
- TRIGGER - Negative terminal of trigger input
- (no connection)
- GROUND Logic and chassis ground

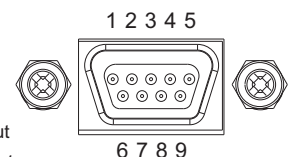

STRAIGHT & RIGHT ANGLED MECHANICAL DIMENSIONS

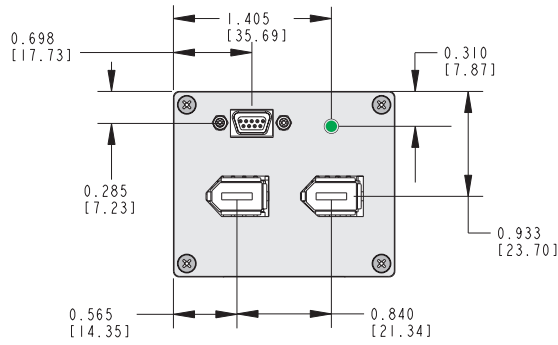

Back Panel FireWire

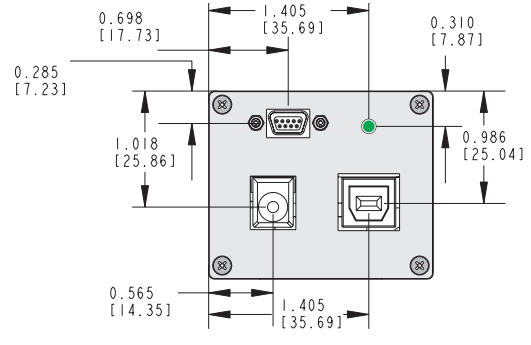

Back Panel USB 2.0

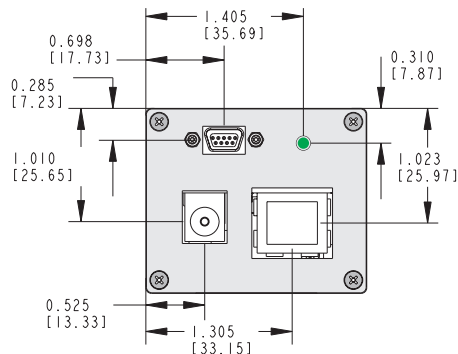

Back Panel GigE

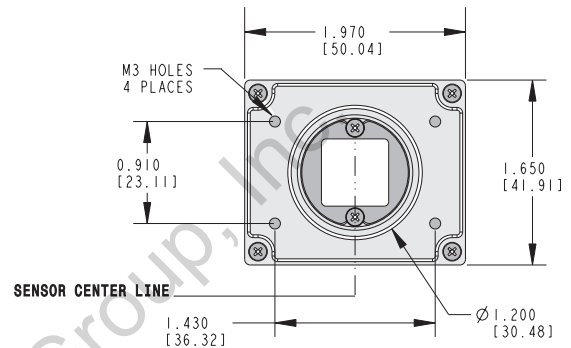

Front Panel

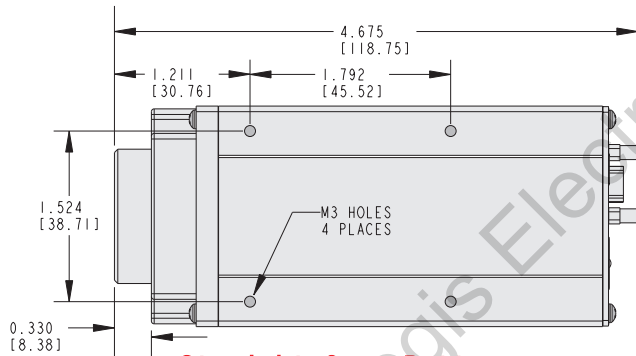

Straight Case Bottom

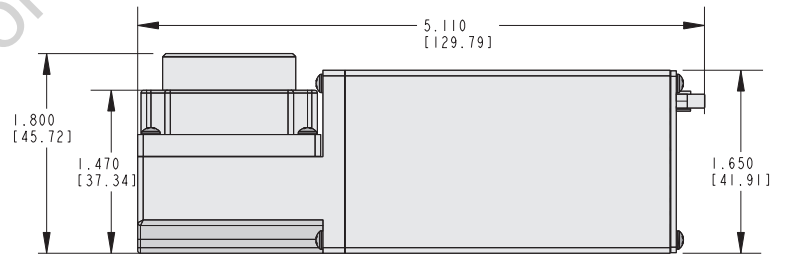

Right Angle Case

RESPONSIVITY CURVE - MONO

0dB Gain, 10bit Data

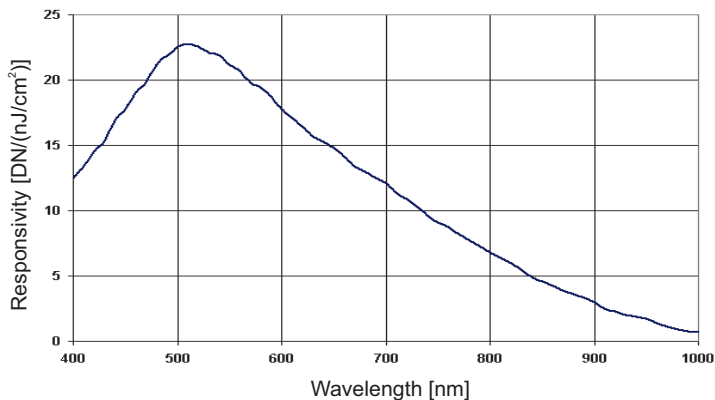

RESPONSIVITY CURVE - COLOR

0dB Gain, Channel Gains at Unity, 10bit Data

